

ZEITRAUM

GE

EN

UM

—

GS

FE

CE

ZEITRAUM

RAUM FÜR *DINGE*

DINGE FÜRS LEBEN

LEBEN IM RAUM

SPACE FOR THINGS

THINGS FOR LIFE

LIVING *SPACE*

K

KIN ist eine Familie unterschiedlich großer Stauraumformate, die Platz für die Dinge des Lebens schaffen, unabhängig von ihrer konkreten Anwendung.

KIN is a family of cabinets with each member in a specific format. Regardless of their field of application they create room for the things that matter.

I

N

—

DESIGN BY MATHIAS HAHN
2016

WIR SIND EINE FAMILIE

Die Proportion jeden Formats bietet genau die Menge an Raum, um in möglichst vielen Wohnsituationen eingesetzt werden zu können. Ändert sich das Wohnumfeld oder die Bedürfnisse, erlaubt KIN Flexibilität.

Einzelne Elemente können im Laufe der Zeit unterschiedlichste Aufgaben übernehmen und in verschiedenen Bereichen der Wohn- und Arbeitswelt ihren Platz finden.

Die Familienmitglieder von KIN haben ihren eigenen individuellen Charakter als Solitär und ergänzen sich dennoch bestmöglich in der freien Gruppierung.



KIN TALL

Aufgrund seiner Größe ist KIN TALL raumfassend aber doch zurückhaltend. KIN TALL ist ausschließlich mit schlichtem Sockel erhältlich.

KIN TALL remains unobtrusive despite its substantial proportions. KIN TALL is available only with a simple base.



KIN BIG

Als eigenständiges Einzelmöbel hält KIN BIG auch für unkonventionelle Anwendungen Lösungen bereit und bietet effiziente Verstaumöglichkeiten.

As a stand-alone piece of furniture, KIN BIG offers efficient storage solutions for a wide range of tasks.



KIN LONG

Mit einer Fülle von Kombinationsmöglichkeiten ist KIN LONG das vielseitigste Element in der Familie und erlaubt viele eigenständige Konfigurationen.

With its huge range of possible combinations, KIN LONG is the most versatile in our range of cabinets and allows for a diversity of configurations.

WE ARE *FAMILY*

The cabinets of various proportions offer just the right amount of space for every situation.

KIN provides flexibility, adapting to changes in your life.

With time individual units can take on different functions both at home and at work.

Each member of the KIN family has its own character and yet harmonises perfectly with its siblings.



Ob als freistehendes Einzelmöbel, in Reihe gestellt oder gestapelt, KIN LONG paßt sich optimal unterschiedlichen Lebenssituationen an.

Whether as a stand-alone, stack or a row, KIN LONG adapts perfectly to suit every situation.

Durch seine Vielseitigkeit bietet KIN LONG die Möglichkeit mitzuwachsen und auch mehrfache Tapetenwechsel zu überdauern.

Through its versatility, KIN LONG can grow with you and your changing needs.

Als Nachtkästchen in der Schubfachversion oder als Beistellmöbel im Wartebereich setzt KIN TINY Akzente im Alltag.

As a nightstand in the version with drawers or as a piece of occasional furniture in a lobby, KIN TINY brings pleasure into everyday life.

KIN TINY

T



SCHRANK

WARDROBE

L



*KIN TALL 1 // Schrank mit Holzsockel, Eiche graphitgrau gebeizt, Massivholz
CARLA // Spiegel, wandmontiert mit Ablage, Eiche, Massivholz mit MORPH STOOL // Hocker
Eiche, Gestell Massivholz, Schale Formholz furniert, Sitzpolster Stoff Nadir 182, Kvadrat
PELLE // Stuhl, Gestell Eiche, Massivholz, frei hängender Sitz aus Kernleder, asphalt (linke Seite)*

***KIN TALL 1 // Wardrobe with plinth in wood, oak stained graphite grey, solid wood
CARLA // Mirror, wall mounted with shelf, oak, solid wood with MORPH STOOL // Stool
oak, frame solid wood, seat veneered plywood, padded seat fabric Nadir 182, Kvadrat
PELLE // Chair, frame oak, solid wood, freely hanging seat made from core leather, asphalt (left page)***



Oben: KIN Hang, Kleiderstange, Eiche, Massivholz
Unten: KIN Flat, Tablar, Eiche, Massivholz

Above: KIN Hang, clothes rail set, oak, solid wood
Below: KIN Flat, tablar, oak, solid wood



Oben: KIN Shelf, Einlegeboden mit Tip-on Beschlag, Eiche, Massivholz
Unten: KIN Drawer, Innenschub, Eiche, Massivholz

Above: KIN Shelf with Tip-on binder, oak, solid wood
Below: KIN Drawer, inset drawer, oak, solid wood



*KIN TALL 1 & 2 // Schrank-Kombination mit Holzsockel, amerikanischer Nussbaum, Massivholz
mit KIN Shelf, Einlegeböden mit Tip-on Beschlag, KIN Hang, Kleiderstange, KIN Drawer, Innenschub
amerikanischer Nussbaum, Massivholz*

***KIN TALL 1 & 2 // Wardrobe combination with plinth in wood, American walnut, solid wood
with KIN Shelf with Tip-on binder, KIN Hang, clothes rail set, KIN Drawer, inset drawer
American walnut, solid wood***



KIN TALL 1 & 2 // Schrank-Kombination mit Holzsockel, amerikanischer Nussbaum, Massivholz
MIUT COMFORT // Boxspringbett, Stoff Hero 931, Kvadrat, FüÙe amerikanischer Nussbaum, Massivholz
DAYDREAM // Tagesdecke, Stoff Revive 1 454, Kvadrat

KIN TALL 1 & 2 // Wardrobe combination with plinth in wood, American walnut, solid wood
MIUT COMFORT // Box spring bed, fabric Hero 931, Kvadrat, feet American walnut, solid wood
DAYDREAM // Coverlet, fabric Revive 1 454, Kvadrat



GRAND MELLOW // Bett, Gestell Eiche, Massivholz
Rückenkissen Leder Jepard schlammgrau, Reinhardt, Lederschnur pastellrauchblau
DAYDREAM // Tagesdecke, Stoff Pause 4 254, Kvadrat und Überwurf, Stoff Topia messing, Rohi
BONDT L // Beistelltisch, Eiche, Massivholz

***GRAND MELLOW* // Bed, frame oak, solid wood
back cushions leather Jepard schlammgrau, Reinhardt, leather strap pastel smoke blue
DAYDREAM // Coverlet, fabric Pause 4 254, Kvadrat and plaid, fabric Topia messing, Rohi
BONDT L // Sidetable, oak, solid wood**



KIN TALL2// Schrank mit Holzsockel
mit KIN Shelf, Einlegeböden mit Tip-on Beschlag, KIN Hang, Kleiderstange, KIN Flat, Tablar
Eiche, Massivholz

KIN TALL2// Wardrobe with plinth in wood
with KIN Shelf with Tip-on binder, KIN Hang, clothes rail set, KIN Flat, tablar
oak, solid wood

KOMMODE



CABINET



KIN BIG // Kommode, Eiche kaltgrau gebeizt, Massivholz
mit KIN Base 3, Gestell Stahl steingrau (RAL 7030) matt pulverbeschichtet, h 50 cm
KIN Shelf, Einlegeboden mit Tip-on Beschlag und KIN Hang, Kleiderstange, Eiche, Massivholz

***KIN BIG* // Cabinet, oak stained cold grey, solid wood**
with KIN Base 3, frame steel stone grey (RAL 7030) matt powder coated, h 50 cm
KIN Shelf with Tip-on binder and KIN Hang, clothes rail set, oak, solid wood

KIN BIG IST VARIABEL IN SEINER ANWENDUNG. SO WIRD ZUM BEISPIEL AUS EINEM *KOMPAKTEN KLEIDERSCHRANK*, WIE ER IN EIN KINDERZIMMER PASSEN KÖNNTE, EIN *GROSSZÜGIGER KÜCHENSCHRANK* ODER ...



KIN BIG ADAPTS TO YOUR NEEDS. FROM BEING A *COMPACT WARDROBE*, FOR INSTANCE IN A CHILD'S ROOM, TO BECOMING A *GENEROUS KITCHEN CABINET*, OR ...

KIN BIG//Kommode mit Holzsockel
Eiche, Massivholz

***KIN BIG*// Cabinet with plinth in wood
oak, solid wood**

... AUS EINER GROSSEN
EINZELKOMMODE
IM SCHLAFZIMMER EIN *FLURMÖBEL*.



... AS A LARGE *SINGLE BEDROOM*
DRESSER THAT TURNS INTO A PIECE
OF *HALLWAY FURNITURE*.

KIN BIG//Kommode mit Holzsockel
amerikanischer Nussbaum, Massivholz

KIN BIG// Cabinet with plinth in wood
American walnut, solid wood

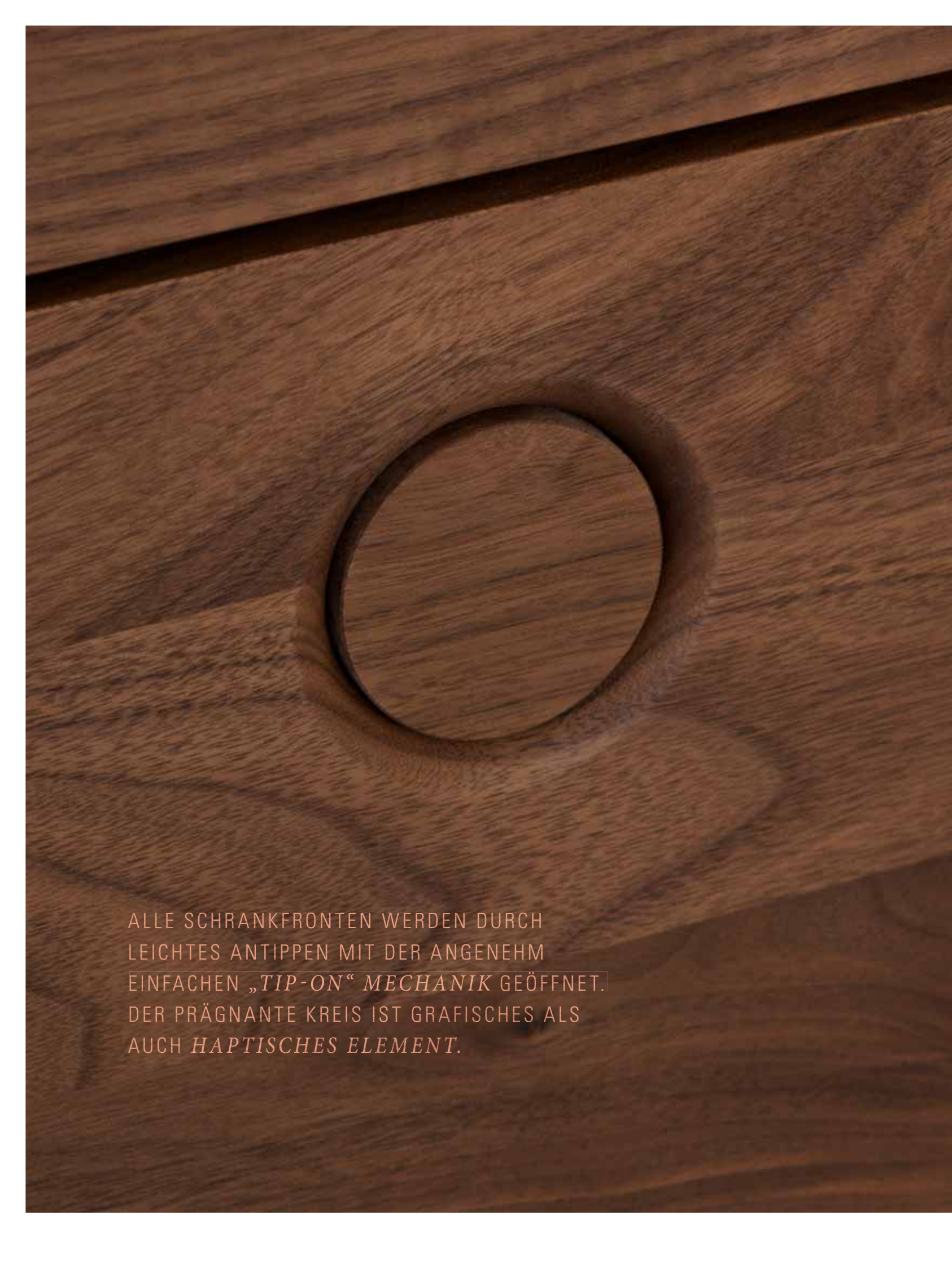
A close-up photograph of a dark-stained wooden cabinet door. The wood grain is clearly visible, running diagonally from the top-left to the bottom-right. In the center of the door, there is a circular hole. The hole is surrounded by a slightly raised, circular rim, which is the 'tip-on' mechanism mentioned in the text. The lighting is soft, highlighting the texture of the wood.

ALLE SCHRANKFRONTEN WERDEN DURCH
LEICHTES ANTIPPEN MIT DER ANGENEHM
EINFACHEN „*TIP-ON*“ *MECHANIK* GEÖFFNET.
DER PRÄGNANTE KREIS IST GRAFISCHES ALS
AUCH *HAPTISCHES ELEMENT*.

ALL CABINET FRONTS ARE OPENED
EASILY WITH THE "TIP-ON" MECHANISM
BY GENTLY TAPPING. THE DISTINGUISHING
CIRCLE SERVES BOTH AS A GRAPHIC
AND A TACTILE ELEMENT.



KIN BIG//Kommode mit Holzsockel
amerikanischer Nussbaum, Massivholz

KIN BIG// Cabinet with plinth in wood
American walnut, solid wood

L



SIDEBOARD

SIDEBOARD

O

N

G

I



KIN LONG// Sideboard, Eiche kalk gebeizt, Massivholz

mit KIN Base 2, Gestell Stahl weiß (RAL 9016) matt pulverbeschichtet, h 25 cm

KIN LONG// Sideboard, Eiche, Massivholz

mit KIN Base 2, Gestell Stahl steingrau (RAL 7030) matt pulverbeschichtet, h 25 cm (rechte Seite)

und KIN BASE 1, Holzsockel, Massivholz (linke Seite)

.....
***KIN LONG*// Sideboard, oak stained chalk, solid wood**

with KIN Base 2, frame steel white (RAL 9016) matt powder coated, h 25 cm

***KIN LONG*// Sideboard, oak, solid wood**

with KIN BASE 2, frame steel stone grey (RAL 7030) matt powder coated, h 25 cm (right page)

and KIN BASE 1, plinth in solid wood (left page)





KIN LONG // Sideboard, Eiche, Massivholz
mit KIN Base 2, Gestell Stahl steingrau (RAL 7030) matt pulverbeschichtet, h 25 cm

KIN LONG // Sideboard, oak, solid wood
with KIN Base 2, frame steel stone grey (RAL 7030) matt powder coated, h 25 cm

BEISTELLMÖBEL



SIDE CABINET



KIN TINY // Beistellmöbel mit Holzsockel, Eiche, Massivholz
FRIDAY 2 // Polstermöbel, 2-Sitzer, Gestell Eiche, Massivholz
Stoff Steelcut Trio 2 413, Kvadrat mit *ARA* // Kissen, Stoff Haakon 2 422, Kvadrat

***KIN TINY* // Side cabinet with plinth in wood, oak, solid wood**
***FRIDAY 2* // Upholstery, 2-seater, frame oak, solid wood**
fabric Steelcut Trio 2 413, Kvadrat with *ARA* // Cushion, fabric Haakon 2 422, Kvadrat

WIR ZIEHEN UM –
EIN – AUS – ZUSAMMEN ...

Unser
Bedürfnis
nach Stauraum
ist wie
das Leben
selbst –
von
ständigem
Wandel
gekennzeichnet.



Der Gedanke,
einzelne Schrankelemente
nach Belieben
einer neuen Nutzung
zuschreiben zu können,
ist gleichermassen
Programm,
wie die Möglichkeit
individuelle Lösungen
zu finden.

KIN TINY// Beistellmöbel, Eiche mohn lasiert (RAL 2002), Massivholz
KIN BIG// Kommode, Eiche, Massivholz
mit KIN Base 2, Gestell Stahl steingrau (RAL 7030) matt pulverbeschichtet, h 25 cm

***KIN TINY*// Side cabinet, oak glazed poppy (RAL 2002), solid wood**
***KIN BIG*// Cabinet, oak, solid wood**
with KIN Base 2, frame steel stone grey (RAL 7030) matt powder coated, h 25 cm

**WE ARE MOVING –
IN – OUT – TOGETHER ...**

Like
life
itself,
our
storage
needs
are
marked by
constant
change.



The concept of
being able to find
new uses for
the individual
elements is
as much part
of the programme
as their ability
to create
new solutions.

KIN BIG // Kommode, Eiche kaltgrau gebeizt, Massivholz
KIN LONG // Sideboard mit Holzsockel, Eiche, Massivholz

***KIN BIG* // Cabinet, oak stained cold grey, solid wood
KIN LONG // Sideboard with plinth in wood, oak, solid wood**



KIN LONG // Sideboard mit und ohne Holzsockel
Eiche, Eiche kalk gebeizt und amerikanischer Nussbaum, Massivholz

***KIN LONG* // Sideboard with and without plinth in wood
oak, oak stained chalk and American walnut, solid wood**

BEWUSST SCHLICHT

INTENTIONAL SIMPLICITY

Die unterschiedlichen
Stauraumelemente
können als
akzentgebendes Solitär
oder sich im
Hintergrund haltende
Kombination
eingesetzt werden.

The various storage
elements can be
used as a highlighting
stand-alone piece
of furniture
or move towards
the background
as part of an ensemble.



KIN LONG//Sideboard, Eiche kalk gebeizt, Massivholz
mit KIN Base 2, Gestell Stahl weiß (RAL 9016) matt pulverbeschichtet, h 25 cm

KIN LONG//Sideboard, Eiche, Massivholz

KIN TINY//Beistellmöbel, amerikanischer Nussbaum, Massivholz

***KIN LONG*// Sideboard, oak stained chalk, solid wood
with KIN Base 2, frame steel white (RAL 9016) matt powder coated, h 25 cm**

***KIN LONG*//Sideboard, oak, solid wood**

***KIN TINY*// Side cabinet, American walnut, solid wood**

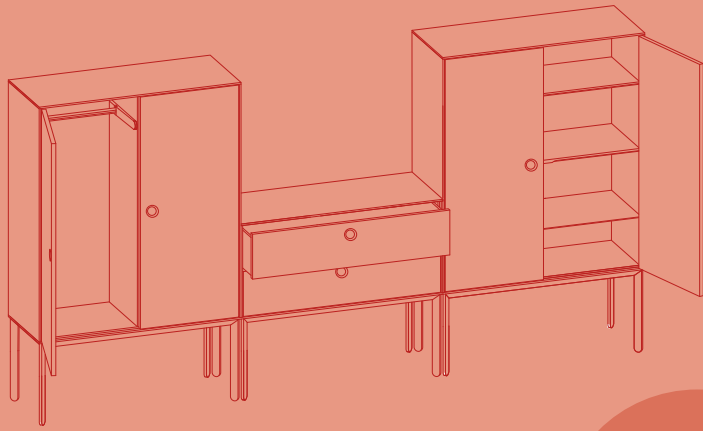

Zur
Kippsicherung
Wandfixierung
erforderlich!

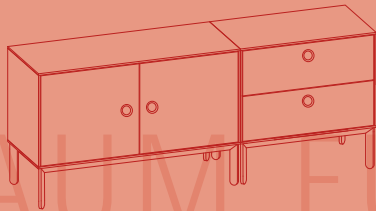
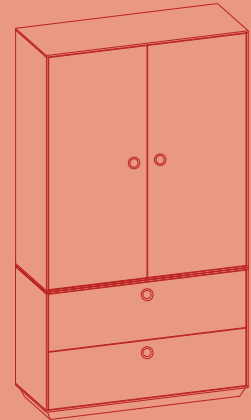

RAUM FÜR IDEEN
IDEEN ZUM SPIELEN
SPIELEN IM RAUM

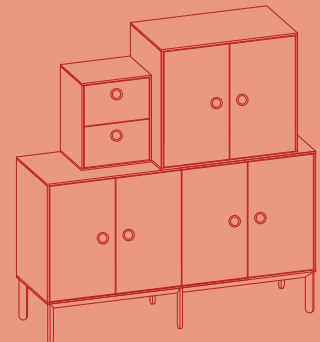
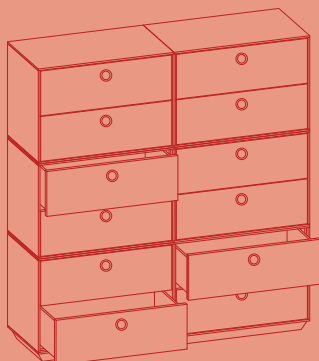
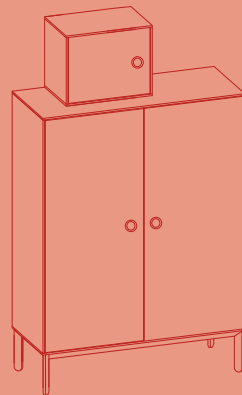
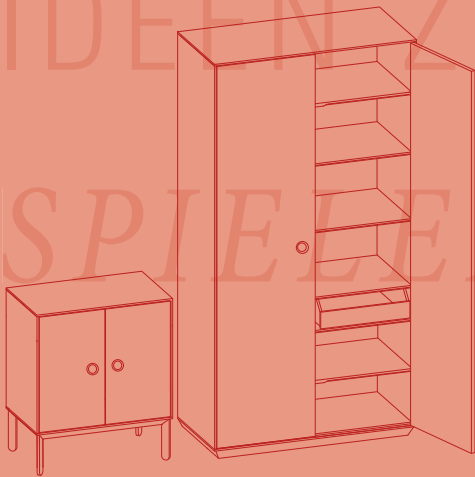

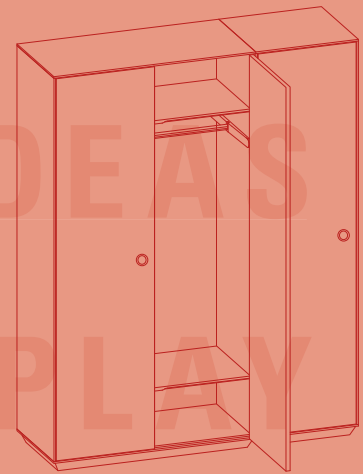
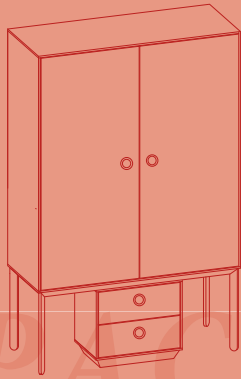
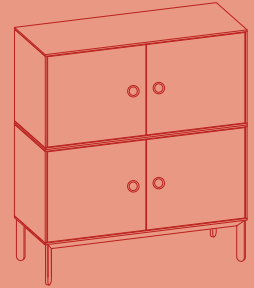
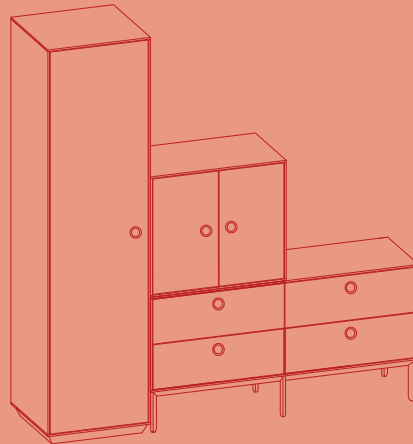
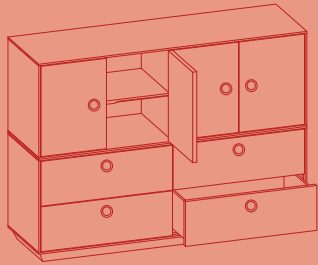

SPACE FOR IDEAS

IDEAS FOR PLAY

PLAYING SPACE

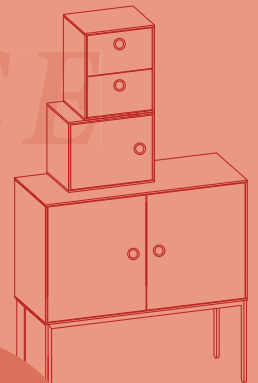
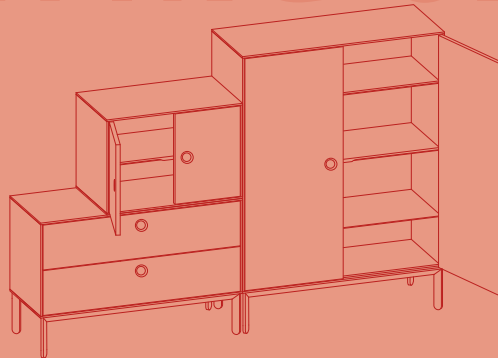
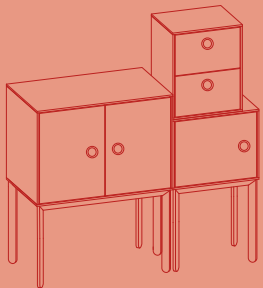

To prevent tipping wall mounting required!

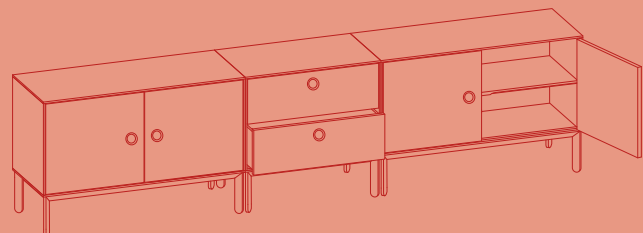
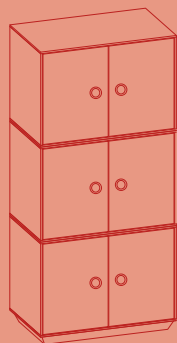

AUF DIE *BEINE* GESTELLT

Das
Untergestell
ist als
integriertes Element
gestaltet.
Dadurch
verschmilzt der
Massivholzkorpus
mit dem Gestell aus
pulverbeschichtetem
Stahl.



Die
Gestellfarben
sind mit den
Naturholz- und
Beiztönen
so abgestimmt,
dass sich
ein harmonisches,
monochromes
Gesamtbild ergibt.

KIN LONG // Sideboard, Eiche mohn lasiert (RAL 2002), Massivholz
mit KIN Base 3, Gestell Stahl mohn (RAL 2002) matt pulverbeschichtet, h 50 cm

***KIN LONG* // Sideboard, oak glazed poppy (RAL 2002), solid wood
with KIN Base 3, frame steel poppy (RAL 2002) matt powder coated, h 50 cm**

STANDING ON ITS OWN FEET

The frame is designed to be an integrated element. As a result the wooden compartment merges with the matt powder coated steel frame.



The frame colours are perfectly matched to the tones of the natural and stained timbers, generating a harmonious, monochromatic appearance.

KIN LONG // Sideboard, Eiche, Massivholz
mit KIN Base 3, Gestell Stahl steingrau (RAL 7030) matt pulverbeschichtet, h 50 cm

KIN LONG // Sideboard, oak, solid wood
with KIN Base 3, frame steel stone grey (RAL 7030) matt powder coated, h 50 cm



DIE GESTELLVARIANTEN BIETEN
KOMBINATIONSMÖGLICHKEITEN,
DIE AUCH FÜR
UNKONVENTIONELLE
ANWENDUNGEN LÖSUNGEN
BEREITHALTEN.

A close-up photograph showing the corner of a dark-stained wooden frame. The frame is composed of several thick, rectangular sections. One section is horizontal at the top, another is vertical on the right, and a third is diagonal, meeting the vertical one at a 45-degree angle. The wood grain is clearly visible. To the left, a white wall or panel is visible, with a thin, dark line indicating a joint or shadow. The lighting is soft, creating subtle shadows and highlights on the wood's surface.

**THE DIFFERENT FRAME OPTIONS
PROVIDE *VARIOUS COMBINATIONS*
WHICH OFFER SOLUTIONS EVEN
IN *UNCONVENTIONAL SETTINGS*.**



KIN LONG // Sideboard, Eiche rauchblau gebeizt, Massivholz
mit KIN Base 2, Gestell Stahl steingrau (RAL 7030) matt pulverbeschichtet, h 25 cm
FRIDAY 1 // Sessel, Gestell Eiche, Massivholz
rückseitig Kernleder natur, Polster Stoff Coda 2 722, Kvadrat
READ NOON // Stehleuchte, Schirm textil weiß, Gestell Eisen mattschwarz pulverbeschichtet

***KIN LONG* // Sideboard, oak stained smoke blue, solid wood
with KIN Base 2, frame steel stone grey (RAL 7030) matt powder coated, h 25 cm
FRIDAY 2 // Armchair, frame oak, solid wood
rear sleek leather natural, upholstery fabric Coda 2 722, Kvadrat
READ NOON // Reading lamp, lampshade textile white, frame iron matt black powder coated**





KIN LONG // Sideboard, amerikanischer Nussbaum, Massivholz, Maserung durchlaufend
mit KIN Base 2, Gestell Stahl mattschwarz (RAL 9005) pulverbeschichtet, h 25 cm

MORPH DINING // Stuhl, Gestell amerikanischer Nussbaum, Massivholz
Polster außen Stoff Pilot 792, Raf Simons, Polster innen Stoff Harald 2 792 und 192, Kvadrat

TURNTABLE // Tisch, amerikanischer Nussbaum, Massivholz, Ø 140 cm

KIN LONG // Sideboard, American walnut, solid wood, continuous grain
with KIN Base 2, frame steel matt black (RAL 9005) powder coated, h 25 cm

MORPH DINING // Dining chair, frame American walnut, solid wood
upholstery outside fabric Pilot 792, Raf Simons, upholstery inside fabric Harald 2 792 and 192, Kvadrat

TURNTABLE // Table, American walnut, solid wood, Ø 140 cm



KIN BIETET DURCH SEINE
VIELSEITIGKEIT EINE ALTERNATIVE ZU
THEMATISCHEN SCHRANKMÖBELN,
DIE SOBALD SICH DER KONTEXT ÄNDERT
IHRE GÜLTIGKEIT VERLIEREN.



KIN TINY//Beistellmöbel, Eiche mohn lasiert (RAL 2002), Massivholz
mit KIN Base 2, Gestell Stahl mohn (RAL 2002) matt pulverbeschichtet, h 25 cm
M 11 DESK//Tisch mit Staufach, Eiche, Massivholz
große Platte einseitig aufschiebbar, l 145/199 cm
NONOTO//Stuhl, Eiche, Massivholz, Festpolster Stoff Revive 2 523, Kvadrat

***KIN TINY*//Side cabinet, oak glazed poppy (RAL 2002), solid wood
with KIN Base 2, frame steel poppy (RAL 2002) matt powder coated, h 25 cm
M 11 DESK//Table with storage, oak, solid wood
big plate movable to one side, l 145/199 cm
NONOTO// Chair, oak, solid wood, close upholstery fabric Revive 2 523, Kvadrat**

THROUGH ITS *VERSATILITY*
KIN PROVIDES AN ALTERNATIVE
TO THEMED CABINET FURNITURE
THAT BECOMES INVALID
IN A DIFFERENT SETTING.



KIN LONG // Sideboard, Eiche mohn lasiert (RAL 2002), Massivholz
mit KIN Base 3, Gestell Stahl mohn (RAL 2002) matt pulverbeschichtet, h 50 cm
RAIL // Tisch, Eiche, Massivholz mit Ansatzplatten, Eiche kalk gebeizt, Massivholz, l 180/280 cm
1.3 *CHAIR* // Stuhl, Eiche, Massivholz, Festpolster Leder Jopard cognac, Reinhardt und Stoff Steelcut 2 535
und 550, Kvadrat mit 1.3 *STOOL* // Hocker, Eiche, Massivholz, Festpolster Stoff Steelcut 2 615, 660 und 545, Kvadrat

.....

***KIN LONG* // Sideboard, oak glazed poppy (RAL 2002), solid wood
with KIN Base 3, frame steel poppy (RAL 2002) matt powder coated, h 50 cm
RAIL // Table, oak, solid wood with extension, oak stained chalk, solid wood, l 180/280 cm
1.3 *CHAIR* // Chair, oak, solid wood, close upholstery leather Jopard cognac, Reinhardt
and fabric Steelcut 2 535 and 550, Kvadrat
1.3 *STOOL* // Stool, oak, solid wood, close upholstery fabric Steelcut 2 615, 660 and 545, Kvadrat**



NEBEN DER FARBLICH NEUTRALEN
ABSTUFUNG VON KALK BIS GRAPHITSCHWARZ
UND DEN NATURHOLZTÖNEN SETZT DIE
NEUE FARBE MOHN AKZENTE ALS
ELEMENTARER KLASSISCHER FARBTON.

IN ADDITION TO THE NEUTRAL
SHADES FROM CHALK TO
GRAPHITE BLACK, AND THE
NATURAL WOOD TONES, POPPY
ESTABLISHES ITSELF AS A
CLASSIC ELEMENTARY COLOUR.







KIN TINY// Beistellmöbel mit Holzsockel, Eiche, Massivholz

GRAND MELLOW// Bett, Gestell Eiche, Massivholz

Rückenkissen Leder Jopard schlammgrau, Reinhardt, Lederschnur pastellrauchblau

DAYDREAM// Tagesdecke, Stoff Pause 4 254, Kvadrat

und Überwurf, Stoff Topia messing, Rohi

NEAT NOON// Tischleuchte, Schirm textil warmgrau, Gestell Eisen mattschwarz pulverbeschichtet, Diffusorscheibe

***KIN TINY*// Side cabinet with plinth in wood, oak, solid wood**

***GRAND MELLOW*// Bed, frame oak, solid wood**

back cushions leather Jopard schlammgrau, Reinhardt, leather strap pastel smoke blue

***DAYDREAM*// Coverlet, fabric Pause 4 254, Kvadrat**

and plaid, fabric Topia messing, Rohi

***NEAT NOON*// Table lamp, lampshade textile warmgrey, frame iron matt black powder coated, diffusor**

KIN TINY

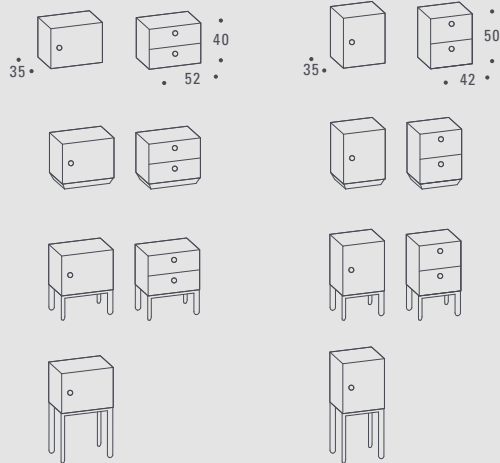

STAUARAUM-SYSTEM, BEISTELLMÖBEL, MASSIVHOLZ

Eiche, amerikan. Nussbaum, horizontaler Maserungsverlauf

Türen mit Tip-on Beschlag, Schübe mit Selbsteinzug, Elemente ohne Sockel auch stapelbar
erhältlich mit KIN Base: Holzsockel oder Stahlgestell matt pulverbeschichtet:

weiß (RAL 9016), steingrau (RAL 7030), mattschwarz (RAL 9005), mohn (RAL 2002)

KIN TINY Schub nicht kombinierbar mit KIN Base 3

Türen: Ausführungen in spiegelverkehrter Anordnung erhältlich

KIN TINY Tür: 1 Fachboden im Lieferumfang enthalten

STORAGE SYSTEM, SIDE CABINET, SOLID WOOD

Oak, American walnut, horizontal graining

doors with Tip-on binder, drawer with self-closing, elements without plinth stackable

available with KIN Base: plinth in wood or steel frame matt powder coated:

white (RAL 9016), stone grey (RAL 7030), matt black (RAL 9005), poppy (RAL 2002)

KIN TINY Drawer not combinable with KIN Base 3

doors: mirror-inverted available

KIN TINY Door: 1 shelf included in delivery

KIN BIG

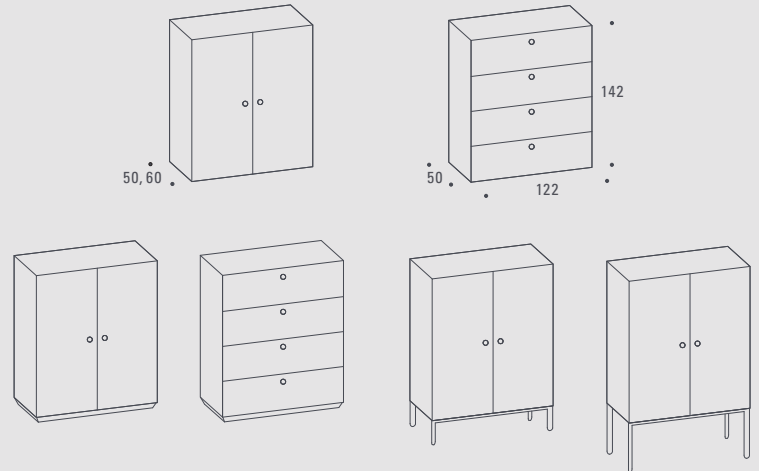

STAUARAUM-SYSTEM, KOMMODE, MASSIVHOLZ

Eiche, amerikan. Nussbaum

KIN BIG Tür: mit Tip-on Beschlag, vertikaler Maserungsverlauf

Innenausstattung frei wählbar mit Add-ons: KIN Hang, KIN Shelf, KIN Drawer, KIN Flat, inkl. Mittelwand
erhältlich mit KIN Base: Holzsockel oder Stahlgestell matt pulverbeschichtet:

weiß (RAL 9016), steingrau (RAL 7030), mattschwarz (RAL 9005), mohn (RAL 2002)

1 Fachboden und 1 Kleiderstange im Lieferumfang enthalten

KIN BIG Schub: mit Selbsteinzug, horizontaler Maserungsverlauf

erhältlich nur mit KIN Base 1

STORAGE SYSTEM, CABINET, SOLID WOOD

Oak, American walnut

KIN BIG doors: with Tip-on binder, vertical graining

interiors selectable with add-ons: KIN Hang, KIN Shelf, KIN Drawer, KIN Flat, incl. center wall

available with KIN Base: plinth in wood or steel frame matt powder coated:

white (RAL 9016), stone grey (RAL 7030), matt black (RAL 9005), poppy (RAL 2002)

1 shelf and 1 clothes rail set included in delivery

KIN BIG drawer: with self-closing, horizontal graining

available only with KIN Base 1

KIN TALL

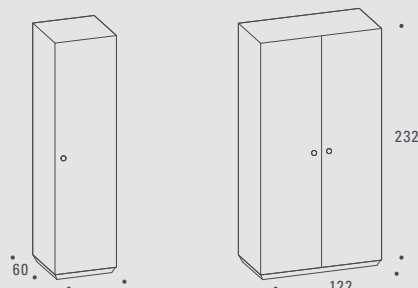

STAUARAUM-SYSTEM, SCHRANK, EIN-/ ZWEITÜRIG, MASSIVHOLZ

Eiche, amerikan. Nussbaum, vertikaler Maserungsverlauf, zerlegbar

Holzsockel h 6 cm, Türen mit Tip-on Beschlag

2 Fachböden im Lieferumfang enthalten – bei KIN TALL 2 Mittelwand wahlweise erhältlich

STORAGE SYSTEM, WARDROBE, SINGLE / DOUBLE-DOOR, SOLID WOOD

Oak, American walnut, vertical graining, demountable

wooden plinth h 6 cm, doors with Tip-on binder

2 shelves included in delivery – at KIN TALL 2 center wall optionally available

Innenausstattung – Holzart wie Korpus – frei wählbar mit Add-ons:

KIN Hang, KIN Shelf, KIN Drawer, KIN Flat

KIN TALL 1: Ausführungen in spiegelverkehrter Anordnung erhältlich

interiors – type of wood like body – selectable with add-ons:

KIN Hang, KIN Shelf, KIN Drawer, KIN Flat

KIN TALL 1: mirror-inverted available

KIN LONG

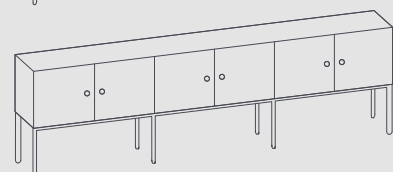
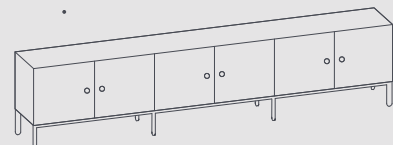
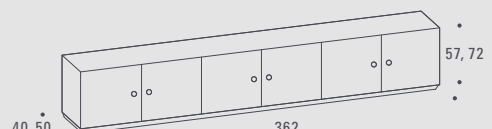
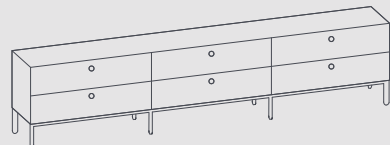
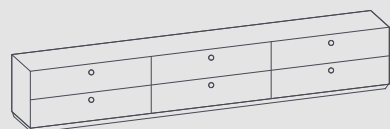
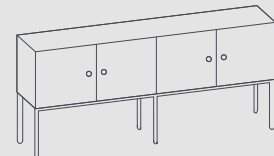
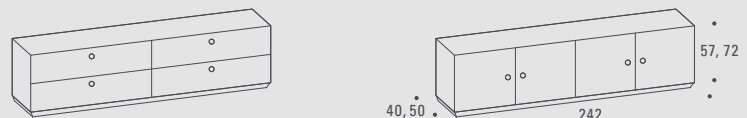
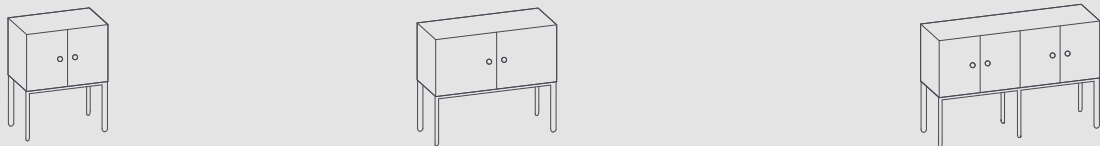
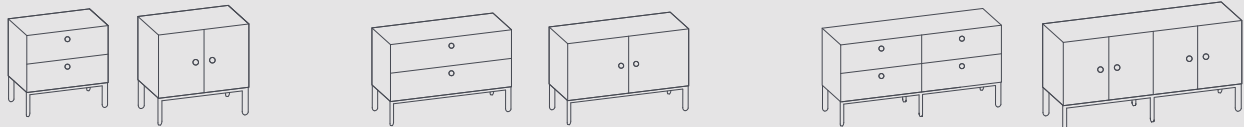
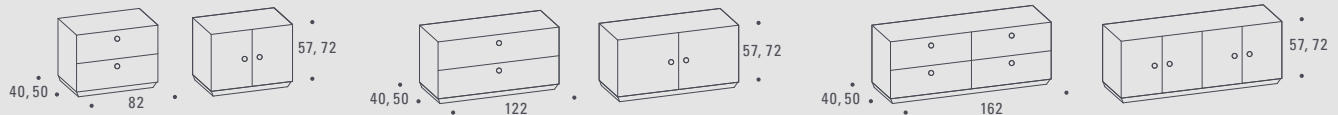

STAURAUM-SYSTEM, SIDEBOARD, MASSIVHOLZ

Eiche, amerikan. Nussbaum, horizontaler Maserungsverlauf
Türen mit Tip-on Beschlag, Schübe mit Selbsteinzug, Elemente ohne Sockel auch stapelbar
ab b 122 mit Mittelwand
Ausführung mit Türen: pro Fach 1 Fachboden im Lieferumfang enthalten

erhältlich mit KIN Base: Holzsockel oder Stahlgestell matt pulverbeschichtet:
weiß (RAL 9016), steingrau (RAL 7030), mattschwarz (RAL 9005), mohn (RAL 2002)
Innenausstattung frei wählbar mit Add-ons: KIN Shelf, KIN Drawer, KIN Flat
KIN LONG Schub nicht kombinierbar mit KIN Base 3

STORAGE SYSTEM, SIDEBOARD, SOLID WOOD

Oak, American walnut, horizontal graining
doors with Tip-on binder, drawer with self-closing, elements without plinth stackable
from b 122 with center wall
model with doors: per case 1 shelf included in delivery

available with KIN Base: plinth in wood or steel frame matt powder coated:
white (RAL 9016), stone grey (RAL 7030), matt black (RAL 9005), poppy (RAL 2002)
interiors selectable with add-ons: KIN Shelf, KIN Drawer, KIN Flat
KIN LONG Drawer not combinable with KIN Base 3

KIN Base



KIN Base 1

Holzsockel // **Wooden base**

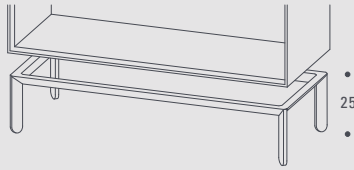

KIN Base 2

Metallgestell niedrig // **Metal base low**



KIN Base 3

Metallgestell hoch // **Metal base high**

*KIN BASE: STAURAUM-SYSTEM, HOLZSOCKEL, MASSIVHOLZ
ODER STAHLGESTELL MATT PULVERBESCHICHTET MIT MASSIVHOLZ-BLENDE*
Holzsockel: Eiche, amerikan. Nussbaum oder Stahlgestell matt pulverbeschichtet:
weiß (RAL 9016), steingrau (RAL 7030), mattschwarz (RAL 9005), mohn (RAL 2002)
inkl. Verstellfüße max. h 10 mm

*KIN BASE: STORAGE SYSTEM, PLINTH, SOLID WOOD
OR FRAME STEEL MATT POWDER COATED WITH SOLID WOOD COVER*
plinth in wood: oak, American walnut, or steel frame matt powder coated:
white (RAL 9016), stone grey (RAL 7030), matt black (RAL 9005), poppy (RAL 2002)
incl. adjustable feet max. h 10 mm

KIN Add-ons

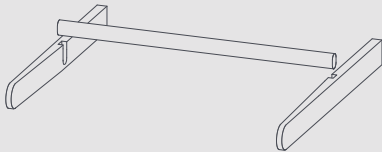

KIN Hang

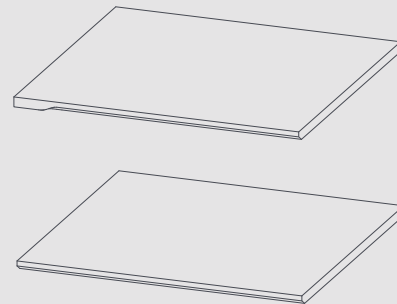

KIN Shelf

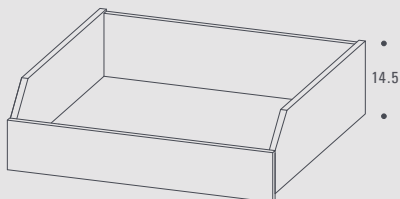

KIN Drawer



KIN Flat

*KIN HANG: STAURAUM-SYSTEM,
KLEIDERSTANGEN-SET, MASSIVHOLZ*
Eiche, amerikan. Nussbaum

*KIN DRAWER: STAURAUM-SYSTEM,
INNENSCHUB*
Eiche, amerikan. Nussbaum
Schübe mit Vollauszug, Holzart wie Korpus

*KIN SHELF: STAURAUM-SYSTEM,
EINLEGEBOEDEN, MASSIVHOLZ*
Eiche, amerikan. Nussbaum
mit Kantenprofil 10 mm
bei Bedarf mit Tip-on Beschlag ausgestattet

*KIN FLAT: STAURAUM-SYSTEM,
TABLAR*
Tablar mit Vollauszug
Holzart wie Korpus

*KIN HANG: STORAGE SYSTEM,
CLOTHES RAIL SET, SOLID WOOD*
Oak, American walnut

*KIN DRAWER: STORAGE SYSTEM,
INSET DRAWER*
Oak, American walnut, drawer with full
extension, type of wood like body

*KIN SHELF: STORAGE SYSTEM,
SHELVES, SOLID WOOD*
Oak, American walnut
with edge profile 10 mm
fitted if necessary with Tip-on binder

*KIN FLAT: STORAGE SYSTEM,
TABLAR*
Tablar with full extension
type of wood like body

GRUNDAUSSTATTUNG // **BASIC CONFIGURATION**

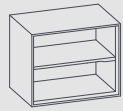

KIN TINY

- 1 × KIN Shelf

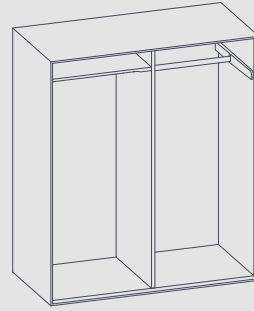
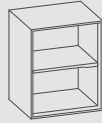

KIN BIG

inkl. Mittelwand // **incl. center wall**

- 1 × KIN Hang
- 1 × KIN Shelf

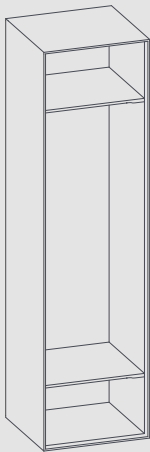

KIN TALL 1

- 2 × KIN Shelf

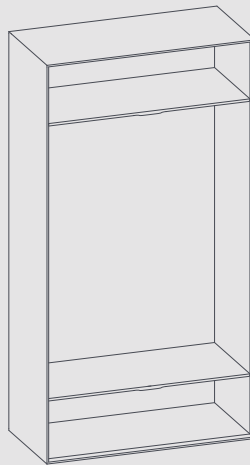

KIN TALL 2

- 2 × KIN Shelf

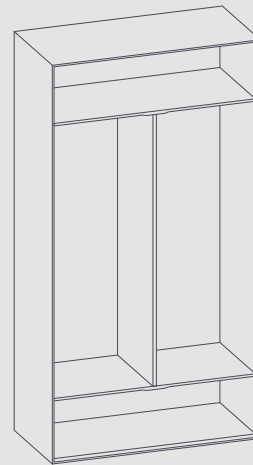

KIN TALL 2

oder // **or**

inkl. Mittelwand // **incl. center wall**

- 2 × KIN Shelf

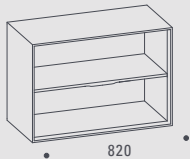

KIN LONG

- 1 × KIN Shelf

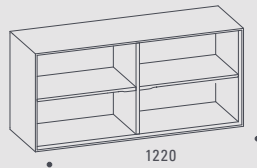

KIN LONG

inkl. Mittelwand // **incl. center wall**

- 2 × KIN Shelf

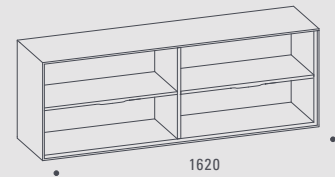

KIN LONG

inkl. Mittelwand // **incl. center wall**

- 2 × KIN Shelf

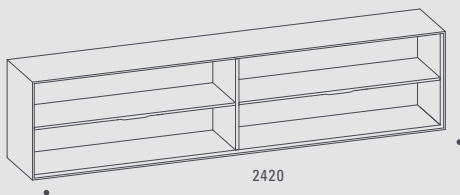

KIN LONG

inkl. Mittelwand // **incl. center wall**

- 2 × KIN Shelf

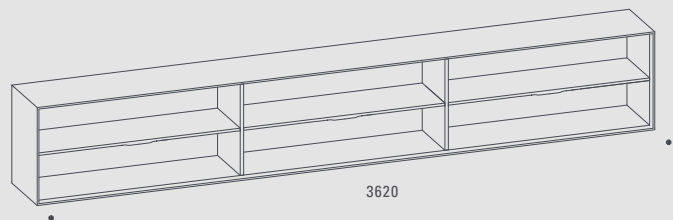

KIN LONG

inkl. 2 Mittelwände // **incl. 2 center walls**

- 3 × KIN Shelf
-

Zur Kippsicherung
Wandfixierung erforderlich

To prevent tipping
wall mounting required

- SIE HABEN
DIE WAHL:
PLEASE TAKE
YOUR CHOICE:
- 1 Korpusart
Type of body
 - 2 Außenschübe oder Türen
Outside drawers or doors
 - 3 Gestellvariante & Innenausstattung
Type of base & interior fittings
 - 4 Holzart und Farbbeize
Type of wood & colour stain

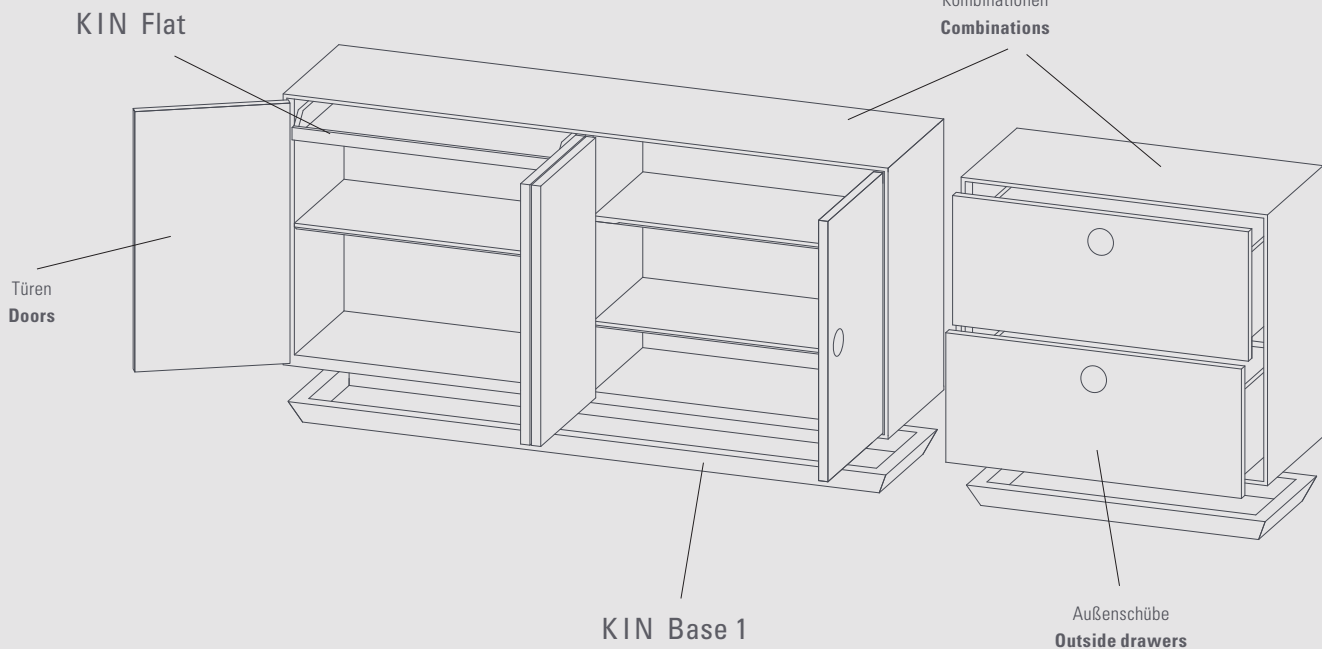
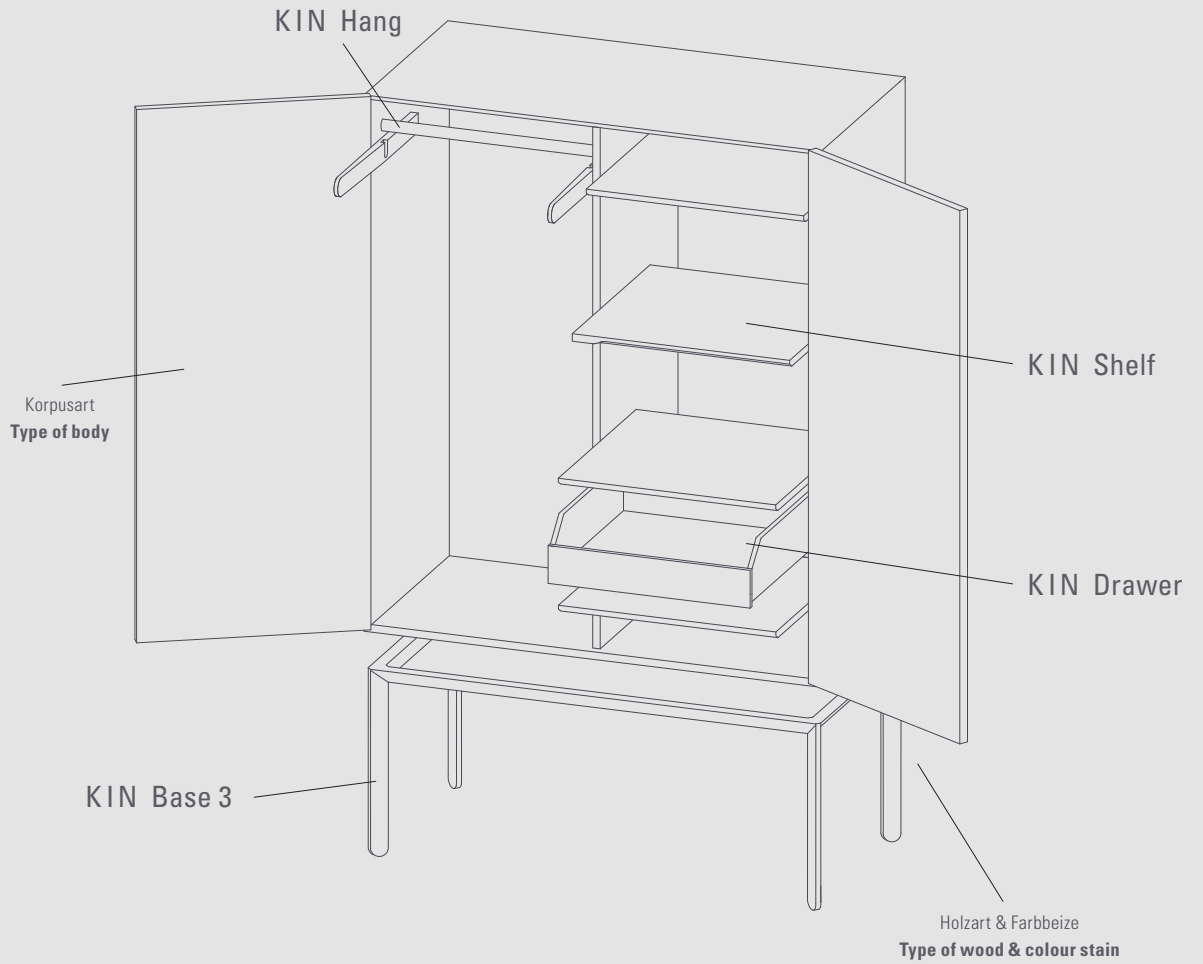

MASSIVHOLZ // **SOLID WOOD**

FARBLASUR EICHE // **COLOUR GLAZE OAK**



EICHE
OAK



AMERIKANISCHER NUSSBAUM
AMERICAN WALNUT



MOHN – RAL 2002
POPPY – RAL 2002

FARBBEIZE EICHE // **COLOUR STAIN OAK**



KALK
CHALK



WARMGRAU HELL
LIGHT WARM GREY

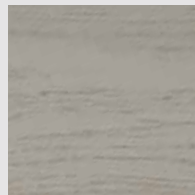

KALTGRAU
COLD GREY



RAUCHBLAU
SMOKE BLUE

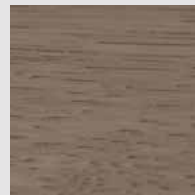

WARMGRAU DUNKEL
DARK WARM GREY



GRAPHITGRAU
GRAPHITE GREY

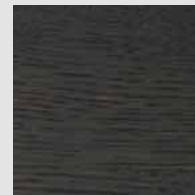

GRAPHITSCHWARZ
GRAPHITE BLACK



WASSERBLAU
AQUA BLUE



MINTBLAU
MINT BLUE



LACHSROSA
SALMON PINK



PASTELLROSA
PINK PASTEL

GESTELLFARBEN – MATT PULVERBESCHICHTET
FRAME COLOURS – MATT POWDER COATED

ZUORDNUNG: KORPUS & GESTELL & STELLFÜSSE
ASSIGNMENT: BODY & FRAME & ADJUSTABLE FEET

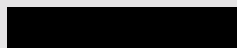

MATTSCHWARZ – RAL 9005
MATT BLACK – RAL 9005



STEINGRAU – RAL 7030
STONE GREY – RAL 7030

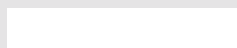

WEISS – RAL 9016
WHITE – RAL 9016



MOHN – RAL 2002
POPPY – RAL 2002

AMERIKAN. NUSSBAUM NATUR – MATTSCHWARZ (RAL 9005) – SCHWARZ
AMERICAN WALNUT NATURAL – MATT BLACK (RAL 9005) – BLACK



EICHE NATUR – STEINGRAU (RAL 7030) – GRAU
OAK NATURAL – STONE GREY (RAL 7030) – GREY



EICHE KALK GEBEIZT – WEISS (RAL 9016) – WEISS
OAK STAINED CHALK – WHITE (RAL 9016) – WHITE



EICHE KALTGRAU GEBEIZT – STEINGRAU (RAL 7030) – GRAU
OAK STAINED COLD GREY – STONE GREY (RAL 7030) – GREY



EICHE GRAPHITSCHWARZ GEBEIZT – MATTSCHWARZ (RAL 9005) – SCHWARZ
OAK STAINED GRAPHITE BLACK – MATT BLACK (RAL 9005) – BLACK

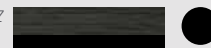

EICHE RAUCHBLAU GEBEIZT – STEINGRAU (RAL 7030) – GRAU
OAK STAINED SMOKE BLUE – STONE GREY (RAL 7030) – GREY



EICHE MOHN LASIERT – MOHN (RAL 2002) – GRAU
OAK GLAZED POPPY – POPPY (RAL 2002) – GREY



RAUM ALS WERT



SPACE AS VALUE

2016 BY ZEITRAUM GMBH

Äußere Münchner Straße 2 // D-82515 Wolfratshausen

www.zeitraum-moebel.de

.....

ARTDIREKTION – ART DIRECTION

ZEITRAUM, Wolfratshausen

FOTOGRAFIE – PHOTOGRAPHY

Team Schalterhalle, München

BILDBEARBEITUNG – PICTURE EDITING

Franziska Rohlfing, München

ZEITRAUM, Wolfratshausen

REDAKTION – EDITORIAL

Mathias Hahn, London

ZEITRAUM, Wolfratshausen

ÜBERSETZUNG – TRANSLATION

Global Syntax, München

Peter Corbishley, München

PRODUKTION & DRUCK – PRODUCTION & PRINT

F&W Druck- und Mediacenter GmbH, Kienberg

.....

Aus drucktechnischen Gründen sind Farbabweichungen möglich.

For typographical reasons colour variations are possible.

.....

TECHNISCHE ÄNDERUNGEN VORBEHALTEN –

SUBJECT TO TECHNICAL CHANGES

01.2016

RAUM ALS WERT



SPACE AS VALUE

