

# Collections

noorth

milldue edition

Collections

A Journey  
Beyond  
the Project

Colours  
Lines  
Materials

noorth

milldue edition

Il racconto della collezione Noorth attraverso soluzioni ambientate, scenari evocativi e approfondimenti tecnici. Un volume dedicato al bagno contemporaneo, legato al tema delle emozioni e del benessere, in cui la proposta Noorth appare nella sua totalità. Un viaggio che va oltre l'estetica e la funzionalità per approfondire il tema del comfort in ambienti curati ed esclusivi, dove il dialogo fra volumi, superfici e linee si traduce in un'eleganza sofisticata e senza tempo.

The story of the Noorth collection through ambient solutions, evocative scenarios and technical insights. A volume dedicated to the contemporary bathroom, linked to the theme of emotions and well-being, in which the Noorth line appears in its entirety. A journey that goes beyond aesthetics and beyond functionality to delve deeper into the theme of comfort in a refined and exclusive environment, where the dialogue between volumes, surfaces and lines translates into a sophisticated and timeless elegance.

L'histoire de la collection Noorth à travers des solutions encadrées, des scénarios évocateurs et des approfondissements techniques. Un volume dédié à la salle de bain contemporaine, lié au sujet des émotions et du bien-être, où la ligne Noorth apparaît dans sa totalité. Un voyage qui va au-delà de l'esthétique et de la fonctionnalité pour approfondir le thème du confort dans un environnement soigné et exclusif, dans lequel le dialogue entre volumes, surfaces et lignes se traduit dans une élégance sophistiquée et sans âge.

Die Schilderung der Noorth Kollektion anhand von Einrichtungs-lösungen, aussagestarken Szenarios und technischen Erläuterungen. Ein Buch, das sich dem modernen Badezimmer widmet, einem Bereich, wo sich alles um Emotionen und Wohlbefinden dreht und wo der Stil von Noorth in all seiner Komplexität zur Entfaltung kommt. Eine Reise, die über reine Ästhetik und Funktionalität hinausgeht, denn hier wird das Thema Komfort in einem gepflegten, exklusiven Ambiente vertieft, das den Dialog zwischen Raum, Flächen und Linien in einer raffinierten, zeitlosen Eleganz widerspiegelt.

Рассказ о коллекции Noorth через конкретные решения для помещений, запоминающиеся сцены и более глубокие технические знания. Пространство, предназначенное для современной ванной комнаты, неотрывно связанной с эмоциями и ощущением комфорта, в котором линия Noorth полностью вписывается. Путешествие за пределы эстетики и функциональности, чтобы глубже коснуться темы комфорта тщательно продуманного и эксклюзивного помещения, в котором диалог между объемами, поверхностями и линиями превращается в изысканную элегантность, не знающую времени.

Introduction	4
Fjord Collection	15
Talking with Giuseppe Bavuso	54
Puro Collection	63
Zenit Collection	119
Azuma Collection	149
Roma Collection	171
Talking with Jeannette Altherr	188
Touch Collection	199
Sintesi Collection	215
One Collection	269
Elements	281
Technical Data	403

# Research and innovation, the basics of a life project.

Trovare soluzioni per l'arredo bagno è un'attività che impegna la nostra famiglia da due generazioni. Un percorso imprenditoriale rivolto ad un mercato sempre più internazionale che ha interpretato il forte cambiamento degli stili di vita e delle abitudini individuali degli ultimi decenni. Con il progetto Noorth, presentato nel 2016 al Salone del Bagno di Milano, ci siamo posti l'obiettivo di esprimere una visione moderna, fondata sulla ricerca e l'innovazione e ispirata ai valori di originalità e coerenza. Consapevoli che la qualità è un obiettivo che riguarda ogni fase del processo, dal design alla produzione, dalla comunicazione ai servizi pre e post vendita, ci impegniamo costantemente su ogni fronte per superare gli standard abituali. Dialoghiamo con professionisti diversi per linguaggio e sensibilità per offrire, nel rispetto di un'armonia complessiva, una proposta completa e differenziata. Perché il bagno è un ambiente particolare, con esigenze tecniche specifiche e nello stesso tempo desideri legati alla sensibilità individuale: importante quindi suggerire interpretazioni differenti, modulate su un pensiero comune e coerente. Obiettivo che rende l'ambiente bagno una dimensione ideale per il design e che per noi si traduce nella ricerca costante di un equilibrio tra tecnologia e artigianato, memoria e innovazione, logiche industriali e personalizzazione. La collezione prevede sistemi componibili integrati a una gamma di lavabi e accessori tra le più complete del settore, proposte basate sul rigore e la massima essenzialità formale affiancate da pezzi iconici, caratterizzati da una forte espressività. Noorth è oggi una realtà definita, il risultato concreto di una precisa visione, un nuovo progetto che ci stimola e ci entusiasma.

For two generations, our family has been finding solutions for bathroom furniture. An entrepreneurial path aimed at an increasingly international market that has interpreted the strong change in lifestyles and personal habits of the last decades. With the Noorth project, presented in 2016 at the Salone del Bagno in Milan, we set ourselves the goal of expressing a modern vision based on research and innovation and inspired by the values of originality and consistency. Being aware that quality is a goal that concerns each single phase of the process, from design to production, from communication to pre and post-sales services, we constantly work on all fronts to overcome usual standards. We talk to professionals of different languages and sensitivity to offer a complete and differentiated proposal, in compliance with an overall harmony. Since the bathroom is a particular environment, with specific technical needs and at the same time desires linked to individual sensitivity, it is important to suggest different interpretations, modulated on a common and coherent idea. A goal, which makes the bathroom an ideal dimension for design and which, for us, translates into the constant search for a balance

between technology and craftsmanship, memory and innovation, industrial logics and customisation. The collection includes modular systems integrated with a range of washbasins and accessories among the most complete in the industry, proposals based on rigour and maximum simplicity supported by iconic pieces that stand out by being remarkably expressive. Today, Noorth is a definite reality, the concrete result of a precise vision, a new project that stimulates us and fills us with enthusiasm.

La recherche de solutions pour l'ameublement de la salle de bain est une activité qui engage notre famille depuis deux générations. Un chemin d'entreprise tourné vers un marché de plus en plus international qui a interprété le changement radical des styles de vie et des habitudes individuelles des dernières décennies. Avec le projet Noorth, présenté en 2016 au Salone del Bagno à Milan, notre objectif est d'exprimer une vision moderne basée sur la recherche et l'innovation et inspirée des valeurs d'originalité et de cohérence. En étant conscients que la qualité est un objectif qui concerne chaque phase du processus, de la conception à la production, de la communication aux services avant et après vente, nous travaillons sans cesse sur tous les aspects pour dépasser les normes usuelles. Nous dialoguons avec différents professionnels en termes de langage et sensibilité pour offrir, dans le respect de l'harmonie générale, une proposition complète et différenciée. Parce que la salle de bain est un environnement particulier, avec des exigences techniques spécifiques et en même temps des désirs liés à une sensibilité individuelle: il est donc important de suggérer différentes interprétations, modulées sur une pensée commune et cohérente. Objectif qui fait de l'environnement de la salle de bain une dimension idéale pour la conception et qui, pour nous, se traduit par la recherche constante d'un équilibre entre technologie et artisanat, mémoire et innovation, logiques industrielles et personnalisation. La collection comprend des systèmes modulaires intégrés à une gamme d'éviers et d'accessoires parmi les plus complètes du secteur, des propositions basées sur la rigueur et une essentialité formelle maximale accompagnées de pièces iconiques caractérisées par une forte expressivité. Noorth est de nos jours une réalité bien définie, le résultat concret d'une vision précise, un nouveau projet qui nous stimule et nous remplit d'enthousiasme.

Die Kreation von Badezimmerausstattungen ist ein Betätigungsfeld, mit dem sich unsere Familie bereits seit zwei Generationen beschäftigt. Es ist eine Unternehmenstätigkeit, die sich an einen immer internationaler werdenden Markt wendet und im Laufe der letzten Jahrzehnte mit den großen Veränderungen im Lebensstil und in den persönlichen Gewohnheiten der Menschen mitgegangen ist. Mit dem

# A vision based on technology and craftsmanship.

Projekt Noorth, das 2016 auf dem Salone del Bagno in Mailand präsentiert wurde, haben wir uns das Ziel gesetzt, eine moderne Vision zum Ausdruck zu bringen, die auf Forschung und Innovation beruht und von Werten wie Originalität und Konsequenz inspiriert ist. Im Bewusstsein, dass Qualität ein jede Phase des Gesamtprozesses betreffendes Ziel ist – vom Design bis hin zur Produktion und von der Kommunikation bis zum Pre- und After-Sales Service –, ist es unser Anliegen, kontinuierlich und in jedem Aspekt die üblichen Standards zu übertreffen. Wir stehen im Dialog mit Fachleuten verschiedener Sprachen und gestalterischer Wahrnehmung, um unter Wahrung eines harmonischen Ganzen stets ein umfassendes, differenziertes Angebot zu präsentieren. Denn das Badezimmer ist ein besonderer Raum, der einerseits von spezifischen technischen Anforderungen bestimmt und andererseits an Wünsche in Verbindung mit der individuellen Sensibilität gebunden ist: Es ist also wichtig, unterschiedliche Interpretationen vorzuschlagen, die von einem gemeinsamen, konsequenten Grundgedanken geprägt sind. Ein solches Ziel lässt das Badezimmer zur idealen Dimension für einen Designer werden. Für uns spiegelt sich dieser Anspruch in der konstanten Suche nach einem Gleichgewicht zwischen Technologie und Handwerk, unvergänglichen Werten und Innovation, industrieller Logik und Personalisierung wider. Zur Kollektion gehören individuell kombinierbare Systeme sowie ein Sortiment aus Waschbecken und Zubehör, das sich als eines der vollständigsten der Branche bezeichnen kann: ein Angebot, das auf Stringenz und maximaler formeller Essenz beruht, aber auch ikonische Stücke mit starkem Charakter enthält. Noorth ist heute eine feste Form, das konkrete Ergebnis einer präzisen Vision, ein neues Projekt, das uns motiviert und begeistert.

Поиск решений для мебельной обстановки ванной комнаты – этим занимается наша семья уже во втором поколении. Бизнес, нацеленный на всё более международный рынок, связанный со значительным изменением образа жизни и индивидуальных привычек в последние десятилетия. Целью проекта Noorth, представленного в 2016 году в Милане в рамках Салона ванной комнаты, является выражение нашего видения в современном ключе, основанном на научных исследованиях и инновациях, с добавлением таких ценностей, как оригинальность и логичность решения. Хорошо осозновая, что качество – это основная цель на каждом этапе процесса, от дизайна до производства, от рекламы до пред- и послепродажного сервиса, мы постоянно стараемся превосходить по всем направлениям обычно существующие стандарты. Мы сотрудничаем с разными профессионалами, обладающими различным самовыражением и чувствительностью в целях всеобщей гармонии, чтобы создать полное и разнообразное

предложение. Поскольку ванная комната – это особое помещение, со своими специфическими техническими требованиями и, в то же время, тесно связанное с индивидуальными чувствами, очень важно предлагать различные интерпретации, модулируемые на основе общего замысла и стилистического соответствия. Цель – сделать ванную комнату идеальным пространством для дизайна, что для нас выражается в постоянном поиске гармонии между технологией и ручным мастерством, памятью и инновациями, промышленной логикой и индивидуализацией. Коллекцией предусматриваются компонуемые системы, интегрируемые с целой гаммой раковин и комплектующих, одной из самых полных в этом секторе; предложения, основанные на строгости линий и минимализме форм, дополняются отдельными элементами, ставшими настоящей иконой, наделенными высокой экспрессивностью. На сегодняшний день Noorth представляет собой четко выраженный бренд, конкретный результат определенной стратегии, новый проект, который стимулирует и воодушевляет.



# The synthesis between style and project.

A sartorial approach to the design of the bathroom

Un approccio sartoriale al progetto bagno per una collezione senza tempo, un viaggio attraverso soluzioni versatili e improntate alla massima funzionalità. Una collezione caratterizzata dall'esclusività dei materiali, dall'equilibrio dei volumi e da approfondite ricerche cromatiche; una proposta esclusiva, dai dettagli sofisticati, in cui la qualità delle lavorazioni, la ricca offerta di soluzioni e la capacità di interpretare le esigenze di contesti differenti permettono di reinterpretare la tradizione della stanza da bagno attraverso un linguaggio nuovo: una perfetta sintesi di stile e progetto. Tra memoria e modernità, tecnologia e artigianalità e tra versatilità compositiva e ricerca formale, la proposta Noorth si sviluppa in 8 collezioni nelle quali l'essenzialità delle linee viene esaltata dalle texture irripetibili dei marmi e delle essenze, dalla nuova ed esclusiva palette dei laccati, dalla trasparenza assoluta dei cristalli e dalla lucentezza dei metalli. Un attento studio sui materiali, sugli abbinamenti cromatici e sulle materie prime, permettono la realizzazione di progetti completi e definiti, offrendo prodotti sempre unici e esclusivi.

A custom approach to the bathroom project for a timeless collection, a journey through versatile solutions based on maximum functionality. A collection characterised by the exclusivity of the materials, by the balance of the volumes and by in-depth chromatic research; an exclusive proposal, with sophisticated details, where the work quality, the rich offer of solutions, and the ability to interpret the needs of different contexts allow a reinterpretation of the bathroom tradition through a new language: a perfect synthesis of style and design. Between memory and modernity, technology and craftsmanship and between versatile compositions and formal research, the Noorth proposal is developed into 8 collections where simple lines are enhanced by the unique textures of marble and veneers, the new and exclusive palette of lacquers, the absolute transparency of the crystals and the shine of metals. A careful study of materials, colour combinations and raw materials, allows the realisation of complete and defined projects, offering unique and exclusive products.

Une approche vestimentaire au projet de salle de bain pour une collection éternelle, un voyage à travers des solutions polyvalentes basées sur une fonctionnalité maximale. Une collection caractérisée par l'exclusivité des matériaux, par l'équilibre des volumes et par des recherches chromatiques approfondies; une proposition exclusive, avec des détails sophistiqués, où la qualité du travail, la riche offre de solutions et la capacité d'interpréter les besoins de différents contextes permettent de réinterpréter la tradition de la salle de bains à travers un nouveau langage: une synthèse parfaite





## Marble, veneer and lacquered colours.

de style et projet. Entre mémoire et modernité, technologie et artisanat et entre polyvalence compositionnelle et recherche formelle, la proposition Noorth se charpente en 8 collections dans lesquelles les traits essentiels sont mis en valeur par les textures uniques du marbre et des essences, par la nouvelle et exclusive palette de laqués, par la transparence absolue des cristaux et la brillance des métaux. Une étude profonde des matériaux, des combinaisons de couleurs et des matières premières, permet la réalisation de projets complets et définis, en offrant des produits uniques et exclusifs. Noorth est de nos jours une réalité bien définie, le résultat concret d'une vision précise, un nouveau projet qui nous stimule et nous remplit d'enthousiasme.

Dank einer individuellen Herangehensweise an das Projekt Badezimmer ist eine zeitlose Kollektion entstanden, die von Vielseitigkeit und maximaler Funktionalität geprägt ist. Eine Kollektion, die sich durch die Exklusivität der Materialien und das Gleichgewicht der Elemente auszeichnet und das Ergebnis umfassender Farbforschungen ist. Ein exklusives Angebot voller raffinierter Details, wo die Qualität der Verarbeitung, die vielfältigen Lösungen und die Fähigkeit, den Anforderungen verschiedener Kontexte gerecht zu werden, das traditionelle Bild des Badezimmers neu interpretieren: die perfekte Vereinigung von Stil und Projekt. Unvergängliche Werte und Moderne, Technologie und Handwerk, kompositorische Vielseitigkeit und Formsuche – das Angebot von Noorth präsentiert sich in 8 Kollektionen, wo die Essenz der Linien durch die unvergleichlichen Texturen von Marmor und Holz, durch die neue, exklusive Palette von Lackflächen, durch die absolute Transparenz von Glas und den Glanz von Metall hervorgehoben wird. Die exakte Arbeit mit Materialien, Farbzusammenstellungen und Rohstoffen ermöglicht die Ausführung umfassender, in jeder Hinsicht definierter Projekte. Das Ergebnis? Einzigartige, exklusive Produkte.

Почти индивидуальный подход к проекту ванной комнаты для создания коллекции, не знающей времени, путешествие в мир универсальных решений, отмеченных максимальной функциональностью. Коллекция, характеризующаяся эксклюзивностью материалов, гармонией объемов и тщательным поиском цветовых оттенков; эксклюзивное предложение с изысканными деталями, среди которых качество обработки, большой выбор решений и способность отвечать требованиям различных контекстов – всё это позволяет заново выразить традиционный образ ванной комнаты современным языком: отличный синтез стиля и проекта. Между памятью и современностью, технологией и ручным мастерством,

универсальностью композиции и поиском форм – предложение Noorth представлено 8 коллекциями, в которых минимализм линий подчеркивается неповторимой текстурой мрамора и древесного шпона, а также новой и эксклюзивной палитрой лакированных отделок, абсолютной прозрачностью хрусталя и блеском металлических деталей. Тщательное изучение материалов, сочетания цветов и сырьевых материалов позволило создать завершенные и определенные проекты с предложением всегда уникальной и эксклюзивной продукции.

## MISSION

Abbiamo scelto il nome Noorth perché evocativo di un'idea di freschezza e di semplicità che, variamente modulata, si ritrova unanimemente percepita e condivisa in culture differenti. In questa ottica, le radici italiane e il forte legame con la tradizione che contraddistinguono la nostra realtà sono considerati qualità fondamentali da valorizzare con sensibilità e linguaggi espressivi diversi. Una visione che vogliamo tradurre in una collezione per l'arredo dell'ambiente bagno senza tempo e quindi davvero contemporanea, un insieme ragionato di precisi strumenti di progettazione affiancati da soluzioni stilistiche dal forte valore evocativo. Una proposta concreta, definita e in continua evoluzione, basata su scelte tecniche rigorose del centro ricerche Noorth stimulate da un dialogo continuo con la creatività del migliore design.

## IL PROGETTO

Dalla definizione dell'architettura alla caratterizzazione espressiva: il centro ricerche Noorth lavora con il preciso obiettivo di raggiungere proposte concrete, pensate per ambienti bagno reali, in grado di rispondere alle diverse esigenze progettuali con soluzioni sempre funzionali e stilisticamente coerenti. Dai sistemi di contenitori componibili come Puro e Sintesi a quelli più definiti come Zenit e One, fino a soluzioni fortemente iconiche come Touch; da progetti dal forte valore evocativo come Roma e Azuma a proposte dal valore più tecnico come Fjord: la collezione Noorth è un grande sistema integrato che prevede una straordinaria offerta di accessori e complementi, risultato di un'attenta cura degli aspetti tecnici e formali.

## I MATERIALI

Il bagno è un ambiente particolare, in cui le esigenze tecniche legate alla presenza dell'acqua, del vapore e di sostanze per la cura del corpo sono affiancate da un diffuso desiderio di naturalità. Questa consapevolezza ci porta a dedicare una ricerca specifica verso la scelta dei materiali: da quelli naturali come pietre, legni, quarzite e vetri a quelli dal valore più tecnico come le resine e l'alluminio. Selezionati con cura in base alle specifiche proprietà, i materiali Noorth dialogano con armonia nel rispetto di un preciso obiettivo: fornire soluzioni stilisticamente diverse e nello stesso tempo coordinate da una visione comune, basata su una qualità estetica e d'immagine

senza tempo. La proposta viene affiancata dalle laccature, opache o lucide, ottenute con l'utilizzo di vernici all'acqua di ultima generazione, nel rispetto dei più rigorosi principi di sostenibilità.

## MISSION

We chose the name Noorth because it evokes a freshness and simplicity that, in their various forms, are understood and shared by different cultures. In our interpretation, the Italian roots and the strong connection with tradition that are our trademark are considered fundamental qualities, worthy of being highlighted with sensitivity and various means of expression. It's a vision that we want to translate in a timeless and thus truly contemporary collection of bathroom fixtures, a whole created with precise design tools combined with strongly evocative stylistic solutions. A concrete, well-defined proposal in constant evolution, based on rigorous technical choices of the Noorth research centre, stimulated by a constant dialogue with the creativity of the best designers.

## THE DESIGN

From the definition of architecture to expressive characterisation: the Noorth research centre works with the precise goal of reaching concrete proposals, for real bathrooms, able to offer always functional and stylistically coherent solutions to various design needs. From modular container systems, like Puro and Sintesi, Zenit and One, all the way to iconic solutions, like Touch; from highly evocative designs, like Roma and Azuma, to more technical suggestions, like Fjord: the Noorth collection is a big integrated system that offers an extraordinary range of accessories, the result of meticulous attention to every technical and formal aspect.

## THE MATERIALS

A bathroom is a particular environment, in which technical requirements related to the presence of water, vapour and body care substances must be combined with a universal desire for simplicity. This awareness has led us to perform specific research in the choice of materials: we opted for both natural types, like stone, wood and glass, and for more technical forms, such as resins and aluminium. Selected with care based on their specific properties, the materials used by Noorth are combined harmoniously towards a

precise goal: to provide stylistically diverse solutions that are driven by a common vision, based on quality of aesthetics and a timeless image. The range is combined with veneers, be they opaque or transparent, obtained with the use of the most technologically advanced varnishes.

## MISSION

Nous avons choisi le nom Noorth car il donne une idée de fraîcheur et de simplicité qui, modulée de diverses manières, est perçue par tout le monde et partagée par des cultures différentes. Dans cet esprit, les racines italiennes et le lien étroit avec la tradition qui caractérisent notre réalité sont considérés des qualités fondamentales qui doivent être mises en valeur avec beaucoup de sensibilité et des langages expressifs différents. C'est une vision que nous voulons concrétiser dans une collection d'ameublement de salle de bain intemporelle et donc extrêmement actuelle, un ensemble raisonné d'instruments de conception précis secondés par des solutions stylistiques d'une forte valeur évocatrice. Une proposition concrète, définie et en évolution constante qui se base sur les choix techniques rigoureux du centre de recherches de Noorth stimulés par le dialogue constant avec la créativité du meilleur design.

## LE PROJET

De la définition de l'architecture à la caractérisation expressive : le centre de recherches Noorth travaille en visant un objectif précis, celui d'atteindre des propositions concrètes, conçues pour des salles de bain réelles, en mesure de répondre aux différentes exigences de conception avec des solutions toujours fonctionnelles et cohérentes stylistiquement. Des systèmes de rangement modulaires comme Puro et Sintesi, Zenit et One, jusqu'aux solutions plus emblématiques comme Touch; des projets d'une forte valeur évocatrice comme Roma et Azuma jusqu'à des propositions avec une valeur plus technique comme Fjord: la collection Noorth est un grand système intégré qui offre des accessoires et des compléments extraordinaires qui sont le résultat du plus grand soin des aspects techniques et formels.

## LES MATÉRIAUX

La salle de bain est un endroit particulier, où les exigences techniques liées à la

présence de l'eau, de la vapeur et des produits pour les soins corporels se combinent à la recherche du naturel. Cette prise de conscience nous porte à choisir spécifiquement des matériaux: de ceux naturels comme pierre, bois et verre à ceux avec une valeur plus technique comme les résines et l'aluminium. Les matériaux Noorth ont été sélectionnés avec soin par rapport à leurs propriétés spécifiques, ils se combinent harmonieusement et dans un seul objectif: fournir des solutions stylistiquement différentes et coordonnées en même temps par une vision commune qui se base sur une qualité esthétique et d'image intemporelle. Cette proposition intègre également des laquages, mats ou brillants, réalisés en utilisant des peintures de dernière génération.

## MISSION

Wir haben den Namen Noorth ausgewählt, weil er an Frische und Natürlichkeit erinnert, die, wenn sie auf unterschiedliche Weise koordiniert wird, von verschiedenen Kulturen übereinstimmend wahrgenommen und gemeinsam geteilt wird. In diesem Sinne gelten die italienischen Wurzeln und die starke Verbindung mit der Tradition, die unser Unternehmen auszeichnet, als grundlegende Eigenschaften, die durch unterschiedliche Wahrnehmungsweisen und ausdrucksstarke Formen ergänzt werden. Eine Vision, die wir in eine zeitlose und damit wirklich zeitgemäße Kollektion für die Einrichtung des Badezimmers umsetzen wollen, eine durchdachte Kombination präziser Designwerkzeuge, begleitet von stilistischen Lösungen mit einer starken Aussagekraft. Ein konkretes, klares und sich ständig weiterentwickelndes Angebot, das auf strengen technischen Entscheidungen des Forschungszentrums von Noorth basiert, die durch einen kontinuierlichen Dialog mit der Kreativität des besten Designs angeregt werden.

## DAS PROJEKT

Von der Festlegung der Struktur bis zur ausdrucksstarken Gestaltung: Das präzise Bestreben des Forschungszentrums von Noorth besteht darin, konkrete Vorschläge zu erarbeiten, die für echte Bäder konzipiert sind und mit stets funktionellen und stilistisch stimmigen Lösungen auf die unterschiedlichen Designanforderungen reagieren können. Von modularen Behältnissen wie Puro und Sintesi, Zenit und One bis hin zu ikonischen Lösungen wie Touch; von stimmungsvollen Projekten wie Roma und Azuma bis hin zu eher

technischen Vorschlägen wie Fjord: Die Kollektion Noorth ist ein großes integriertes System mit einem außergewöhnlichen Angebot an Zubehör und Accessoires, das Ergebnis einer sorgfältiger Berücksichtigung der technischen und formellen Aspekte.

## DIE MATERIALIEN

Das Bad ist eine besondere Umgebung, in der die technischen Anforderungen, die an das Vorhandensein von Wasser, Dampf und Substanzen für die Körperpflege gebunden sind, von einem weit verbreiteten Wunsch nach Natürlichkeit begleitet werden. Dieses Bewusstsein führt uns zu einer gezielten Recherche bei der Materialauswahl: von natürlichen Materialien wie Stein, Holz und Glas bis hin zu technisch wertvolleren wie Harzen und Aluminium. Sorgfältig nach ihren spezifischen Eigenschaften ausgewählt, stehen die Materialien von Noorth im Einklang mit einem präzisen Ziel: stilistisch unterschiedliche Lösungen anzubieten und gleichzeitig von einer gemeinsamen Vision koordiniert zu werden, die auf einer zeitlosen Qualität der Ästhetik und des Images basiert. Das Angebot wird von matten oder glänzenden Lackoberflächen begleitet, die unter Verwendung der neuesten Generation von Farben hergestellt werden.

## МИССИЯ

Мы выбрали название Noorth, потому что оно ассоциируется с идеей свежести и простоты, которая при различной модуляции находит единый отклик в различных культурах. Итальянские корни и сильная связь с традициями отличают нашу компанию и представляют собой фундаментальные ценности, которые мы стараемся подчеркивать, проявляя особую чувствительность и используя различные способы выражения. Мы намерены воплотить наше видение в коллекцию всегда модной, а значит по настоящему современной мебели для ванных комнат. Это продуманная совокупность конкретных проектных инструментов в сочетании со своеобразными стилистическими решениями. Конкретное, четко определенное и постоянно совершенствующееся предложение, основанное на строжайших технических решениях центра исследований Noorth, создаваемых в результате непрерывного взаимодействия с дизайнерской креативностью.

## ПРОЕКТ

От определения архитектуры до выразительности характера: центр исследований Noorth ставит себе целью создавать конкретные решения для реальных ванных комнат, которые могли бы отвечать различным проектным потребностям и всегда отличались бы функциональностью и стилистической последовательностью. От komponуемых шкафчиков, таких как Puro и Sintesi, Zenit и One, до по настоящему легендарных решений, таких как Touch; от крайне своеобразных проектов Roma и Azuma до наиболее технических решений, таких как Fjord: коллекция Noorth – это интегрированная обширная коллекция, включающая необычные аксессуары и предметы интерьера, являющаяся результатом тщательной разработки технических и формальных аспектов.

## МАТЕРИАЛЫ

Ванная комната – это особое помещение, в котором технические потребности, связанные с наличием воды, пара и средств по уходу за телом, пересекаются с распространенным стремлением к натуральности. Осознание этого заставило нас обратить особое внимание на выбор материалов, начиная от натуральных, таких как камень, древесина и стекло, и заканчивая наиболее техническими, такими как смолы и алюминий. Материалы коллекции Noorth, тщательно отобранные с учетом особых характеристик, способствуют гармоничному достижению конкретной цели: создания стилистически разных, но в то же время сочетающихся между собой решений благодаря общему видению, основанному на неподвластной времени эстетике. Решение завершает матовая или глянцевая лакировка с использованием лакокрасочных покрытий последнего поколения.

# Compositions

1



Fjord Collection	15
Puro Collection	63
Zenit Collection	119
Azuma Collection	149
Roma Collection	171
Touch Collection	199
Sintesi Collection	215
One Collection	269

# Fjord Collection

design by Giuseppe Bavuso

Raggiungere nuovi standard estetici e funzionali, garantire flessibilità progettuale e semplicità di montaggio: questi gli obiettivi del progetto Fjord. Un sistema componibile ad alte prestazioni basato su una struttura metallica affiancata da una serie di contenitori in essenza, vani a giorno, cassettiere, ripiani, piani lavabo, specchiere e mensole attrezzate. Una serie di componenti arricchita da un insieme coordinato di finiture esclusive, dai metalli alle pietre, dai vetri alle essenze fino ai laccati, che permette la definizione di soluzioni estetiche inedite.

Achieving new aesthetic and functional standards, ensuring design flexibility and easy assembly: these are the aims of the Fjord project. A high-performance modular system based on a metal frame, flanked by a series of veneer bases, open-fronted units, chests of drawers, shelves, washbasin tops, mirrors and wall-mounted shelves. New aesthetic solutions are defined by using a series of components with a matching range of exclusive finishes, from metal to stone, from glass to veneer finishes and lacquers.

Les objectifs du projet Fjord sont atteindre de nouveaux standards esthétiques et fonctionnels, garantir une souplesse de conception et la simplicité du montage. Un système modulable aux performances de haut niveau qui se base sur une structure métallique associée à une série d'éléments de rangement en essence, niches ouvertes, commodes, étagères, plans pour vasques, miroirs et étagères aménagées. Une série d'éléments enrichie par un système coordonné de finitions exclusives qui vont des métaux aux pierres, en passant par les verres, les essences et les laques, ce qui permet de définir des solutions esthétiques innovantes.

Die Erreichung neuer ästhetischer und funktioneller Maßstäbe, die Gewährleistung bester Designflexibilität und Montagefreundlichkeit: Das sind die Ziele des Projekts Fjord. Ein leistungsstarkes modulares System auf der Basis einer Metallstruktur, ergänzt von einer Reihe von Behältern aus Holz, offenen Fächern, Schubladenblöcken, Regalen, Waschtischplatten, Spiegeln und Ablageflächen. Eine Reihe von Komponenten, verfeinert durch ein harmonisches Zusammenspiel von exklusiven Oberflächen, von Metallen bis zu Steinen, von Glas über Holz bis hin zu Lackoberflächen, mit denen neue ästhetische Lösungen geschaffen werden können.

Достижение новых эстетических и функциональных стандартов, обеспечение гибкости дизайна и простоты сборки – вот цели проекта Fjord. Высококачественная модульная система, основанная на металлической конструкции с серией шкафчиков в шпоне, открытых элементов, ящиков, полок, столешниц, зеркал и укомплектованных аксессуарами полок. Серия компонентов, обогащенная координированным набором эксклюзивных отделок: от металлов до камней, от стекла до лакированных поверхностей, что позволяет создавать определенные уникальные эстетические решения.

Quarzo  
 Rovere Nero  
 Fumé  
 Cristalplant  
 235,2 (1,2 + 90 + 72 + 72) x 33,5 x 51,2 cm  
 92 5/8" (1/2" + 35 3/5" + 28 3/8" + 28 3/8") x 13 1/4" x 20 1/8"

Lavabo in appoggio Step 63.12 in Cristalplant. Top in Rovere Nero. Elemento a giorno con struttura in alluminio laccato Quarzo e ripiano in vetro fumè. Basi con cassetto in Rovere Nero e vano a giorno. Specchiera Ekos H con retroilluminazione a LED quattro lati e illuminazione a LED un lato superiore interno, profilo in alluminio laccato Quarzo. Mensole Ljos in alluminio laccato Quarzo, complete di accessori, con e senza retroilluminazione a LED. Sanitari Senna in ceramica opaca. Rubinetteria Flow in acciaio inox satinato con cartuccia tradizionale.

Step 63.12 Cristalplant sit-on washbasin. Rovere Nero top. Open unit with Quarzo finish lacquered aluminium frame and smoked glass shelf. Base units with Rovere Nero drawer and open shelving. Ekos H mirror with all-round LED backlight and single-sided interior upper LED lighting, Quarzo finish lacquered aluminium profile. Ljos shelves in Quarzo finish lacquered aluminium, complete with accessories, with and without LED backlight. Senna matt ceramic sanitary ware. Flow taps in brushed stainless steel, with traditional cartridge.

Lavabo à poser Step 63.12 en Cristalplant. Plan en Rovere Nero. Élément à jour avec structure en aluminium laqué Quarzo et étagère en verre fumé. Bases avec tiroir en Rovere Nero et élément à jour. Miroir Ekos H avec rétroéclairage à LED quatre côtés et éclairage à LED un côté supérieur interne, profil en aluminium laqué Quarzo. Étagères Ljos en aluminium laqué Quarzo, pourvues d'accessoires, avec et sans rétroéclairage à LED. Sanitaires Senna en céramique mate. Robinetterie Flow en acier inox satiné avec cartouche traditionnelle.

Waschbecken mit Auflage Step 63.12 aus Cristalplant. Platte aus Rovere im Farbton Nero. Offenes Element mit Aluminiumstruktur mit Lackoberfläche im Farbton Quarzo und Ablage aus Glas im Farbton Fumé. Unterbauten mit Schublade aus Rovere im Farbton Nero und offenem Fach. Spiegel Ekos H mit vierseitiger LED-Hintergrundbeleuchtung und LED-Beleuchtung im oberen Bereich innen, Profil aus Aluminium mit Lackoberfläche im Farbton Quarzo. Ablageflächen Ljos aus Aluminium mit Lackoberfläche im Farbton Quarzo, komplett mit Zubehör, mit und ohne LED-Hintergrundbeleuchtung. Sanitäranlagen Senna aus matter Keramik. Wasserhähne Flow aus satiniertem Edelstahl mit traditioneller Kartusche.

Накладная раковина Step 63.12 из Cristalplant. Столешница из дуба Rovere Nero. Открытый элемент с алюминиевой лакированной конструкцией Quarzo и полкой из дымчатого стекла. Тумбы с ящиком из дуба Rovere Nero и открытым элементом. Зеркало Ekos H с четырехсторонней светодиодной подсветкой и светодиодной подсветкой с верхней внутренней стороны, профиль из лакированного алюминия Quarzo. Полки Ljos из лакированного алюминия Quarzo в комплекте с аксессуарами, со светодиодной подсветкой и без нее. Сантехника Senna из матовой керамики. Смесители Flow из satinированной нержавеющей стали с традиционным картриджем.



























FJORD 19.02

Titanio  
 Noce Canaletto  
 Ceramilux matt  
 Cristalplant  
 181,2 (1,2 + 90 + 90) x 33,5 x 51,2 cm  
 71 3/8" (1/2" + 35 3/8" + 35 3/8") x 13 1/4" x 20 1/8"

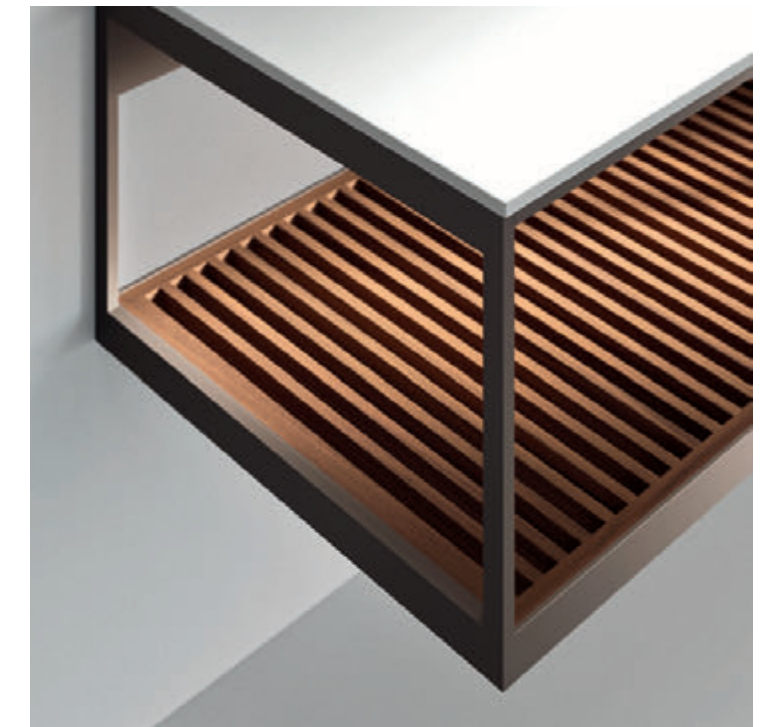

Lavabo in appoggio Basic R58 in Ceramilux matt. Top in Cristalplant. Elementi a giorno con struttura in alluminio laccato Titanio e listelli in Noce Canaletto. Specchiera Ekos H con illuminazione a LED un lato orizzontale interno e profilo in alluminio laccato Titanio. Rubinetteria Flow in acciaio inox satinato con cartuccia tradizionale. | Basic R58 matt Ceramilux sit-on washbasin, Cristalplant Top. Open units with Titanio finish lacquered aluminium frame and Canaletto Noce strips. Ekos H mirror, single-sided interior horizontal LED lighting and Titanio finish lacquered aluminium profile. Flow taps in brushed stainless steel, with traditional cartridge. | Lavabo à poser Basic R58 en Ceramilux mat Plan en Cristalplant. Éléments à jour avec structure en aluminium laqué Titanio et plinthes en Noce Canaletto. Miroir Ekos H avec éclairage à LED un côté horizontal interne et profil en aluminium laqué Titanio. Robinetterie Flow en acier inox satiné avec cartouche traditionnelle. | Aufgewaschbecken Basic R58 aus Ceramilux Matt Platte aus Cristalplant. Offene Elemente mit Aluminiumstruktur mit Lackoberfläche im Farbton Titanio und Leisten aus Noce Canaletto. Spiegel Ekos H mit LED-Beleuchtung auf einer horizontalen Innenseite und Profil aus Aluminium mit Lackoberfläche im Farbton Titanio. Wasserhähne Flow aus satiniertem Edelstahl mit traditioneller Kartusche. | Накладная раковина Basic R58 из Ceramilux matt Столешница из Cristalplant. Открытые элементы с лакированной алюминиевой конструкцией Titanio и рейками из ореха Noce Canaletto. Зеркало Ekos H со светодиодной подсветкой с внутренней горизонтальной стороны и профилем из лакированного алюминия Titanio. Смесители Flow из сатиновой нержавеющей стали с традиционным картриджем.

Ambra

Noce Canaletto

Calacatta Oro

218,4 (1,2 + 54 + 36 + 36 + 1,2 + 90) x 33,5 x 51,2 cm

86" (1/2" + 21 1/4" + 14 1/8" + 14 1/8" + 1/2" + 35 3/8") x 13 1/4" x 20 1/8"

Top integrato Horizon in marmo Calacatta Oro. Elementi a giorno con struttura in alluminio laccato Ambra e listelli in Noce Canaletto. Basi con due cassetti con incastro a pettine in Noce Canaletto. Specchiera Ekos H Plus con illuminazione a LED tre lati interni, profilo e mensola inferiore in alluminio laccato Ambra. Mensole Ljos in alluminio laccato Ambra, complete di accessori e retroilluminazione a LED. Sanitari Senna in ceramica opaca. Rubinetteria Flow in acciaio inox satinato con cartuccia tradizionale.

Horizon built-in top made of Calacatta Gold marble. Open units with Ambra finish lacquered aluminium frame and Canaletto Noce strips. Canaletto Noce base units, two drawers with finger joint system. Ekos H Plus mirror, three-sided interior LED lighting, Ambra finish lacquered aluminium profile and lower shelf. Ljos shelves in Ambra finish lacquered aluminium, complete with accessories and LED backlight. Senna matt ceramic sanitary ware. Flow taps in brushed stainless steel, with traditional cartridge.

Plan intégré Horizon en marbre Calacatta Oro. Éléments à jour avec structure en aluminium laqué Ambra et plinthes en Noce Canaletto. Bases avec deux tiroirs avec assemblage à entures en Noce Canaletto. Miroir Ekos H Plus avec éclairage à LED trois côtés internes, profil et étagère inférieure en aluminium laqué Ambra. Étagères Ljos en aluminium laqué Ambra, pourvues d'accessoires et rétroéclairage à LED. Sanitaires Senna en céramique mate. Robinetterie Flow en acier inox satiné avec cartouche traditionnelle.

Integrierte Platte Horizon aus Marmor im Farbton Calacatta Oro. Offene Elemente mit einer Aluminiumstruktur mit Lackoberfläche im Farbton Ambra und Leisten aus Noce Canaletto. Unterbau mit zwei Schubladen mit Schwalbenschwanzverbindung aus Noce Canaletto. Spiegel Ekos H Plus mit LED-Beleuchtung auf den drei Innenseiten. Profil und untere Ablagefläche aus Aluminium mit Lackoberfläche im Farbton Ambra. Ablageflächen Ljos aus Aluminium mit Lackoberfläche im Farbton Ambra, komplett mit Zubehör und LED-Hintergrundbeleuchtung. Sanitäranlagen Senna aus matter Keramik. Wasserhähne Flow aus satiniertem Edelstahl mit traditioneller Kartusche.

Интегрированная столешница Horizon из мрамора Calacatta Oro. Открытые элементы с лакированной алюминиевой конструкцией Ambra и рейками из ореха Noce Canaletto. Тумбы с двумя ящиками с зубчатым соединением из ореха Noce Canaletto. Зеркало Ekos H Plus со светодиодной подсветкой с трех внутренних сторон, профиль и нижняя полка из лакированного алюминия Ambra. Полки Ljos из лакированного алюминия Ambra в комплекте с аксессуарами и светодиодной подсветкой. Сантехника Senna из матовой керамики. Смесители Flow из satinированной нержавеющей стали с традиционным картриджем.









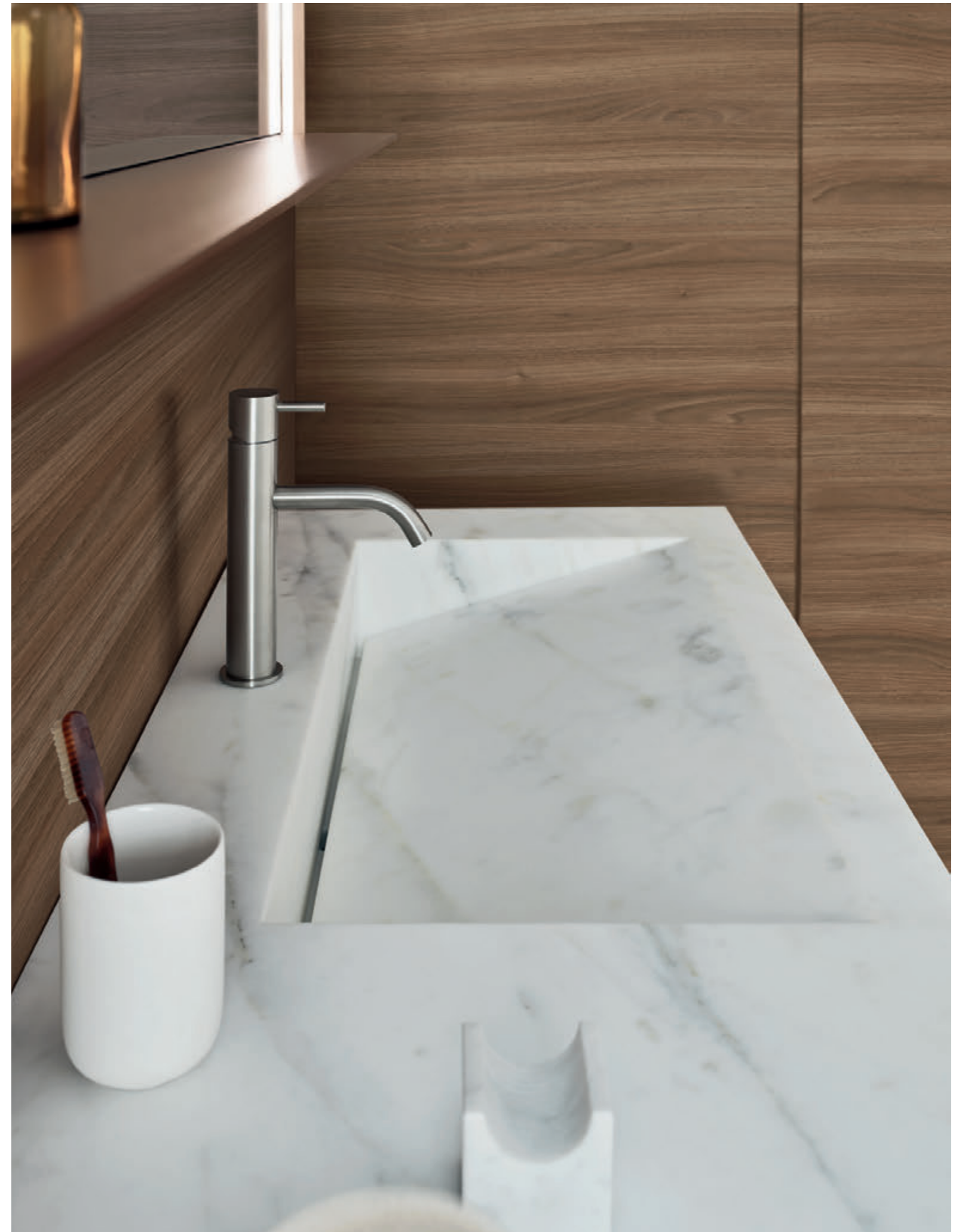



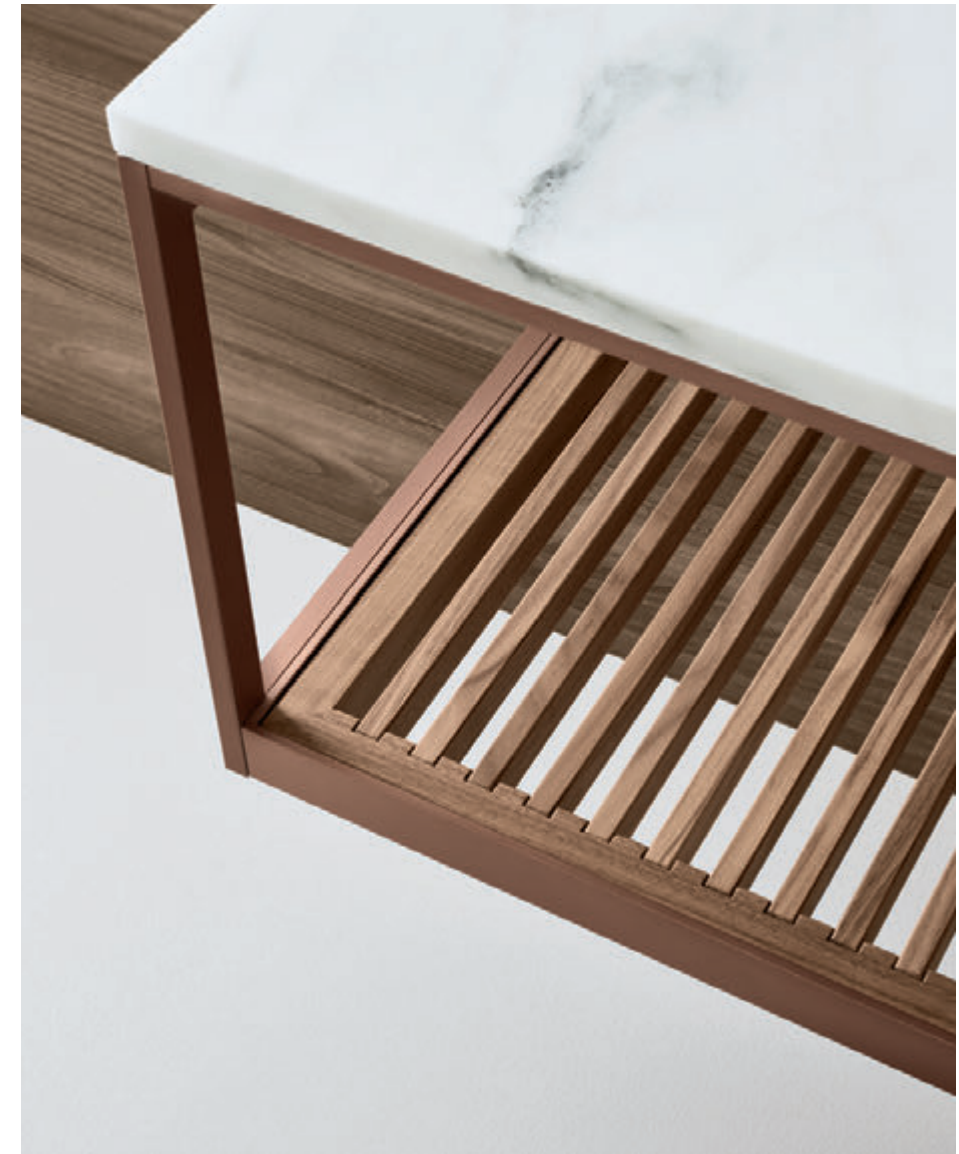







FJORD 19.04

Basalto

Castoro

Fumé

Milltek Solid

181,2 (1,2 + 108 + 72) x 33,5 x 51,2 cm

71 3/8" (1/2" + 42 1/2" + 28 3/8") x 13 1/4" x 20 1/8"



Top integrato Horizon in Milltek Solid. Elemento a giorno con struttura in alluminio laccato Basalto e ripiano in vetro fumè. Base con due cassette in laccato Castoro opaco. Specchiera Ekos V con illuminazione a LED due lati verticali interni e profilo in alluminio laccato Basalto. Mensole Ljos in alluminio laccato Basalto, complete di accessori e retroilluminazione a LED. Rubinetteria Flow in acciaio inox finitura PVD nero opaco con cartuccia tradizionale. I Horizon Milltek Solid built-in top. Open unit with Basalto finish lacquered aluminium frame and smoked glass shelf. Base unit with two drawers in matt Castoro lacquered. Ekos V mirror, double-sided interior vertical LED lighting and Basalto finish lacquered aluminium profile. Ljos shelves in Basalto finish lacquered aluminium, complete with accessories and LED backlight. Flow taps in stainless steel, matt black PVD finish, with traditional cartridge. I Plan intégré Horizon en Milltek Solid. Élément à jour avec structure en aluminium laqué Basalto et plan en verre fumé. Base avec deux tiroirs en laqué Castoro mat. Miroir Ekos V avec éclairage à LED deux côté verticaux internes et profil en aluminium laqué Basalto. Étagères Ljos en aluminium laqué Basalto, pourvues d'accessoires et rétroéclairage à LED. Robinetterie Flow en acier inox finition PVD noir mat avec cartouche traditionnelle. I Integrierte Platte Horizon aus Milltek Solid. Offenes Element mit Aluminiumstruktur mit Lackoberfläche im Farbton Basalto und Ablage aus Glas im Farbton Fumé. Unterbau mit zwei Schubladen und Lackoberfläche im Farbton Castoro Matt. Spiegel Ekos V mit LED-Beleuchtung auf den beiden vertikalen Innenseiten und Aluminiumprofil mit Lackoberfläche im Farbton Basalto. Ablageflächen Ljos aus Aluminium mit Lackoberfläche im Farbton Basalto, komplett mit Zubehör und LED-Hintergrundbeleuchtung. Wasserhähne Flow aus Edelstahl Oberflächenausführung mit mattschwarzer PVD-Beschichtung und traditional Kartusche. I Интегрированная столешница Horizon из Milltek Solid. Открытый элемент с алюминиевой лакированной конструкцией Basalto и полкой из дымчатого стекла. Тумба с двумя ящиками в матовом лаке Castoro и открытым элементом. Зеркало Ekos V со светодиодной подсветкой с двух внутренних вертикальных сторон и лакированным алюминиевым профилем Basalto. Полки Ljos из лакированного алюминия Basalto в комплекте с аксессуарами и светодиодной подсветкой. Смесители Flow из нержавеющей стали с черной матовой отделкой PVD с традиционным картриджем.



Platino  
 Milltek Solid  
 Rovere Mezza Fiamma  
 253,2 (1,2 + 90 + 72 + 90) x 33,5 x 51,2 cm  
 99 5/8" (1/2" + 35 3/8" + 28 3/8" + 35 3/8") x 13 1/4" x 20 1/8"

Top integrato Finn in Milltek Solid attrezzato con vassoi portaoggetti in Rovere Mezza Fiamma. Elementi a giorno con struttura e ripiano in alluminio bugnato laccato Platino. Base con cassetto e vano a giorno in laccato Platino. Specchiera Ekos V con retroilluminazione a LED quattro lati e illuminazione a LED due lati verticali interni, profilo in alluminio laccato Platino. Mensole Ljos in alluminio laccato Platino, complete di accessori e retroilluminazione a LED. Rubinetteria Flow in acciaio inox satinato con cartuccia progressiva.

Finn Milltek Solid built-in top fitted with Rovere Mezza Fiamma storage trays. Open units with frame and shelf made of Quarzo finish embossed aluminium. Base unit with Platino finish lacquered drawer and open shelving. Ekos V mirror with all-round LED backlight and double-sided interior vertical LED lighting. Platino finish lacquered aluminium profile. Ljos shelves in Platino finish lacquered aluminium, complete with accessories and LED backlight. Flow taps in brushed stainless steel, with progressive cartridge.

Plan intégré Finn en Milltek Solid équipé avec plateaux porte-objets en Rovere Mezza Fiamma. Eléments à jour avec structure et étagère en aluminium à larmes laqué Platino. Base avec tiroir et élément à jour en laqué Platino. Miroir Ekos V avec rétroéclairage à LED quatre côtés et éclairage à LED deux côtés verticaux internes, profil en aluminium laqué Platino. Étagères Ljos en aluminium laqué Platino, pourvues d'accessoires et rétroéclairage à LED. Robinetterie Flow en acier inox satiné avec cartouche progressive.

Integrierte Platte Finn aus Milltek Solid ausgestattet mit Becken mit Auflage aus Rovere im Farbton Mezza Fiamma. Offene Elemente mit Struktur und Ablage aus bossiertem Aluminium mit Lackoberfläche im Farbton Platino. Unterbau mit Schublade und offenem Fach mit Lackoberfläche im Farbton Platino. Spiegel Ekos H mit vierseitiger LED-Hintergrundbeleuchtung und LED-Beleuchtung auf den beiden vertikalen Innenseiten, Profil aus Aluminium mit Lackoberfläche im Farbton Platino. Ablageflächen Ljos aus Aluminium mit Lackoberfläche im Farbton Platino, komplett mit Zubehör und LED-Hintergrundbeleuchtung. Wasserhähne Flow aus satiniertem Edelstahl mit progressiver Kartusche.

Интегрированная столешница Finn из Milltek Solid с поддонами из дуба Rovere Mezza fiamma. Открытые элементы с конструкцией и полкой из лакированного рифленого алюминия Platino Тумба с ящиком и лакированным открытым элементом Platino Зеркало Ekos V с четырехсторонней светодиодной подсветкой и светодиодной подсветкой с двух вертикальных внутренних сторон, с профилем из лакированного алюминия Platino. Полки Ljos из лакированного алюминия Platino в комплекте с аксессуарами и светодиодной подсветкой. Смесители Flow из satinированной нержавеющей стали с прогрессивным картриджем.























## Talking with *Giuseppe Bavuso*



Architetto e designer vive e lavora a Seregno, Lombardia. Nei suoi progetti coniuga il rigore del segno quasi minimalista con una grande ricerca tecnica, attraverso il sapiente uso di materiali tecnologici ed innovativi.

Architect and designer, he lives and works in Seregno, Lombardy. In his projects, he combines a rigorous, somewhat minimalist style with thorough technical research, thanks to the masterful use of technological and innovative materials.

“With all the hustle and bustle of everyday life, we need a private space where we can regenerate ourselves both physically and mentally, a place where we can feel good.”

*L'arredo bagno è per te un ambito di progetto inesplorato. Quali sono le motivazioni che ti hanno spinto ad affrontare questa esperienza?*

Nel mio, come in tutti i lavori basati su un impegno collettivo, la condivisione degli obiettivi e il feeling con le persone con cui si lavora sono presupposti fondamentali. Di Noorth mi è subito piaciuto il progetto aziendale, la volontà di sperimentare nuove strade associata ad una grande competenza che mi ha permesso di sentirmi immediatamente a mio agio. Inoltre l'ambiente bagno ha subito nel tempo una trasformazione profonda, sia dal punto di vista tecnico che delle abitudini. Una dimensione molto stimolante, senz'altro ideale per un designer.

*Che valore ha l'ambiente bagno nella casa contemporanea?*

La cura del corpo ha un'importanza sempre maggiore. La frenesia della vita quotidiana richiede uno spazio privato dove rigenerarsi sia sul piano fisico che mentale, un luogo dove sentirsi bene, per godere di momenti di relax, dedicati al benessere, in un ambiente accogliente e rilassante. Questa esigenza, relativamente recente, ha stimolato la ricerca di soluzioni che vanno oltre l'aspetto funzionale e riguardano anche la sfera emotiva personale. Con Fjord abbiamo cercato di suggerire una interpretazione stilistica nuova, in cui materiali naturali come il legno e la pietra si innestano sul frame rigoroso del telaio in alluminio. Un sistema flessibile, da comporre liberamente rispetto alle proprie personali esigenze, ma nello stesso tempo in grado di presentarsi come un mobile prezioso, ricco di dettagli originali e finiture ricercate.

*Bathroom furnishings are an unexplored project area for you. What prompted you to tackle this project?*

In my job, as in all jobs based on team effort, sharing goals and having good chemistry with the people you work with are basic prerequisites. I was instantly intrigued by Noorth's corporate project, the desire to explore new directions combined with a high level of expertise, which made me feel immediately at ease. Furthermore, the bathroom has undergone a profound transformation over time, both from a technical point of view and in terms of habits. A very stimulating dimension, certainly ideal for a designer.

*How much importance is attributed to the bathroom in contemporary homes?*

Taking care of our bodies is becoming increasingly important. With all the hustle and bustle of everyday life, we need a private space where we can regenerate ourselves both physically and mentally, a place where we can feel good, enjoy moments of relaxation and focus on our well-being, in a welcoming and relaxing environment. This need, which is relatively recent, has stimulated the search for solutions that go beyond the functional aspect and also touch on the personal emotional sphere. With Fjord we tried to suggest a new stylistic interpretation, where natural materials, such as wood and stone, are grafted onto the rigorous frame of the aluminium chassis. A flexible system, to be composed freely with respect to one's personal needs, but at the same time able to serve as a precious piece of furniture, rich in original details and refined finishes.

*Nell'arredo della casa, come in altri ambiti merceologici, stiamo assistendo ad una evidente evoluzione del concetto di lusso. Quali sono le tue convinzioni al riguardo?*

Il concetto di lusso è culturale, strettamente legato all'esperienza personale e quindi destinato ad evolversi nel tempo. Ciò che oggi ci appare esclusivo e percepito come lussuoso non necessariamente lo era in passato. Il silenzio, la semplicità, la naturalezza sono ad esempio vissuti oggi come un lusso proprio perché difficili da trovare. L'evoluzione del concetto di lusso è poi accentuata dalla sempre maggiore relazione tra culture e sensibilità differenti. Aggiungerei che oggi il concetto evoluto di lusso non può prescindere da una vera consapevolezza della qualità dell'ambiente in cui viviamo e degli oggetti di cui ci circondiamo, di materiali, dettagli, lavorazioni. Una dimensione che, per quanto mi riguarda, si riflette in uno stile di vita discreto e mai ostentativo, in cui il piacere che deriva dal possedere un prodotto ben disegnato sia autentico e affiancato dalla sicurezza del rispetto verso valori più generali.

*Come altri settori, anche quello dell'arreda sta vivendo una fase di grande trasformazione, in particolare dal punto di vista distributivo con una sempre maggiore internazionalizzazione. Immagini che questa tendenza influisca sulle scelte progettuali?*

Il nostro design e in particolare lo stile di vita italiano di cui è la diretta espressione, vengono sempre più considerati come un modello per molti paesi. Naturalmente questa tendenza rappresenta una grande opportunità per le aziende italiane. Credo che questo vantaggio vada interpretato come uno stimolo per migliorare la qualità della

*In home furnishings, as in other product sectors, the concept of luxury is clearly evolving. What are your beliefs on this?*

The concept of luxury is cultural, closely linked to personal experience and, therefore, fated to evolve over time. What today appears exclusive and is perceived as luxurious has not necessarily been so in the past. For example, silence, simplicity and naturalness are now seen as a luxury, because they are hard to find. The evolution of the concept of luxury is further enhanced by a constantly increasing interaction with different cultures and sensitivities. Moreover, today the evolved concept of luxury must always take into consideration the quality of the environment where we live and of the objects around us, including materials, details and finishes. A dimension that, as far as I am concerned, is reflected in a discreet and never "attention-seeking" lifestyle, in which the pleasure that derives from owning a well-designed product is authentic and supported by the guarantee of compliance with more general values.

*Like other sectors, the furniture sector is also undergoing a phase of huge transformation, in particular from the distribution point of view, with ever-increasing internationalisation. Do you imagine that this trend affects design choices?*

Our design, and in particular the Italian lifestyle of which it is the direct expression, are increasingly considered as a model for many countries. Of course this trend represents a great opportunity for Italian companies. I believe that this advantage should be construed as an incentive to improve the quality of the proposal: formal research, technical innovation, attention to detail







“With Fjord we tried to suggest a new stylistic interpretation, where natural materials, such as wood and stone, are grafted onto the rigorous frame of the aluminium chassis.”

proposta: la ricerca formale, l'innovazione tecnica, l'attenta cura del dettaglio devono essere sempre percepibili così da confermare il valore del made in Italy. Un aspetto che con Noorth abbiamo preso in forte considerazione.

*La ricerca dell'innovazione tecnica è una costante nel tuo lavoro, quasi una tua cifra stilistica inconfondibile. Da cosa nasce questa tua scelta?*

Credo che il settore dell'arredo in generale necessiti di un nuovo approccio progettuale. Si tratta di una esigenza anzitutto ambientale e cioè legata alla riduzione dei consumi, al riciclo dei materiali, ai principi di sostenibilità ormai ampiamente noti e condivisi. Ma non solo, nella progettazione del bagno è importante considerare che, a differenza di altri ambiti della casa, l'acqua e il vapore sono elementi imprescindibili. È quindi estremamente importante che la scelta dei materiali e le relative tecnologie da utilizzare per la realizzazione degli arredi abbiano caratteristiche tecniche altamente performanti, che tengono conto dell'usura e il deterioramento che deriva dalla presenza costante di questi elementi.

*Perché il nome Fjord?*

È un nome evocativo. Riconducibile all'acqua, elemento principe dell'ambiente bagno, ma anche di tranquillità e silenzio. Sinonimo di quiete e tranquillità, sensazioni che mi trasmettono quegli straordinari paesaggi naturali, tipici del nord Europa.

must always be evident so as to confirm the value of Made in Italy. An aspect that we have taken into consideration with Noorth.

*The pursuit of technical innovation is a characteristic feature of your work, almost an unmistakable stylistic trait. Where does this choice come from?*

I think that the furnishing sector in general needs a new approach to design. This is primarily an environmental requirement associated with reducing consumption, material recycling and sustainability principles that are now widely known and shared. In addition, when designing bathroom environments, it is important to take into consideration that, unlike other areas of the home, water and steam are essential elements. It is therefore extremely important to choose materials with high-performance technical characteristics - and this also applies to the technologies that will be used to create the furnishings - which must take into account wear and tear and deterioration due to the constant presence of these elements.

*Why was the name Fjord chosen?*

It is an evocative name. It is linked to the concept of water, the main element of a bathroom, but also of calmness and silence. It is synonymous with feelings of peace and tranquillity, which I feel are conveyed by these extraordinary natural landscapes, typical of Northern Europe.



# Puro Collection

design by Michele Marcon

Un design essenziale e raffinato fatto di superfici preziose e geometrie perfette, un sistema componibile che offre un'ampia varietà di soluzioni nel rispetto di un concept che nasce dall'essenza della materia, sempre preziosa, e dall'impostazione architettonica dello spazio con soluzioni strutturali pensate anche per configurazioni a isola. L'assenza della maniglia, sostituita da una gola superiore frontale e laterale, accentua la purezza dei volumi, così come i lavabi speciali che si integrano perfettamente nei top. La luce LED integrata negli elementi sottolinea la geometria e valorizza i tratti inconfondibili di marmi, pietre e legni esclusivi.

With an essential and refined design featuring fine surfaces and razor-sharp geometrical shapes, this modular system offers a wide variety of solutions while staying true to a concept that draws inspiration from the ever-precious essence of matter and from the architectural approach to space with structural solutions engineered for island-based layouts as well. The lack of the door handle, replaced by an upper front and side groove, emphasizes the pure forms of the volumes, just like the distinctive washbasins that are perfectly built into the surface tops. The LED light highlights the geometry and the unmistakable features of exclusive marble, stone and veneer surfaces.

Un design essentiel et raffiné composé de surfaces luxueuses et de géométries parfaites, un système modulable offrant une large éventail de solutions dans le respect d'un concept fruit de l'essence même de la matière, toujours noble, et de la configuration architecturale de l'espace proposant des solutions structurelles également conçues pour les agencements en îlot. L'absence de la poignée, remplacées par une gorge sur le devant et sur le côté, accentue la pureté des volumes, tout comme les lavabos spéciaux qui s'intègrent parfaitement aux plans. L'éclairage à LED intégré dans les éléments sublime la géométrie tout en valorisant les caractéristiques inimitables du marbre, de la pierre et des bois nobles.

Das sich aufs Wesentliche beschränkende und raffinierte Design, das aus edlen Oberflächen und perfekten geometrischen Formen besteht und eine Vielzahl von Möglichkeiten innerhalb eines Konzepts bietet, ist aus der besonderen Wertschätzung des verwendeten Materials und aus der architektonisch durchdachten Einteilung des Raumes mit selbst Inselkonfigurationen berücksichtigenden Gestaltungsideen hervorgegangen. Das Fehlen des Griffs, der oben durch eine vordere und seitliche Gehrung ersetzt wurde, unterstreicht die Reinheit der Rauminhalts auf ähnliche Weise, wie die speziellen Waschbecken sich perfekt in die Platten integrieren. Das in die Elemente integrierten Led-Lichter heben die geometrischen Formen hervor und werten die unverwechselbaren Eigenschaften von Marmor, Stein und Edelhölzern zusätzlich auf.

Изысканный и утонченный дизайн, включающий в себя драгоценные поверхности и безупречные геометрические формы, составная модульная система, предлагающая огромные возможности сочетаний. Концепция опирается на сущность драгоценных материалов, и на архитектурное осмысление пространства, включающего структурные решения, которые можно конфигурировать в качестве отдельно стоящего "острова". Отсутствие ручек, замененных верхним или боковым пазом на фасаде, подчеркивает чистоту форм, также как и специальные раковины, которые безупречно интегрируются в столешницы. Встроенная светодиодная подсветка элементов подчеркивает геометрию и придает ценность необычайным характеристикам мрамора, камней и драгоценных сортов древесины.

PURO 19.01

Medea  
Fango  
Cristalplant  
216 (108 + 108) x 35,5 x 51 cm  
85" (42 1/2" + 42 1/2") x 14" x 20 1/8"

Top sospeso integrato Next 56, basi, fianchi a 45° e boiserie in pietra Medea. Specchiera Vetra sp. 2,8 cm con retroilluminazione a LED quattro lati. Colonne a 45° in laccato Fango opaco. Vasca Oval in Cristalplant. Rubinetteria Flow in acciaio inox satinato con cartuccia tradizionale.

Next 56 wall-hung built-in top, base units, 45° sides and Pietra Medea finish woodwork. Vetra mirror, th. 2.8 cm, with all-round LED backlight. Matt Fango lacquered 45° columns. Oval Cristalplant bathtub. Flow taps in brushed stainless steel, with traditional cartridge.

Plan suspendu intégré Next 56, bases, côtés à 45° et boiserie en pierre Medea. Miroir Vetra ép. 2,8 cm avec rétroéclairage à LED sur les quatre côtés. Colonnes avec chanfrein à 45° en laqué Fango mat. Baignoire Oval en Cristalplant. Robinetterie Flow en acier inox satiné avec cartouche traditionnelle.

Integrierte hängende Platte Next 56, Unterbauten, Ausführungsseiten mit 45° und Täfelung in der Farbe Pietra Medea. Spiegel Vetra, Dicke 2,8 cm, mit vierseitiger LED-Hintergrundbeleuchtung. Säule mit 45° Abkantung mit Lackoberfläche im Farbton Fango Matt. Wanne Oval aus Cristalplant. Wasserhähne Flow aus satiniertem Edelstahl mit traditioneller Kartusche.

Интегрированная подвесная столешница Next 56, тумбы, боковины с фаской 45° и стеновые панели из камня Medea. Зеркало Vetra толщ. 2,8 см с подсветкой из светодиодов с четырех сторон. Шкаф-пеналы с фаской 45° в матовом лаке Fango. Ванна Oval из Cristalplant. Смесители Flow из satinированной нержавеющей стали с традиционным картриджем.























PURO 19.02

Medea  
 216 (108 + 108) x 35,5 x 51 cm  
 85" (42 1/2" + 42 1/2") x 14" 20 1/8"

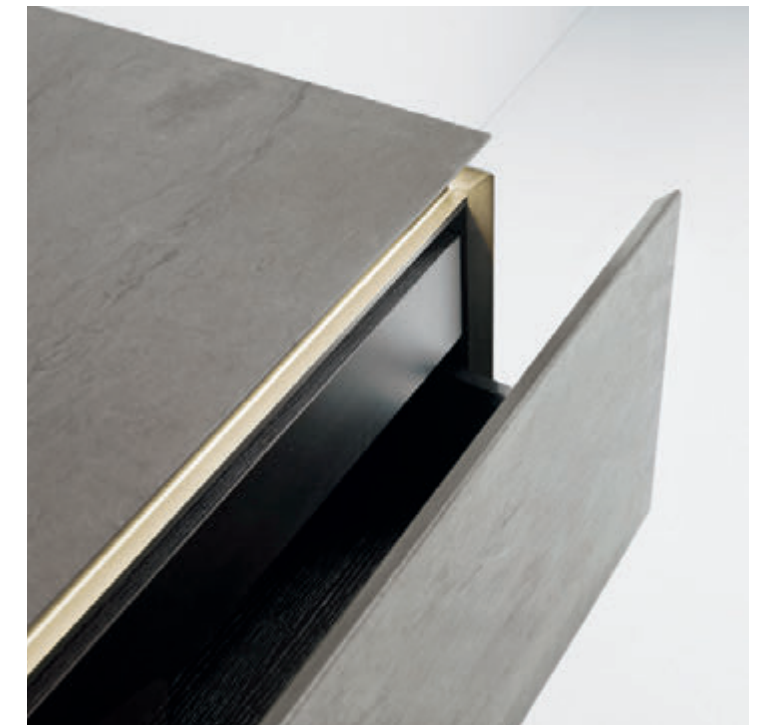

Top integrato Height 90, basi e fianchi a 45° in pietra Medea. Specchiere Vetra sp. 2,8 cm con retroilluminazione a LED due lati verticali. Rubinetteria Flow in acciaio inox satinato con cartuccia tradizionale. | Height 90 built-in top, Pietra Medea finish 45° base units and sides. Vetra mirrors, th. 2,8 cm, with double-sided vertical LED backlight. Flow taps in brushed stainless steel, with traditional cartridge. | Plan intégré Height 90, bases et côtés à 45° en pierre Medea. Miroirs Vetra ép. 2,8 cm avec rétroéclairage à LED sur les deux côtés verticaux. Robinetterie Flow en acier inox satiné avec cartouche traditionnelle. | Integrierte Platte Height 90, Unterbauten und Ausführungsseiten mit 45° Abkantung in der Farbe Pietra Medea. Spiegel Vetra, Dicke 2,8 cm, mit LED-Hintergrundbeleuchtung auf den beiden vertikalen Seiten. Wasserhähne Flow aus satiniertem Edelstahl mit traditioneller Kartusche. | Интегрированная столешница Height 90, тумбы и боковины с фаской 45° из камня Medea. Зеркала Vetra толщ. 2,8 см с подсветкой из светодиодов с двух вертикальных сторон. Смесители Flow из satinированной нержавеющей стали с традиционным картриджем.





PURO 19.03

Noce Canaletto

Medea

Zinco

216 (108 + 108) x 35,5 x 51 cm

85"(42 1/2" + 42 1/2") x 14" x 20 1/8"



Lavabo in appoggio Keel 60 e top in Pietra Medea. Basi e fianchi a 45° in Noce Canaletto. Specchiera Ekos V con retroilluminazione a LED quattro lati, profilo in alluminio laccato Zinco. Mensole Ljos in alluminio laccato Zinco, complete di accessori e retroilluminazione a LED. Rubinetteria Flow in acciaio inox finitura PVD nero opaco con cartuccia progressiva. | Keel 60 sit-on washbasin, Pietra Medea top. Noce Canaletto 45° base units and sides. Ekos V mirror with all-round LED backlight, Zinco finish lacquered aluminium profile. Ljos shelves made of Zinco finish lacquered aluminium, complete with accessories and LED backlight. Flow taps in stainless steel, matt black PVD finish, with progressive cartridge. | Lavabo à poser Keel 60 et plan en Pierre Medea. Bases et côtés à 45° en Noce Canaletto. Miroir Ekos V avec rétroéclairage à LED quatre côtés, profil en aluminium laqué Zinco. Étagères Ljos en aluminium laqué Zinco, pourvues d'accessoires et rétroéclairage à LED. Robinetterie Flow en acier inox finition PVD noir mat avec cartouche progressive. Aufgawaschbecken Keel 60 und Platte in der Farbe Pietra Medea. Unterbauten und Ausführungsseiten mit 45° Abkantung aus Noce Canaletto. Spiegel Ekos V mit vierseitiger LED-Hintergrundbeleuchtung, Profil aus Aluminium mit Lackoberfläche im Farbton Zinco. Ablageflächen Ljos aus Aluminium mit Lackoberfläche im Farbton Zinco, komplett mit Zubehör und LED-Hintergrundbeleuchtung. Wasserhähne Flow aus Edelstahl Oberflächenausführung mit mattschwarzer PVD-Beschichtung und progressiver Kartusche. | Накладная раковина Keel 60 и столешница из камня Medea. Тумбы и боковины с фаской 45° из ореха Noce Canaletto. Зеркало Ekos V с подсветкой из светодиодов с четырех сторон, с лакированным алюминиевым профилем Zinco. Полки Ljos из лакированного алюминия Zinco в комплекте с аксессуарами и светодиодной подсветкой. Смесители Flow из нержавеющей стали с черной матовой отделкой PVD с прогрессивным картриджем.



PURO 19.04

Rovere Mezza Fiamma

Bianco

Milltek Solid

252 (126 + 126) x 35,5 x 56,5 cm

99 1/4" (49 5/8" + 49 5/8") x 14" x 22 1/4"

Top integrato Tray 94 in Milltek Solid con illuminazione a LED inferiore. Basi, fianchi a 45° e schienale di finitura in Rovere Mezza Fiamma. Specchiera Prisma a soffitto. Parete di sostegno in laccato Bianco opaco con predisposizione per sanitari. Sanitari Senna in ceramica opaca. Colonne in laccato Bianco opaco con illuminazione a LED superiore ed inferiore. Rubinetteria Flow in acciaio inox satinato con cartuccia tradizionale.

Tray 94 Milltek Solid in-built top with LED lower lighting. Rovere Mezza Fiamma finish base units, 45° side and back panel. Prisma ceiling-mounted mirror unit. Matt Bianco lacquered supporting wall with plumbing fixtures for sanitary ware. Senna matt ceramic sanitary ware. Matt Bianco lacquered columns with upper and lower LED lighting. Flow taps in stainless steel, with traditional cartridge.

Plan intégré Tray 94 en Milltek Solid avec éclairage à LED inférieur. Bases, côtés à 45° et dossier de finition en Rovere Mezza Fiamma. Miroir plafond Prisma. Paroi de soutien en laqué Bianco mat prévu pour les sanitaires. Sanitaires Senna en céramique mate. Colonnes en laqué Bianco mat avec éclairage à LED haut et bas. Robinetterie Flow en acier inox satiné avec cartouches traditionnelles.

Integrierte Platte Tray 94 aus Milltek Solid mit Led-Beleuchtung im unteren Bereich. Unterbauten, Seitenteile mit 45° Abkantung und Rückenteil mit Oberflächengestaltung aus Rovere im Farbton Mezza Fiamma. Deckenspiegelfläche Prisma. Stützwand mit Lackoberfläche im Farbton Bianco Matt mit Vorrüstung für Einbau von Sanitäranlagen. Sanitäranlagen Senna aus matter Keramik. Säulen mit Lackoberfläche im Farbton Bianco Matt mit LED-Beleuchtung im oberen und unteren Bereich. Wasserhähne Flow aus satiniertem Edelstahl mit traditioneller Kartusche.

Интегрированная столешница Tray 94 из Milltek Solid с подсветкой нижним светодиодом. Тумбы и боковины с фаской 45° и спинка из дуба Rovere Mezza fiamma. Зеркало Prisma потолочной установки. Опорная стена в белом матовом лаке с возможностью установки сантехники. Сантехника Senna из матовой керамики. Шкафы-пеналы в белом матовом лаке с подсветкой нижним и верхним светодиодом. Смесители Flow из satinированной нержавеющей стали с традиционным картриджем.























PURO 19.05

Rovere Termocotto

Emperador

216 (90 + 126) x 46,1 x 51 cm

85" (35 3/8" + 49 5/8") x 18 1/8" x 20 1/8"

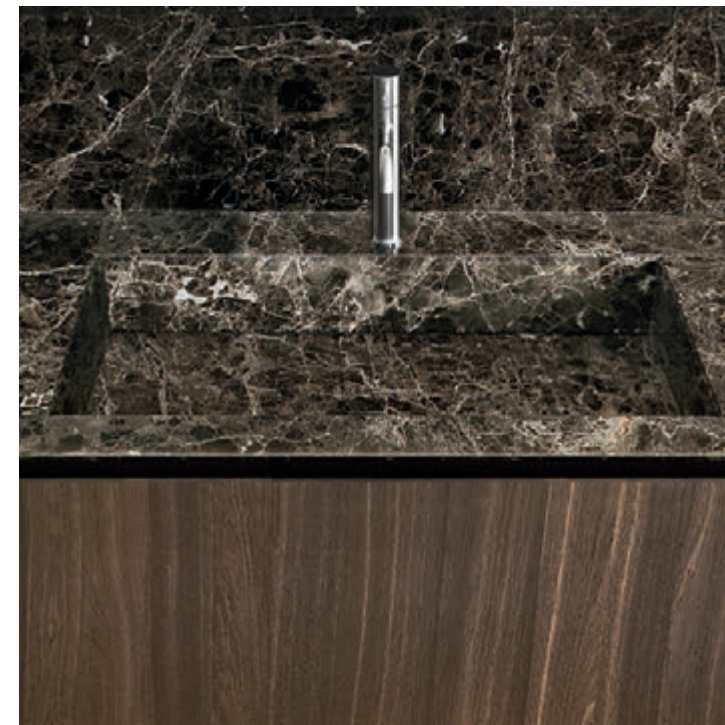

Top integrato Next 90 e alzata in marmo Emperador. Basi e fianchi a 45° in Rovere Termocotto. Specchiera Vetra sp. 2,8 cm con retroilluminazione a LED quattro lati. Lampade Moon a LED. Rubinetteria Flow in acciaio inox satinato con cartuccia tradizionale. | Next 90 built-in top and Emperador marble back-splash. Base units and 45° Rovere Termocotto sides. Vetra mirror, th. 2.8, with all-round LED backlight. Moon LED lamps. Flow taps in brushed stainless steel, with traditional cartridge. | Plan intégré Next 90 et dossier en marbre Emperador. Bases et côtés à 45° en Rovere Termocotto. Miroir Vetra ép.2,8 cm avec rétroéclairage à LED sur les quatre côtés. Lampes Moon à LED. Robinetterie Flow en acier inox satiné avec cartouche traditionnelle. | Integrierte Platte Next 90 und Aufbau aus Emperador-Marmor. Unterbauten und Seitenausführungen mit 45° Abkantung aus Eiche im Farbton Termocotto. Spiegel Vetra, Dicke 2,8 cm, mit vierseitiger LED-Hintergrundbeleuchtung. LED-Leuchten Moon. Wasserhähne Flow aus satiniertem Edelstahl mit traditioneller Kartusche. | Интегрированная столешница Next 90 и задняя стенка из мрамора Emperador. Тумбы и боковины с фаской 45° из дуба Rovere Termocotto. Зеркало Vetra толщ.2,8 см с подсветкой из светодиодов с четырех сторон. Светодиодные лампы Moon. Смесители Flow из satinированной нержавеющей стали с традиционным картриджем.





PURO 19.06

Rovere Miele

Cristalplant

198 (72 + 126) x 35,5 x 51 cm

78" (28 3/8" + 49 5/8") x 14" x 20 1/8"



Lavabo in appoggio Blend 81 in Cristalplant. Top in Rovere Miele con illuminazione a LED inferiore. Basi, vano a giorno con illuminazione a LED e fianchi a 45° in Rovere Miele. Specchiere Vetra sp. 2,8 cm con retroilluminazione a LED quattro lati. Rubinetteria Flow in acciaio inox satinato con cartuccia tradizionale. | Blend 81 Cristalplant sit-on washbasin. Rovere Miele top with lower LED lighting. Base units, open shelving with LED lighting and Rovere Miele 45° sides. Vetra mirrors, th. 2,8 cm, with all-round LED backlight. Flow taps in brushed stainless steel, with traditional cartridge. | Lavabo à poser Blend 81 en Cristalplant. Plan en Rovere Miele avec éclairage à LED bas. Bases, élément à jour avec éclairage à LED et côtés à 45° en Rovere Miele. Miroirs Vetra ép. 2,8 cm avec rétroéclairage à LED sur les quatre côtés. Robinetterie Flow en acier inoxydable avec cartouche traditionnelle. | Aufgawaschbecken Blend 81 aus Cristalplant. Platte aus Rovere im Farbton Miele mit LED-Beleuchtung im unteren Bereich. Unterbauten, offene Fächer mit LED-Beleuchtung und Seitenausführung mit 45° Abkantung aus Rovere im Farbton Miele. Spiegel Vetra, Dicke 2,8 cm, mit vierseitiger LED-Hintergrundbeleuchtung. Wasserhähne Flow aus satiniertem Edelstahl mit traditioneller Kartusche. Накладная раковина Blend 81 из Cristalplant. Столешница из дуба Rovere Miele с подсветкой нижним светодиодом. Тумбы, открытый элемент со светодиодной подсветкой и боковинами с фаской 45° из дуба Rovere Miele. Зеркала Vetra толщ. 2,8 см с подсветкой из светодиодов с четырех сторон. Смесители Flow из satinированной нержавеющей стали с традиционным картриджем.



Rovere Termocotto  
 Cristalplant  
 Milltek Solid  
 216 (108+108) x 72 x 51 cm  
 85" (42 1/2" + 42 1/2" ) x 28 3/8" x 20 1/8"

Lavabo in appoggio Step 63.14 in Cristalplant con illuminazione a LED inferiore. Top, basi e fianchi a 45° in Rovere Termocotto. Zoccolo in laccato Nero opaco. Specchiera Prisma a soffitto. Vasca Ska 35 con schienale in Milltek Solid e illuminazione a LED. Boiserie e pedana in Rovere Termocotto. Piatto doccia Line in Milltek Solid. Sanitari Senna in ceramica lucida.

Step 63.14 Cristalplant sit-on washbasin with lower LED backlight. Termocotto Rovere top, base units and 45° sides. Matt Nero lacquered plinth. Prisma ceiling-mounted mirror. Ska 35 bathtub with Milltek Solid backrest and LED lighting. Rovere Termocotto woodwork and footboard. Line Milltek Solid shower tray. Senna polished ceramic sanitary ware.

Lavabo à poser Step 63.14 en Cristalplant avec éclairage à LED bas. Plan, bases et côtés à 45° en Rovere Termocotto. Socle laqué Nero mat. Miroir Prisma plafond. Baignoire Ska 35 avec dossier en Milltek Solid et éclairage à LED. Boiserie et socle en Rovere Termocotto. Bac de douche Line en Milltek Solid. Sanitaires Senna en céramique brillante.

Auflagewaschbecken Step 63.14 aus Cristalplant mit LED-Beleuchtung im unteren Bereich. Platte, Unterbauten und Seitenausführungen mit 45° Abkantung aus Rovere im Farbton Termocotto. Sockel mit Lackoberfläche in Nero Matt. Deckenspiegelfläche Prisma. Wanne Ska 35 mit Rückenteil aus Milltek Solid und LED-Beleuchtung. Täfelung und Auflage aus Eiche im Farbton Termocotto. Duschteller Line aus Milltek Solid. Sanitäranlagen Senna aus glänzender Keramik.

Накладная раковина Step 63.14 из Cristalplant с подсветкой нижним светодиодом. Столешница, тумбы и боковины с фаской 45° из дуба Rovere Termocotto. Цоколь в черном матовом лаке. Зеркало Prisma потолочной установки. Ванна Ska 35 с задней стенкой из Milltek Solid и светодиодной подсветкой. Стеновые панели и подставка из дуба Rovere Termocotto. Поддон для душа Line из Milltek Solid. Сантехника Senna из глянцевой керамики.









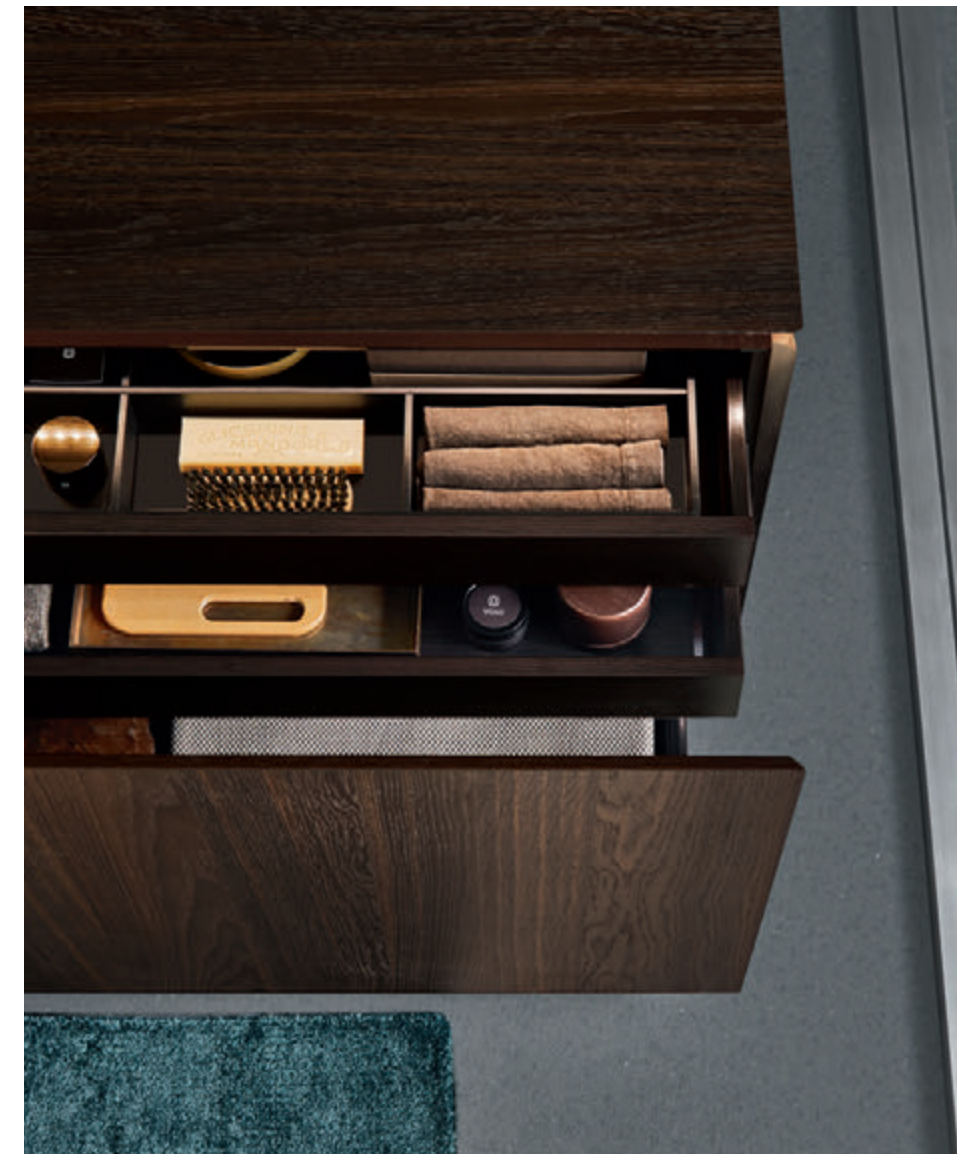







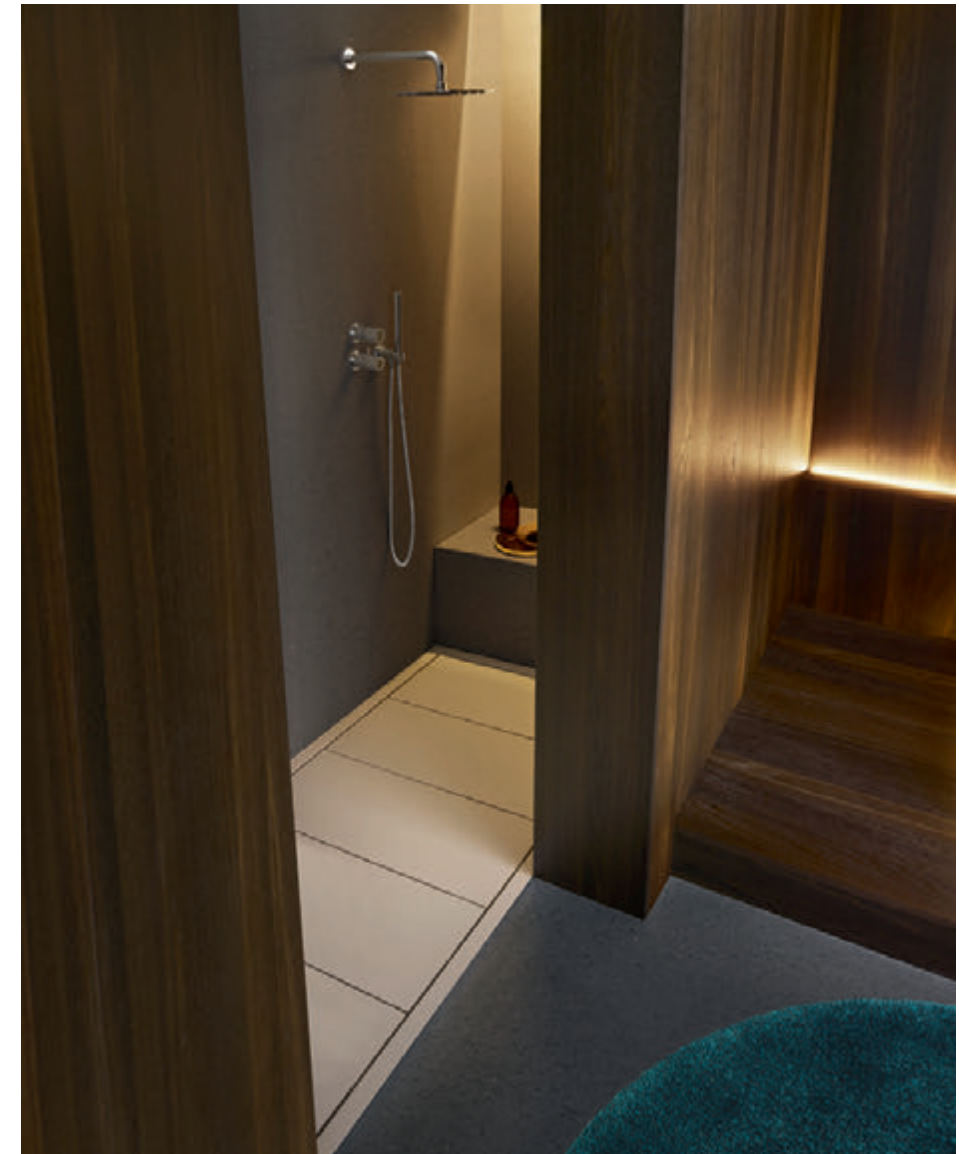





PURO 19.08

Lipica Unito

Sabbia

Platino

ceramica | ceramic

225 (90 + 45 + 90) x 81 x 51 cm

88 5/8" (35 3/8" + 17 3/4" + 35 3/8") x 31 7/8" x 20 1/8"



Lavabi sottopiano Net 54.31 in ceramica lucida. Top in marmo Lipica Unito. Basi e fianchi a 45° in laccato Sabbia lucido. Zoccolo in laccato Nero opaco. Specchiera Ekos V con retroilluminazione a LED quattro lati e illuminazione a LED due lati verticali interni, profilo in alluminio laccato Platino. Rubinetteria Flow in acciaio inox satinato con cartuccia tradizionale. | Net 54.31 glossy ceramic undermounted washbasins. Lipica Unito marble top. Sabbia glossy lacquered base units and 45° sides. Matt Nero lacquered plinth. Ekos V mirror with all-round LED backlight and double-sided interior vertical LED lighting, Platino finish lacquered aluminium profile. Flow taps in brushed stainless steel, with traditional cartridge. Lavabos encastrés Net 54.31 en céramique brillante. Plan en marbre Lipica Unito. Bases et côtés à 45° laqué Sabbia brillant. Socle laqué Nero mat. Miroir Ekos V avec rétroéclairage à LED quatre côtés et éclairage à LED deux côtés verticaux internes, profil en aluminium laqué Platino. Robinetterie Flow en acier inox satiné avec cartouches traditionnelles. | Unterbauwaschbecken Net 54.31 aus glänzender Keramik. Platte aus Marmor Lipica Unito. Unterbauten und Seitenausführungen mit 45° Abkantung und Lackoberfläche im Farbton Sabbia glänzend. Sockel mit Lackoberfläche in Nero Matt. Spiegel Ekos H mit vierseitiger LED-Hintergrundbeleuchtung und LED-Beleuchtung auf den beiden vertikalen Innenseiten, Profil aus Aluminium mit Lackoberfläche im Farbton Platino. Wasserhähne Flow aus satiniertem Edelstahl mit traditioneller Kartusche. | Раковины, устанавливаемые под столешницу, Net 54.31 из глянцевой керамики. Столешница из мрамора Lipica Unito. Тумбы и боковины с фаской 45° в глянцевом лаке Sabbia. Цоколь в черном матовом лаке. Зеркало Ekos V с четырехсторонней светодиодной подсветкой и светодиодной подсветкой с двух вертикальных внутренних сторон, с профилем из лакированного алюминия Platino. Смесители Flow из satinированной нержавеющей стали с традиционным картриджем.



PURO 19.09

Bianco Arabescato

Bianco

Cristalplant

Milltek Solid

270 (90 + 90 + 90) x 46,1 x 51 cm

106 1/4" (35 3/8" + 35 3/8" + 35 3/8") x 18 1/8" x 20 1/8"

Top sospeso integrato Strict 140 in marmo Bianco Arabescato. Erogatori H2O cromo. Basi in laccato Bianco opaco. Zoccolo in laccato Nero opaco. Specchiera Vetra sp. 2,8 cm con retroilluminazione a LED due lati superiore e inferiore. Vasca Styling R01 in Cristalplant con rivestimento in laccato Bianco opaco. Piatto doccia Line in Milltek Solid. Sanitari Senna in ceramica lucida.

Strict 140 wall-hung in-built top made of Bianco Arabescato marble. H2O chrome spouts. Matt Bianco lacquered cabinet. Matt Nero lacquered plinth. Vetra mirror, th. 2.8 cm, with double-sided upper and lower LED backlight. Styling R01 Cristalplant bathtub, matt Bianco lacquered coating. Line Milltek Solid shower tray. Senna polished ceramic sanitary ware.

Plan suspendu intégré Strict 140 en marbre Bianco Arabescato. Bacs d'écoulement H2O chrome. Bases en laqué Bianco mat. Socle laqué Nero mat. Miroir Vetra ép. 2,8 cm avec rétroéclairage à LED sur les deux côtés haut et bas. Baignoire Styling R01 en Cristalplant avec revêtement laqué Bianco mat. Bac de douche Line en Milltek Solid. Sanitaires Senna en céramique brillante.

Hängende integrierte Platte Strict 140 aus Marmor Bianco Arabescato. Auslauf H2O Chrom. Unterbauten mit Lackoberfläche im Farbton Bianco Matt. Sockel mit Lackoberfläche in Nero Matt. Spiegel Vetra, Dicke 2,8 cm, mit LED-Hintergrundbeleuchtung oben und unten auf den beiden Seiten. Wanne Styling R01 aus Cristalplant mit Verkleidung mit Lackoberfläche im Farbton Bianco Matt. Duschteller Line aus Milltek Solid. Sanitäranlagen Senna aus glänzender Keramik.

Интегрированная подвесная столешница Strict 140 из мрамора Bianco Arabescato. Хромированные смесители. Тумбы в белом матовом лаке. Цоколь в черном матовом лаке. Зеркало Vetra толщ. 2,8 см с подсветкой из светодиодов с двух сторон, верхней и нижней. Ванна Styling R01 из Cristalplant с отделкой в белом матовом лаке. Поддон для душа Line из Milltek Solid. Сантехника Senna из глянцевой керамики.























PURO 19.10

Bosco

Corian

270 (90 + 90 + 90) x 23,5 x 51 cm | Top 180 x 12 x 51 cm

106 1/4" (35 3/8" + 35 3/8" + 35 3/8") x 18 1/8" x 20 1/8" | Top 70 7/8" x 4 3/4" x 20 1/8"



Top sospeso integrato Next 90 in Corian. Basi, top e fianchi a 45° in laccato Bosco lucido. Specchiera Vetra sp. 2,6 cm con retroilluminazione a LED due lati superiore e inferiore. Rubinetteria Flow in acciaio inox satinato con cartuccia tradizionale. | Next 90 wall-hung in-built Corian top. Glossy Bosco lacquered base units, tops and 45° sides. Vetra mirror, th. 2.8 cm, with double-sided upper and lower LED backlight. Flow taps in brushed stainless steel, with traditional cartridge. | Plan suspendu intégré Next 90 en Corian. Bases, plans et côtés à 45° en laqué Bosco brillant. Miroir Vetra ép. 2,6 cm avec rétroéclairage à LED sur les deux côtés haut et bas. Robinetterie Flow en acier inox satiné avec cartouches traditionnelles. | Integrierte hängende Platte Next 90 aus Corian. Unterbauten, Platte und Seitenausführungen mit 45° Abkantung und Lackoberfläche im Farbton Bosco glänzend. Spiegel Vetra, Dicke 2,8 cm, mit LED-Hintergrundbeleuchtung oben und unten auf den beiden Seiten. Wasserhähne Flow aus satiniertem Edelstahl mit traditioneller Kartusche. | Интегрированная подвесная столешница Next 90 из Corian. Тумбы, столешница и боковины с фаской 45° в глянцевом лаке Bosco. Зеркало Vetra толщ. 2,6 см с подсветкой из светодиодов с двух сторон, верхней и нижней. Смесители Flow из satinированной нержавеющей стали с традиционным картриджем.





PURO 19.11

Corian  
 180 x 13 x 51 cm  
 70 7/8" x 5 1/8" x 20 1/8"



Top sospeso integrato Unique con vassoio in Corian. Porta asciugamano in Corian. Specchiere contenitore ad incasso con illuminazione a LED inferiore. Rubinetteria Flow in acciaio inox lucido con cartuccia tradizionale. | Unique wall-hung in-built top with Corian tray. Corian towel rack. Recessed storage mirror units with lower LED lighting. Flow taps in polished stainless steel, with traditional cartridge. | Plan suspendu intégré Unique avec plateau en Corian. Porte-serviettes en Corian. Miroirs de rangement encastrés avec éclairage à LED bas. Robinetterie Flow en acier inox brillant avec cartouches traditionnelles. | Integrierte hängende Platte Unique mit Becken aus Corian. Handtuchhalter aus Corian. Eingebaute Spiegel / Behältnisse mit LED-Beleuchtung im unteren Bereich. Wasserhähne Flow aus glänzendem Edelstahl mit traditioneller Kartusche. Интегрированная подвесная столешница Unique с поддоном из Corian. Полотенцедержатель из Corian. Встроенные зеркала-шкафчики с подсветкой нижним светодиодом. Смесители Flow из блестящей нержавеющей стали с традиционным картриджем.



# Zenit Collection

design by Michele Marcon

Geometrie definite ed essenziali: Zenit è un sistema di contenitori sottolavabo, monoblocco o componibili, disponibili sia nella versione a terra che nella versione sospesa, per una massima versatilità funzionale. Superfici in finiture laccate, in essenza o argilla ne permettono la più ampia personalizzazione formale. Il taglio a 45° gradi come tratto continuo tra frontali e fianchi, la gola centrale come elemento funzionale ma anche di definizione estetica dell'immagine.

Well-defined and essential geometries: Zenit is a container system designed for under the washbasin. It comes with a single-block or modular layout, both available as floor-mounted and wall-mounted versions for maximum functional versatility. Lacquered surfaces with veneer finish or in clay ensure the widest possible customising options. The 45° cutting angle serves as continuity between the front and sides, the central groove as a functional element, but with a markedly aesthetic connotation.

Des géométries définies et essentielles : Zenit est une série d'éléments de rangement de dessous de lavabo, monobloc ou modulables, en version sol ou suspendue, pour une polyvalence maximale de la fonctionnalité. Des surfaces en finition laquée, essence ou argile, permettent une personnalisation formelle optimale. Une découpe à 45 degrés dessinant un trait continu entre façades et flancs, une gorge centrale devenant non seulement un élément fonctionnel mais aussi de définition esthétique de l'image.

Klare und essentielle Formen: Zenit ist ein kompaktes oder modulares System von unter dem Waschbecken angebrachten Behältnissen, das sowohl in der Stand- als auch in der Hängeversion erhältlich ist, um maximale Funktionsvielfalt zu bieten. Oberflächen in lackierter Ausführung, in Holz oder Ton ermöglichen eine größtmögliche Gestaltungsfreiheit. Der Gehrungsschnitt von 45° stellt einen fließenden Übergang zwischen den Stirnseiten und den Seitenwänden dar. Die zentral angebrachte Aussparung soll nicht nur zweckdienlich sein, sondern auch zur Ästhetik des Gesamtbildes beitragen.

Четкие и минималистские геометрические формы: Zenit – это система устанавливаемых под раковину моноблочных или модульных шкафчиков, доступных как в напольной, так и подвесной версиях, для обеспечения максимальной функциональной универсальности. Поверхности с лакированной отделкой, в шпоне или из глины позволяют максимально персонализировать интерьер. Скошенная фаска под углом 45°, как единый элемент для фасадов и боковин, паз по центру створки, который является не только функциональным элементом, но и украшает внешний вид изделия.



ZENIT 19.01

Giada  
Cristalplant  
Milltek Solid  
99 (27 + 72) x 36 x 51 cm  
39" (10 5/8" + 28 3/8") x 14 1/8" x 20 1/8"

Lavabo in appoggio Keel 45 in Cristalplant con esterno laccato Giada opaco. Top in Cristalplant. Base con gola superiore e vano a giorno in laccato Giada opaco. Specchiera contenitore ad incasso con illuminazione a LED inferiore. Portasciugamani Darma. Sanitari Senna in ceramica opaca. Piatto doccia Line in Milltek Solid. Rubinetteria Flow in acciaio inox satinato con cartuccia progressiva.

Keel 45 Cristalplant sit-on washbasin with matt Giada finish lacquered outside. Cristalplant top. Base unit with upper groove and matt Giada finish lacquered open shelving. Recessed mirrored storage unit with lower LED lighting. Darma towel rack. Senna matt ceramic sanitary ware. Line Milltek Solid shower tray. Flow taps in brushed stainless steel, with progressive cartridge.

Lavabo à poser Keel 45 en Cristalplant avec extérieur laqué Giada mat. Plan en Cristalplant. Base avec gorge supérieure et élément à jour en laqué Giada mat. Miroir de rangement encastré avec éclairage à LED bas. Porte-serviettes Darma. Sanitaires Senna en céramique mate. Bac de douche Line en Milltek Solid. Robinetterie Flow en acier inox satiné avec cartouche progressive.

Auflagewaschbecken Keel 45 aus Cristalplant, Außenseite mit Lackoberfläche im Farbton Giada Matt. Platte aus Cristalplant. Unterbau mit obere Gehrung und offenem Fach sowie Lackoberfläche im Farbton Giada Matt. Eingebaute Spiegel / Behältnisse mit LED-Beleuchtung im unteren Bereich. Handtuchhalter Darma. Sanitäreanlagen Senna aus matter Keramik. Duschteller Line aus Milltek Solid. Wasserhähne Flow aus satiniertem Edelstahl mit progressiver Kartusche.

Накладная раковина Keel 45 из Cristalplant с наружной отделкой в матовом лаке Giada. Столешница из Cristalplant, тумбы с верхним пазом и открытым элементом в матовом лаке Giada. Встроенное зеркало-шкафчик с подсветкой нижним светодиодом. Полотенцедержатель Darma. Сантехника Senna из матовой керамики. Поддон для душа Line из Milltek Solid. Смесители Flow из satinированной нержавеющей стали с прогрессивным картриджем.















ZENIT 19.02

Rovere Tundra

Milltek Solid

162 (108 + 54) x 48 x 51 cm

63 3/4" (42 1/2" + 24 1/4") x 18 7/8" x 20 1/8"



Top integrato Still 04 in Milltek Solid. Basi con gola centrale e vano a giorno in Rovere Tundra. Specchiera Vetra sp. 2,8 cm. Lampada Linus 72 a LED. Rubinetteria Flow in acciaio inox satinato con cartuccia tradizionale. | Still 04 Milltek Solid in-built top. Base units with central groove and Tundra Rovere open shelving. Vetra mirror, th. 2.8 cm. Linus 72 LED lamp. Flow taps in brushed stainless steel, with traditional cartridge. | Plan intégré Still 04 en Milltek Solid. Bases avec gorge centrale et élément à jour en Rovere Tundra. Miroir Vetra ép. 2,8 cm. Lampe Linus 72 à LED. Robinetterie Flow en acier inox satiné avec cartouche traditionnelle. | Integrierte Platte Still 04 aus Milltek Solid. Unterbauten mit lotrechter Gehrung und offenem Fach aus Rovere im Farbton Tundra. Spiegel Vetra Dicke 2,8 cm. LED-Leuchte Linus 72. Wasserhähne Flow aus satiniertem Edelstahl mit traditioneller Kartusche. | Интегрированная столешница Still 04 из Milltek Solid. Тумбы с центральным пазом и открытым элементом из дуба Rovere Tundra. Зеркало Vetra толщ. 2,8 см. Светодиодная лампа Linus 72. Смесители Flow из сатирированной нержавеющей стали с традиционным картриджем.





ZENIT 19.03

Nuvola  
 Milltek Gel  
 216 (90 + 36 + 90) x 36 x 47 cm  
 85" (35 3/8" + 14 1/8" + 35 3/8") x 14 1/8" x 18 1/2"



Top integrato Stage 02 in Milltek Gel. Basi con gola superiore in laccato Nuvola lucido. Specchiera Air con retroilluminazione a LED. Rubinetteria Flow in acciaio inox satinato con cartuccia progressiva. | Stage 02 Milltek Gel in-built top. Glossy Nuvola lacquered base units with upper groove. Air mirror with LED backlight. Flow taps in brushed stainless steel, with progressive cartridge. | Plan intégré Stage 02 en Milltek Gel. Bases avec gorge en haut en laqué Nuvola brillant. Miroir Air avec rétroéclairage à LED. Robinetterie Flow en acier inox satiné avec cartouche progressive. Integrierte Platte Stage 02 aus Milltek Gel. Unterbau mit oberer Gehrung und Lackoberfläche im Farbton Nuvola Glänzend. Spiegel Air mit LED-Hintergrundbeleuchtung. Wasserhähne Flow aus satiniertem Edelstahl mit progressiver Kartusche. | Интегрированная столешница Stage 02 из Milltek Gel. Тумбы с верхним пазом в глянцевом лаке Nuvola. Зеркало Air со светодиодной подсветкой. Смесители Flow из сатинированной нержавеющей стали с прогрессивным картриджем.



ZENIT 19.04

Grafite  
Cristalplant  
63 x 88,5 x 47 cm  
24 3/4" x 34 7/8" x 18 1/2"

Basi con gola centrale in laccato Grafite opaco, lavabo Man 63 e vassoio in Cristalplant. Zoccolo in laccato Nero opaco. Specchiera Vetra sp. 2,8 cm con retroilluminazione a LED quattro lati. Colonne con struttura, vani a giorno e ante in laccato Grafite opaco. Consolle serie Bali. Rubinetteria Flow in acciaio inox satinato con cartuccia tradizionale.

Matt Grafite lacquered base units with central groove, Man 63 washbasin and tray in Cristalplant. Matt Nero lacquered plinth. Vetra mirror, th. 2.8 cm, with all-round LED backlight. Columns with matt Grafite lacquered frame, open shelving and doors. Bali series console. Flow taps in brushed stainless steel, with traditional cartridge.

Bases avec gorge centrale en laqué Grafite mat, lavabo Man 63 plateau en Cristalplant. Socle en laqué Nero mat. Miroir Vetra ép. 2,8 cm avec rétroéclairage à LED sur les quatre côtés. Colonnes avec structure, éléments à jour et portes en laqué Grafite mat. Étagère série Bali. Robinetterie Flow en acier inox satiné avec cartouches traditionnelles.

Unterbauten mit lotrechter Gehrung und Lackoberfläche im Farbton Grafite Matt, Waschbecken Man 63 und Becken aus Cristalplant. Sockel mit Lackoberfläche in Nero Matt. Spiegel Vetra, Dicke 2,8 cm, mit vierseitiger LED-Hintergrundbeleuchtung. Säulen mit Struktur, offene Fächer und Türen mit Lackoberfläche im Farbton Grafite Matt. Konsole Serie Bali. Wasserhähne Flow aus satiniertem Edelstahl mit traditioneller Kartusche.

Тумбы с центральным пазом в матовом лаке Grafite, раковина Man 63 и поддон из Cristalplant. Цоколь в черном матовом лаке. Зеркало Vetra толщ. 2,8 см с подсветкой из светодиодов с четырех сторон. Шкаф-пеналы с конструкцией, открытыми элементами и створками с отделкой в матовом лаке Grafite. Консоль серии Bali. Смесители Flow из satinированной нержавеющей стали с традиционным картриджем.



























ZENIT 19.05

Origano  
Cristalplant  
126 x 60 x 47 cm  
49 5/8" x 23 5/8" x 18 1/2"

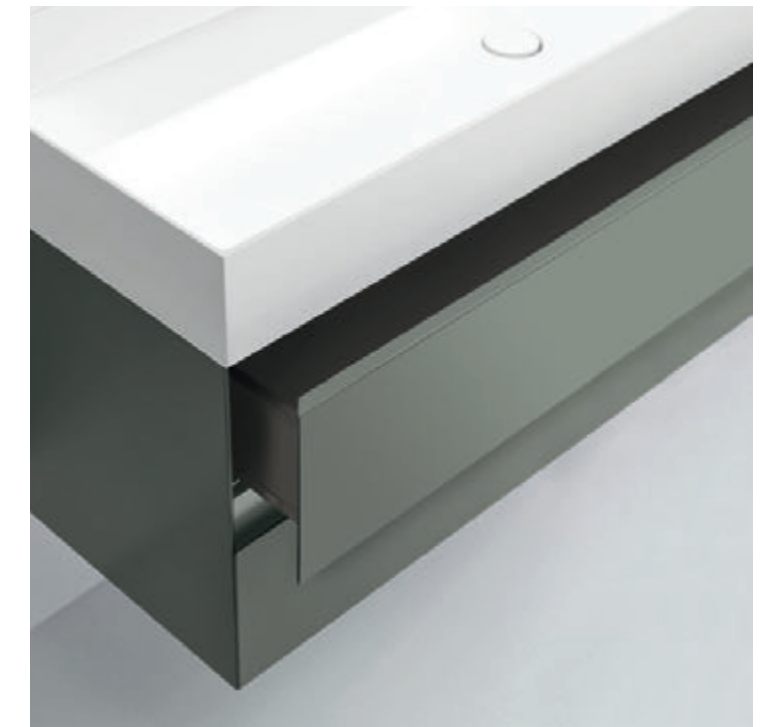

Base con gola centrale in laccato Origano opaco con lavabo Man 126 in Cristalplant. Specchiera Vetra sp. 2,8 cm con retroilluminazione a LED due lati superiore e inferiore. Pensili con anta a 45° in laccato Origano opaco. Rubinetteria Flow in acciaio inox satinato con cartuccia tradizionale. Matt Origano lacquered base unit with central groove, Man 126 washbasin in Cristalplant. Vetra mirror, th. 2.8 cm, with double-sided upper and lower LED backlight. Matt Origano lacquered wall units with 45° door. Flow taps in brushed stainless steel, with traditional cartridge. | Base avec gorge centrale en laqué Origano mat avec lavabo Man 126 en Cristalplant. Miroir Vetra ép. 2,8 cm avec rétroéclairage à LED sur les deux côtés haut et bas. Meubles hauts avec porte à 45° en laqué Origano mat. Robinetterie Flow en acier inox satiné avec cartouche traditionnelle. | Untergestell mit lotrechter Gehrung und Lackoberfläche im Farbton Origano Matt mit Waschbecken Man 126 aus Cristalplant. Spiegel Vetra, Dicke 2,8 cm, mit LED-Hintergrundbeleuchtung oben und unten auf den beiden Seiten. Hängeschränke mit Tür und 45° Abkantung mit Lackoberfläche in Origano Matt. Wasserhähne Flow aus satiniertem Edelstahl mit traditionelle Kartusche. | Тумба с центральным пазом в матовом лаке Origano с раковиной Man 126 из Cristalplant. Зеркало Vetra толщ. 2,8 см с подсветкой из светодиодов с двух сторон, верхней и нижней. Навесные шкафы со створкой с фаской 45° с отделкой в матовом лаке Origano. Смесители Flow из сатинированной нержавеющей стали с прогрессивным картриджем.





ZENIT 19.06

Rovere Carbone

Bianco

Cristalplant

144 x 48 x 47 cm

56 3/4" x 18 7/8" x 18 1/2"



Base con gola superiore in poro Rovere Carbone con lavabo Man 144 e vassoio in Cristalplant. Specchiera Klose con anta girevole in laccato Bianco opaco e specchio ingranditore. Rubinetteria Flow in acciaio inox satinato con cartuccia tradizionale. | Open pore Rovere Carbone base unit with upper groove, with Man 144 washbasin and tray in Cristalplant. Klose mirror with Bianco lacquered revolving door and magnifying mirror. Flow taps in brushed stainless steel, with traditional cartridge. | Base avec gorge supérieure en Poro Rovere Carbone avec lavabo Man 144 et plateau en Cristalplant. Miroir Klose avec porte pivotante en laqué Bianco mat et miroir grossissant. Robinetterie Flow en acier inox satiné avec cartouche traditionnelle. | Unterbau mit oberer Gehrung in offenporiger Rovere im Farbton Carbone mit Waschbecken Man 144 und Becken aus Cristalplant. Spiegel Klose mit drehbarer Tür und Lackoberfläche in Bianco Matt sowie Vergrößerungsspiegel. Wasserhähne Flow aus satinierterem Edelstahl mit traditioneller Kartusche. | Тумба с верхним пазом из пористого дуба Rovere Carbone с раковиной Man 144 и поддоном из Cristalplant. Зеркало Klose с поворотной створкой в белом матовом лаке, с увеличительным зеркалом. Смесители Flow из satinированной нержавеющей стали с традиционным картриджем.





ZENIT 19.07

Caffè  
Cristalplant  
198 x 24 x 47 cm  
78" x 9 1/2" x 18 1/2"

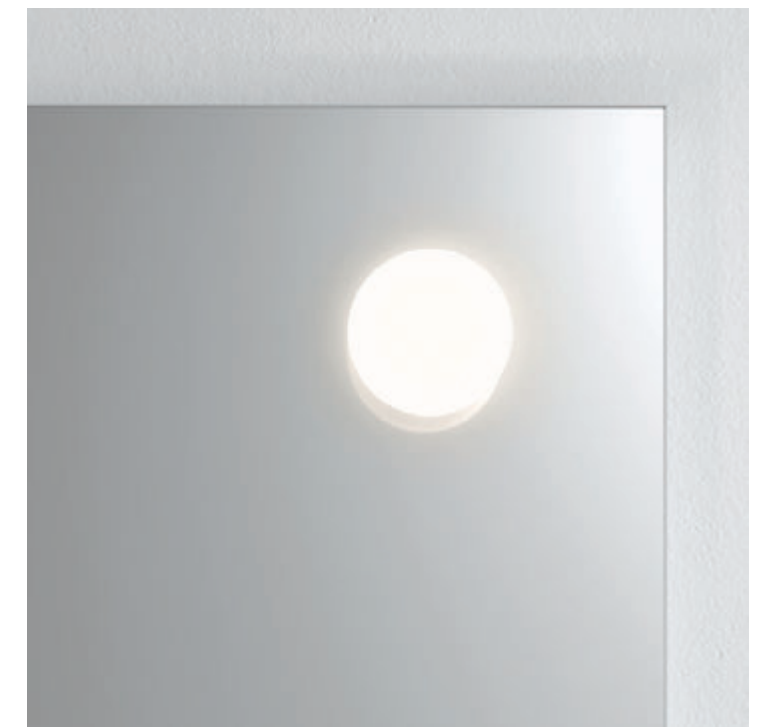

Lavabo Man 126 e vassoio in Cristalplant. Basi con gola superiore in laccato Caffè opaco. Pensili con anta a 45° in laccato Caffè opaco. Specchiera Vetra sp. 2,8 cm. Lampada Moon a LED. Rubinetteria Flow in acciaio inox satinato con cartuccia progressiva. | Lavabo Man 126 washbasin and tray in Cristalplant. Matt Caffè lacquered base units with upper groove. Matt Caffè lacquered wall units with 45° door. Vetra mirror, th. 2.8 cm Moon LED lamp. Flow taps in brushed stainless steel, with progressive cartridge. | Lavabo Man 126 et plateau en Cristalplant. Bases avec gorge supérieure en laqué Caffè mat. Meubles hauts avec porte à 45° en laqué Caffè mat. Miroir Vetra ép. 2,8 cm. Lampe Moon à LED. Robinetterie Flow en acier inox satiné avec cartouche progressive. | Waschbecken Man 126 und Becken aus Cristalplant. Unterbauten mit oberer Gehrung und Lackoberfläche im Farbton Caffè Matt. Hängeschränke mit Tür und 45° Abkantung mit Lackoberfläche in Caffè Matt. Spiegel Vetra Dicke 2,8 cm. LED-Leuchte Moon. Wasserhähne Flow aus satiniertem Edelstahl mit progressive Kartusche. Раковина Man 126 и поддон из Cristalplant. Тумбы с верхним пазом с отделкой в матовом лаке Caffè. Навесные шкафы со створкой с фаской 45° в матовом лаке Caffè. Зеркало Vetra толщ. 2,8 см. Светодиодная лампа Moon. Смесители Flow из satinированной нержавеющей стали с прогрессивным картриджем.



# Azuma Collection

design by Lievore Altherr

Una proposta che reinterpreta l'estetica del bagno giapponese, una dimensione di grande fascino evocativo in cui la principale fonte d'ispirazione è la natura. Così i lati dei lavabi e della vasca, come una goccia d'acqua che cade, si evolvono dalla circolarità della parte superiore al quadrato delle basi. Mentre i piani d'appoggio della vasca ricordano i ciottoli levigati dall'acqua, gli sgabelli sono volumi essenziali come le rocce in un giardino zen. Forme fluide, semplici solo in apparenza e sempre attuali perché ispirate a un linguaggio senza tempo.

A solution that reinterprets the aesthetics of the Japanese bathtub, a size with a highly evocative charm whose main source of inspiration is nature. The sides of the washbasins and the bathtub, like a drop of water falling down, evolve from the circularity of the top to the square bases. While the supporting surfaces of the bathtub recall pebbles polished by water, the stools are essential volumes like the rocks of a zen garden. Fluid shapes that only appear to be simple and are always modern, as they draw inspiration from a timeless language.

Une proposition qui réinterprète l'esthétique de la salle de bain japonaise, une dimension au charme évocateur qui s'inspire principalement de la nature. Les parois des vasques et de la baignoire, tout comme une goutte d'eau qui tombe, partent des rondeurs de la partie supérieure jusqu'au carré de la base. Alors que les plans d'appui de la vasque rappellent des pierres polies par l'eau, les tabourets sont des volumes essentiels comme les rochers d'un jardin zen. Des formes fluides, avec un aspect simple mais actuel car s'inspirant d'un langage intemporel.

Ein Vorschlag, der die Ästhetik des japanischen Bades wieder aufnimmt, mit faszinierenden Abmessungen, wobei die Natur die bedeutendste Quelle der Inspiration ist. So verwandeln sich die Ränder von Waschbecken und Wanne – wie Wassertropfen, die zur Erde fallen – aus der runden Form des oberen Teil in die viereckige Form des Unterteils. Die Ablageflächen der Wanne erinnern dagegen an vom Wasser glatt geschliffene Kieselsteine, die Hocker erinnern in ihrer Schlichtheit an Felsen in einem Zen-Garten. Fließende Formen, die nur dem Anschein nach einfach sind; immer aktuell, da sie sich durch Zeitlosigkeit haben inspirieren lassen.

Это предложение по-новому интерпретирует эстетику японской ванной комнаты и воскрещает в памяти все очарование традиций, черпая вдохновение, главным образом, в природе. Стенки раковин и ванн, как падающая капля воды, меняют круглую форму в верхней части на квадратную форму в основании. Опорные поверхности ванны напоминают отшлифованные водой камни, а табуреты являют собой аналог камням в японском саду дзен. Гладкие, простые лишь на первый взгляд, формы, всегда актуальны, поскольку являются воплощением языка самовыражения, неподвластного времени.



## AZUMA 19.01

Rovere Miele  
Cristalplant  
Rovere Carbone  
sughero | cork  
252 x 16 x 51 cm  
99 1/4" x 6 1/4" x 20 1/8"

Lavabo in appoggio Azuma 58 in Cristalplant. Top sospeso con cassetti a folding in Rovere Miele. Panca Zen con listelli in Rovere Miele. Specchio Air con retroilluminazione a LED. Vasca Azuma a parete con portarubinetti in Cristalplant, vassoi Loto in Rovere Carbone. Paravento Levante a due ante, a specchio e listelli in Rovere Miele o anta rivestita in tessuto finitura Sesamo. Sedia serie Toro in Rovere Carbone. Appendino a parete serie Toro in Rovere Miele. Pouff Maki in sughero nero.

Azuma 58 Cristalplant sit-on washbasin. Wall-hung top with Rovere Miele folding processing drawers. Zen bench with Rovere Miele strips. Air mirror with LED backlight. Azuma wall-mounted bathtub with Cristalplant tap holder, Loto Rovere Carbone trays. Levante two panels mirrored screen, with Rovere Miele strips or Sesamo finish fabric upholstered panel. Toro series Rovere Carbone chair. Toro series Rovere Miele wall-mounted coat rack. Black cork Maki pouf.

Lavabo à poser Azuma 58 en Cristalplant. Plan suspendu avec tiroirs à folding en Rovere Miele. Banquette Zen avec plinthes en Rovere Miele. Miroir Air avec rétroéclairage à LED. Baignoire Azuma murale avec porte-robinets en Cristalplant, plateaux Loto en Rovere Carbone. Paravent Levante à deux portes, à miroir et plinthes en Rovere Miele ou porte revêtue tissu finition Sesamo. Chaise série Toro en Rovere Carbone. Porte-manteau mural série Toro en Rovere Miele. Pouf Maki en liège noir.

Auflagewaschbecken Azuma 58 aus Cristalplant. Hängende Platte mit Klappschubladen aus Rovere im Farbton Miele. Bank Zen mit Leisten aus Rovere im Farbton Miele. Spiegel Air mit LED-Hintergrundbeleuchtung. Wanne Azuma an der Wand mit Armaturenhalter aus Cristalplant. Becken Loto aus Rovere im Farbton Carbone. Freistehende spanische Wand Levante mit zwei Flügeln, Spiegel und Leisten aus Rovere im Farbton Miele oder Flügel mit einer Verkleidung aus Stoff und Oberflächenausführung im Farbton Sesamo. Stuhl aus der Serie Toro aus Rovere im Farbton Carbone. Wandaufhänger aus der Serie Toro aus Rovere im Farbton Miele. Puff Maki aus schwarzem Kork.

Накладная раковина Azuma 58 из Cristalplant. Подвесная столешница с ящиками, изготовленными методом складывания, из дуба Rovere Miele. Скамья Zen с рейками из дуба Rovere Miele. Зеркало Air со светодиодной подсветкой. Ванна Azuma пристенная с держателями для смесителей из Cristalplant, поддонами Loto из дуба Rovere Carbone. Двустворчатая зеркальная ширма Levante с рейками из дуба Rovere Miele или со створками с обивкой тканью Sesamo. Стул серии Toro из дуба Rovere Carbone. Настенная вешалка серии Toro из дуба Rovere Miele. Пуф Maki из чёрной пробки.



























AZUMA 19.02

Cristalplant  
 Rovere Mezza Fiamma  
 Ø 44,6 x 88 cm  
 Ø 17 1/2" x 34 5/8"



Monolite a terra Azuma 88 in Cristalplant. Paravento Levante a due ante, a specchio e listelli in Rovere Mezza Fiamma. Portasciugamano da terra serie Toro in Rovere Mezza Fiamma. Rubinetteria Flow in acciaio inox satinato con cartuccia tradizionale. | Azuma 88 Cristalplant monolith unit. Levante two panel mirrored screen, with Rovere Mezza Fiamma strips. Toro Rovere Mezza Fiamma floor-mounted towel rack. Flow taps in brushed stainless steel, with traditional cartridge. | Monolithe sur pied Azuma 88 en Cristalplant. Paravent Levante à deux portes, à miroir et plinthes en Rovere Mezza Fiamma. Porte-serviette sur pied série Toro en Rovere Mezza Fiamma. Robinetterie Flow en acier inox satiné avec cartouche traditionnelle. | Monolith Standwaschbecken Azuma 88 aus Cristalplant. Freistehende spanische Wand Levante mit zwei Flügeln, Spiegel und Leisten aus Rovere im Farbton Mezza Fiamma. Handtuchständer aus der Serie Toro aus Rovere im Farbton Mezza Fiamma. Wasserhähne Flow aus satiniertem Edelstahl mit traditioneller Kartusche. | Напольный монолит Azuma 88 из Cristalplant. Двухстворчатая зеркальная ширма с рейками из дуба Rovere Mezza Fiamma. Напольный полотенцедержатель серии Toro из дуба Rovere Mezza Fiamma. Смесители Flow из сатирированной нержавеющей стали с традиционным картриджем.



Cristalplant  
 Rovere Carbone  
 sughero | cork  
 Ø 44,6 x 88 cm  
 Ø 17 1/2" x 34 5/8"

Monolite a terra Azuma 88 in Cristalplant. Appendino da terra serie Toro in Rovere Carbone. Portasciugamano da terra serie Toro in Rovere Carbone. Pouff Maki in sughero naturale e nero. Specchiera Air con retroilluminazione a LED. Rubinetteria Flow in acciaio inox satinato con cartuccia tradizionale.

Azuma 88 Cristalplant monolith unit. Toro series Rovere Carbone floor-mounted coat rack. Toro Rovere Carbone floor-mounted towel rack. Natural black cork Maki pouf. Air mirror with LED backlight. Flow taps in brushed stainless steel, with traditional cartridge.

Monolithe sur pied Azuma 88 en Cristalplant. Porte-manteau sur pied série Toro en Rovere Carbone. Porte-serviette sur pied série Toro en Rovere Carbone. Pouf Maki en liège naturel et noir. Miroir Air avec rétroéclairage à LED. Robinetterie Flow en acier inox satiné avec cartouche traditionnelle.

Monolith Standwaschbecken Azuma 88 aus Cristalplant. Wandaufhänger aus der Serie Toro aus Rovere im Farbton Carbone. Handtuchständer aus der Serie Toro aus Rovere im Farbton Carbone. Puff Maki aus naturfarbenem und schwarzem Kork. Spiegel Air mit LED-Hintergrundbeleuchtung. Wasserhähne Flow aus satiniertem Edelstahl mit traditioneller Kartusche.

Напольный монолит Azuma 88 из Cristalplant. Напольная вешалка серии Toro из дуба Rovere Carbone. Напольный полотенцедержатель серии Toro из дуба Rovere Carbone. Пуф Maki из натуральной и черной пробки. Зеркало Air со светодиодной подсветкой. Смесители Flow из сатинированной нержавеющей стали с традиционным картриджем.













# Roma Collection

design by Lievore Altherr

Evidente nella collezione Roma l'ispirazione al mondo classico e alla sua architettura. Protagonista è quindi la pietra che con diverse venature, cromie e lavorazioni superficiali caratterizza un lavabo verticale cilindrico e una vasca stondata. Una serie di monoliti dalle forme purissime e altamente espressive accompagnata da specchiere singole o a coppia, pensate come quinte, originali elementi di una scenografia domestica da creare in libertà. Degli essenziali portasciugamani free standing di metallo che riprendono le forme curve degli specchi e più in generale di tutta la serie completano la collezione.

The Roma collection is clearly inspired from the classical world and its architecture. The limelight is therefore on stone, which with different veins, colours and surface finishes is featured on a vertical cylindrical washbasin and a rounded bathtub. A series of extremely pure and highly expressive monoliths with single or double mirrors, conceived like the wings of a theatre, original elements of a domestic setting to be freely defined. Essential metal free-standing towel racks that resemble the curved design of mirrors and, more in general the design of the whole the series, complete the collection.

Dans la collection Roma l'inspiration au monde classique et à son architecture est évidente. Le protagoniste est donc la pierre qui avec différents veinages, couleurs et traitements superficiels caractérise une vasque verticale cylindrique et une baignoire arrondie. Une série de monolithes aux formes très pures et extrêmement expressives accompagnée de miroirs simple ou doubles, pensés comme des coulisses, des éléments originaux d'un décor domestique à créer librement. Des porteserviettes free standing en métal qui rappellent les formes arrondies des miroirs et plus en général toute la série complètent la collection.

Ganz deutlich ist bei der Kollektion Roma der Einfluss der klassischen Welt und ihrer Architektur. Mittelpunkt ist der Stein, der mit verschiedenen Äderungen, Farbnuancen und berflächenbearbeitungen das vertikale, zylindrische angelegte Waschbecken und die abgerundete Wanne kennzeichnet. Eine Reihe von Monolithen reinster Formen und mit großer Ausdruckskraft, dazu einzelne oder paarweise Standspiegel, die als Kulissen gedacht sind, originelle Elemente auf der häuslichen Bühne, die frei zusammengestellt werden können. Dazu absolut schlichte, freistehende Handtuchhalter aus Metall, welche die runden Formen der Spiegel und, allgemeiner, der gesamten Serie wieder aufnehmen und die Kollektion vervollständigen.

В коллекции Roma очевидны черты классического стиля и архитектуры. Главным элементом является камень, различные прожилки, тона и виды поверхностной обработки которого характеризуют вертикальную цилиндрическую раковину и ванну с закругленными углами. Ряд монолитных элементов отличается простотой и выразительностью форм, сочетается с отдельными или парными зеркалами, напоминающими ширмы - оригинальные компоненты свободно создаваемых домашних декораций. Завершают коллекцию металлические минималистские вешалки для полотенца в виде стоек, которые повторяют изогнутые линии, характеризующие зеркала и, в целом, всю коллекцию.



ROMA 19.01

Bianco Carrara  
Grafite  
Ø 45 x 88 cm  
Ø 17 3/4" x 34 5/8"

Monolite a terra Roma III con lavabo liscio in marmo Bianco Carrara, parte inferiore con fresatura irregolare in marmo Grafite. Vasca Roma in marmo Bianco Carrara, zoccolo con fresatura irregolare in marmo Grafite. Porta salviette Roma verniciato nero. Serie specchi Roma free-standing con profilo verniciato nero e anta luminosa.

Roma III floor-mounted monolith unit with smooth Bianco Carrara marble washbasin, Grafite marble bottom with irregular milling. Roma Bianco Carrara marble bathtub, Grafite marble plinth with irregular milling. Roma black painted towel holder. Roma free-standing mirror series with black painted profile and door with fitted lights.

Monolithe sur pied Roma III avec lavabo lisse en marbre Bianco Carrara, fraisage irrégulier au bas en marbre Grafite. Baignoire Roma en marbre Bianco Carrara, socle avec fraisage irrégulier en marbre Grafite. Porte-serviettes Roma vernis noir. Série miroirs Roma free-standing avec profil vernis noir et porte lumineuse.

Monolith Standwaschbecken Roma III mit glattem Waschbecken aus weißem Carrara-Marmor, unterer Teil mit unregelmäßiger Fräsung aus Marmor im Farbton Grafite. Wanne Roma aus weißem Carrara-Marmor, Sockel mit unregelmäßiger Fräsung aus Marmor im Farbton Grafite. Handtuchstange Roma, schwarz lackiert. Spiegelserie Roma, free-standing, mit schwarz lackiertem Profil und beleuchteter Tür.

Напольный монолит Roma III с гладкой раковиной из мрамора Bianco Carrara, нижняя часть с неровной фрезерной обработкой из мрамора Grafite. Ванна Roma из мрамора Bianco Carrara, цоколь с неровной фрезерной обработкой из мрамора Grafite. Полотенцедержатель Roma окрашенный черной краской. Серия отдельно расположенных зеркал Roma с окрашенным черным профилем и створкой с подсветкой.



















1. Roma IV: Moka Cream, Grafite, Ardesia
2. Roma III: Moka Cream, Moka Cream
3. Roma IV: Carrara, Carrara, Carrara
4. Roma III: Carrara, Moka Cream
5. Roma III: Grafite, Moka Cream
6. Roma IV: Carrara, Moka Cream, Ardesia
7. Roma III: Moka Cream, Carrara

#### Roma III

lavabo liscio in marmo, parte inferiore con fresatura irregolare in marmo | smooth marble washbasin, marble bottom with irregular milling | lavabo lisse en marbre, partie inférieure avec fraisage irrégulier en marbre | Glattes Waschbecken aus Marmor, unterer Teil mit unregelmäßiger Fräsung aus Marmor | гладкая раковина из мрамора, нижняя часть с неровной фрезерной обработкой из мрамора

#### Roma IV

Lavabo liscio in marmo, parte centrale con fresatura irregolare in marmo, zoccolo a spacco in pietra Ardesia o zoccolo liscio in marmo | smooth marble washbasin, marble central part with irregular milling stone, cleft finish plinth in Ardesia or smooth marble plinth | vasque lisse en marbre, partie central avec fraisage irrégulier en marbre, socle fendu en pierre Ardesia ou lisse en marbre | Glattes Waschbecken aus Marmor, Mittelteil mit unregelmäßiger Fräsung aus, Sockel mit Spalt aus Schiefer Ardesia oder glatter Sockel aus Marmor | гладкая раковина из мрамора, центральная часть с неровной фрезерной обработкой из мрамора, цоколь с рваными краями Ardesia или гладкий цоколь из мрамора



ROMA 19.03

ceramica | ceramic  
oro satinato | brushed gold  
Noce Canaletto  
Rovere Nero  
Titanio  
Ø 45 x 88 cm  
Ø 17 3/4" x 34 5/8"

Monolite a terra Roma II con lavabo in ceramica nera opaca, fascia finitura oro satinato, parte centrale in Noce Canaletto e zoccolo in Rovere Nero. Mensola Ljos in alluminio laccato Titanio, completa di accessori e retroilluminazione a LED. Specchiera Air con retroilluminazione a LED.

Roma II floor-mounted monolith unit with matt black ceramic washbasin, strip in brushed gold finish, Noce Canaletto central part and Rovere Nero plinth. Ljos shelf made of Titanio finish lacquered aluminium, complete with accessories and LED backlight. Air mirror with LED backlight.

Monolithe sur pied Roma II avec lavabo en céramique noire mate, bande en finition oro satinato, partie centrale en Noce Canaletto et socle en Rovere Nero. Étagère Ljos en aluminium laqué Titanio, pourvue d'accessoires et rétroéclairage à LED. Miroir Air avec rétroéclairage à LED.

Monolith Standwaschbecken Roma II mit Waschbecken aus mattschwarzer Keramik, Band mit Oberflächenausführung aus satiniertem Gold, Mittelteil aus Noce Canaletto und Sockel aus Rovere Nero. Ablagefläche Ljos aus Aluminium mit Lackoberfläche im Farbton Titanio, komplett mit Zubehör und LED-Hintergrundbeleuchtung. Air Spiegel mit LED-Hintergrundbeleuchtung.

Напольный монолит Roma II с раковиной из черной матовой керамики, полоса с отделкой сатинированного золота, центральная часть из ореха Noce Canaletto и цоколь из дуба Rovere Nero. Полка Ljos из лакированного алюминия Titanio в комплекте с аксессуарами и светодиодной подсветкой. Зеркало Air со светодиодной подсветкой.











1. Roma II: ceramica nera | black ceramic, oro satinato | brushed gold, Noce Canaletto, Rovere Nero
2. Roma II: ceramica bianca | white ceramic, Platino, Rovere Mezza Fiamma, Rovere Nero
3. Roma I: ceramica nera | black ceramic, oro satinato | brushed gold, Noce Canaletto
4. Roma I: ceramica bianca | white ceramic, Platino, Rovere Nero
5. Roma I: ceramica bianca | white ceramic, Platino, Rovere Mezza Fiamma
6. Roma I: ceramica nera | black ceramic, oro satinato | brushed gold, Rovere Nero
7. Roma II: ceramica bianca | white ceramic, Platino, Noce Canaletto, Rovere Nero

#### Roma I

lavabo in ceramica opaca, fascia, parte inferiore in essenza | matt ceramic washbasin, strip, lower part in veneer | vasque en matte céramique, bande, partie inférieure en essence | Waschbecken aus matt Keramik, Band, unterer Teil aus schwarzer Holz | раковина из черной матовой керамики, полоса, нижняя часть из ореха

#### Roma II

lavabo in ceramica opaca, fascia, parte inferiore in essenza, zoccolo in Rovere Nero | matt ceramic washbasin, strip, lower part in veneer, plinth in Rovere Nero | vasque en matte céramique, bande, partie inférieure en essence, socle en Rovere Nero | Waschbecken aus matt Keramik, Band, unterer Teil aus schwarzer Holz, Sockel aus Rovere Nero | Раковина из черной матовой керамики, полоса, нижняя часть из ореха, цоколь из Rovere Nero





## Talking with *Jeannette Altherr*

Alberto Lievore (Buenos Aires, 1948) e Jeannette Altherr (Heidelberg, 1965) iniziano un nuovo percorso nel 2016 dopo un'attività di 25 anni come studio Lievore Altherr Molina. Lo studio, con sede a Barcellona, è specializzato nella progettazione di prodotti e il loro sviluppo, consulenza strategica, direzione creativa, direzione artistica e architettura per aziende di design riconosciute a livello internazionale.

Alberto Lievore (Buenos Aires, 1948) and Jeannette Altherr (Heidelberg, 1965) start a new path in 2016 after a 25 year trajectory as Lievore Altherr Molina. The Barcelona-based studio specializes in product design and development, strategic consulting, creative direction, art direction, and ephemeral architecture for internationally recognized design companies.



“The bathroom is no longer just a functional space but also the representation of one’s tastes and a place to relax.”

*Noorth è un nuovo brand. Esiste una affinità tra la filosofia dello studio e la visione dell’arredo bagno che si prefigura di interpretare l’azienda?*

Discutendo con il cliente, abbiamo compreso che il nome Noorth non deriva dalla volontà di evocare una certa cultura o un paese specifico, ma da un’idea di armonia e purezza che in qualche modo lega diversi paesi e culture. Lo stesso vale per la semplicità e la luminosità, che richiamano l’essenzialità che è presente nel nostro studio multietnico sin dai suoi albori.

*Azuma e Roma sono due collezioni per l’ambiente bagno che esprimono una estetica molto diversa.*

*Cosa hanno in comune?*

Con le nostre due collezioni Noorth abbiamo analizzato due approcci diversi: uno pensato per la vita di tutti i giorni (Azuma) e l’altro concepito più come un elemento speciale e di lusso (Roma). Azuma è stata pensata per sostenerci in modo delicato e gentile nelle attività di ogni giorno. I materiali sono caldi e accoglienti, e nessun momento viene trascurato. Roma è un elemento che crea un’atmosfera speciale; è sinonimo di celebrazione, esclusività; sottolinea un senso di eleganza e al contempo di solidità. È una piccola fantasia, una mini fuga, un rituale. In comune hanno i materiali e le associazioni che ci suggeriscono. Il comune denominatore delle due collezioni è l’equilibrio del calore. Per Azuma, come descritto nel “Libro d’ombra” di Junichiro Tanizaki, ci siamo avvicinati all’idea del bagno inteso come ambiente morbido, caldo, non troppo luminoso, in penombra. Abbiamo usufruito delle caratteristiche tecniche del Milltek, materiale

*Noorth is a new brand. Is there any affinity between the philosophy of the studio and the vision of the bathroom furnishings that the company is pursuing?*

While discussing with the customer, we understood that the name Noorth does not derive from the desire to evoke a certain culture or a specific country, but from an idea of harmony and purity that in some way links different countries and cultures. The same goes for simplicity and brightness, which recall the essentiality that is present in our multi-ethnic studio since its beginnings.

*Azuma and Roma are two bathroom collections that express a very different aesthetic. What do they have in common?*

With our two Noorth collections we analysed two different approaches: one designed for everyday life (Azuma) and the other conceived more as a special, luxurious element (Roma). Azuma was designed to provide us with delicate and gentle support in our everyday activities. The materials are warm and welcoming, and no moment is neglected. Roma creates a special atmosphere; it is synonymous with celebration, exclusivity; it underlines a sense of elegance and strength at the same time. It’s a little fantasy, a mini escape, a ritual. They share the materials and the associations that they suggest to us. The common denominator of the two collections is the balance of heat. For Azuma, as described in “In Praise of Shadows” by Junichiro Tanizaki, we approached the idea of the bathroom as a soft, warm, not too luminous environment, in the half-light. We have exploited the technical features of Milltek, a white, smooth and “abstract” material that we can call “cold” and

bianco, liscio e “astratto” che possiamo definire “freddo” e lo abbiamo unito ad accessori in legno, quali i divisori di spazio ispirati alle tradizionali porte scorrevoli giapponesi, piccoli sgabelli e appendiabiti. La collezione Roma si basa invece sulla pietra e per questa linea ci siamo ispirati alla cultura mediterranea. La pietra ha qualcosa di nobile e di nuovo scegliamo di interpretarla in modo caldo, non freddo e lucido marmo ma utilizzando una texture più opaca, unendo diversi colori e texture per ottenere una composizione forte e decisa.

*Che valore ha l’ambiente bagno nella casa contemporanea?*

I confini tra le varie parti della casa oggi svaniscono, si fondono. La cucina diventa un posto per accogliere gli amici e trascorrere del tempo, il salotto un posto per lavorare e il bagno non è più solo uno spazio funzionale ma anche la rappresentazione dei propri gusti e un posto in cui rilassarsi. Pensiamo quindi che debba essere il luogo nel quale identificarsi e sentirsi sicuri e protetti, persino più che altrove.

*Come vi immaginate l’evoluzione dell’idea di “lusso” in un panorama internazionale nel prossimo futuro?*

L’idea del lusso legata ad oggetti costosi appartiene ormai al passato. La ricchezza non è possedere ma avere il tempo di godersi le cose. Il lusso di oggi è più una questione di possibilità di vivere esperienze, di poter decidere di essere responsabile del tuo corpo, di poter scegliere l’ambiente in cui vivere. Lo stesso vale per la disponibilità di spazio e tempo per godersi la vita.

we have combined it with wooden accessories, such as partitions inspired by traditional Japanese sliding doors, small stools and hangers. The Rome collection is based on stone; for this line we drew our inspiration from the Mediterranean culture. The stone has something noble; once more, we choose to interpret it in a warm way, not as cold and polished marble but using a more opaque texture, combining different colours and textures for a strong and clean composition.

*How much importance is attributed to the bathroom in contemporary homes?*

Nowadays, the boundaries between the various areas of the house disappear and merge. The kitchen becomes a place to welcome friends and spend time, the living room turns into a working space, and the bathroom is no longer just a functional space but also the representation of one’s tastes and a place to relax. As a result, we think that it should be the place where one can rediscover one’s self and feel safe and protected, even more than anywhere else.

*How do you imagine the evolution of the idea of “luxury” in an international scenario in the near future?*

The idea of luxury linked to expensive objects now belongs to the past. Wealth is not about possessions but about having the time to enjoy things. Today’s luxury is more a question of the possibility to experience, to be able to decide, to be responsible for your own body, to be able to choose the environment where you want to live. The same applies to the availability of space and time to enjoy life.







“Azuma was designed to provide us with delicate and gentle support in our everyday activities. The materials are warm and welcoming, and no moment is neglected.”

*Il vostro linguaggio progettuale risulta molto preciso e riconoscibile. Come lo definireste?*

Siamo alla ricerca di un approccio olistico su diversi fronti: per chi? Perché? Come? Cerchiamo sempre di intrecciare i diversi fili che compongono un progetto: ispirazioni, identità del produttore e le sue necessità, i bisogni e i desideri dei possibili acquirenti. Non pensiamo che il nostro lavoro abbia uno stile specifico o un unico linguaggio espressivo, è più che altro la sintesi di molti livelli uniti in un'unica forma. Ricerchiamo armonia ed equilibrio, valori in cui crediamo.

*Come si sviluppa un progetto nel vostro studio? Esiste una metodologia definita, costante?*

Solitamente non è il solo lavoro sul design di un prodotto, ma più che altro è progettare una strategia di design per un'intera collezione o addirittura per una compagnia. Ognuno di noi ha poi il proprio metodo di lavoro. Può essere una “moodboard” che illustri un'idea o un'atmosfera; possono essere precise analisi di mercato per capire su cosa puntare; può essere una critica sulla comunicazione attuale; può essere un consiglio diretto al produttore. Ad un certo punto tutti questi aspetti si uniscono. La presentazione al produttore dei disegni e dei render è lo step successivo, si esplorano dettagli e proporzioni, prototipi, correzioni e altre correzioni: è un processo piuttosto lungo. Sono molto importanti continui e costanti confronti del progetto in relazione all'ambiente che occuperanno. Colori e finiture poi possono davvero definire un prodotto, permettendogli di raccontare una specifica storia che è in seguito tradotta in testi

*Your design language is very precise and recognisable. How would you define it?*

We are looking for a holistic approach on various fronts: for whom? Why? How? We always try to weave the different threads that make up a project: inspirations, identity of the producer and its needs, the needs and desires of possible buyers. We do not think that our work has a specific style or a single expressive language, it is more a synthesis of many levels merged in one form. We look for harmony and balance, values in which we believe.

*How do you develop a project in your studio? Is there a defined, constant methodology?*

Usually it is not just about the work on the design of a product; rather it is about coming up with a design strategy for an entire collection or even for a company. We then all follow our own working method. It can be a “mood board” that illustrates an idea or an atmosphere; they can be precise market analyses to understand what to aim for; it can be a criticism of current communication; it can be a direct piece of advice to the producer. At some point all these aspects come together. The next step is the presentation to the producer of drawings and renderings, exploring details and proportions, prototypes, corrections and more corrections: it is a rather long process. Very important are the continuous and constant comparisons of the project with the environment it will occupy. Colours and finishes can really define a product, allowing it to tell a specific story that is later translated into texts and images. This is a work we do on the image of each product, a work performed in the studio or on site: we must

“Roma creates a special atmosphere; it is synonymous with celebration, exclusivity; it underlines a sense of elegance and strength at the same time.”

e immagini. Questo è un lavoro che facciamo sull'immagine di ogni prodotto, lavoro fatto in studio o in location: dobbiamo comprenderne l'utilizzo, la forma, il dettaglio. Infine c'è la sua presentazione nello stand fieristico.

*Quanto è importante il rapporto con l'azienda per la nascita di un buon prodotto?*

Un buon rapporto con l'azienda è la base per ottenere un buon risultato. La fase progettuale è molto complessa e qualcosa può andare storto in qualsiasi momento. Capita quando non si parla con gli stessi codici, oppure quando non si ha una visione simile riguardo lo sviluppo di un progetto. Solamente se designer e compagnia collaborano si può ottenere un prodotto di successo.

understand its use, form and detail. Finally there is presentation of the project on the exhibition stand.

*How important is the relationship with the company for the creation of a good product?*

A good relationship with the company is the basis for achieving a good result. The design phase is very complex and things can go wrong at any time. It happens when we are not on the same page or when we do not have a similar vision about the development of a project. A successful product is guaranteed only if the designer and the company work together.







# Touch Collection

design by Michele Marcon

Un lavabo monolitico dall'estetica minimale capace di conferire identità e personalità anche a spazi di piccole dimensioni. Touch stupisce per l'estrema compattezza che nasconde una straordinaria funzionalità ma anche per l'ampia varietà di finiture che impreziosiscono le sue superfici: dalle laccature, alle essenze naturali, fino alle argille. Una proposta dall'impronta contemporanea, dal forte valore scultoreo accentuato dalla combinazione con le specchiere dotate di illuminazione led integrata.

A versatile and transversal solution allowing for utmost freedom of composition, thanks to a wide range of elements and accessories, all featuring uncompromising stylistic rigor and three types of door opening systems: handle, now also available in a lacquered version, groove or push-pull. From the backlit mirrors with shelves to integrated or stand-alone washbasin units in different shapes and with thin edges, from the surface tops in fine materials to containers with different layouts and a mix of closed or open-fronted units, all made with unique and environmentally friendly materials.

Cette riche gamme de modèles a pour fil conducteur le minimalisme et la rigueur géo-métrique. Elle se distingue par ses produits contemporains, notamment ses lavabos à poser aux bords fins qui en plus de conférer une touche de légèreté et d'élégance. Dans les autres types d'installation disponibles, la gamme comprend également des lavabos encastrables ou à poser repropoant des formes classiques ou explorant des configurations inédites à travers une vaste palette de matériaux allant des matières naturelles - comme les marbres ou les céramiques - aux matières synthétiques de nouvelle génération.

Eine breitgefächerte Auswahl an Modellen, durch die sich als roter Faden eine strenge geometrische Linienführung und ein sich aufs Wesentliche beschränkendes, schnörkelloses Erscheinungsbild ziehen. Es sind zeitgenössische Lösungen, die in Form von aufliegenden Waschbecken mit dünnem Beckenabschluss nicht nur das Bild von eleganter Leichtigkeit vermitteln. Die Montage sieht unter anderem integrierte Waschbecken, aber auch aufliegende Waschbecken vor, die einerseits klassische Formen wieder aufnehmen, andererseits mit Hilfe einer Vielzahl von Materialien, so zum Beispiel Marmor und Keramik, aber auch synthetischen Materialien neuester Machart, mit neuen Gestaltungs- und Anordnungsmöglichkeiten experimentieren.

Обширный диапазон моделей, отличающихся общей геометрической строгостью и простотой. Современные модели устанавливаемых на поверхность раковин с тонкими краями, создающих ощущение утонченной легкости и дополнительно увеличивающих объем. Гамма изделий включает встроенные или установленные на поверхность раковины, воспроизводящие классические формы или создающие новые необычные конфигурации, используя широкий спектр материалов, от самых натуральных, таких как мрамор и керамика, до синтетических и новых материалов.



## TOUCH 19.01

Grafite, marmo | marble  
Quarzo  
100 x 88 x 40 cm  
39 3/8" x 34 5/8" x 15 3/4"

Base predisposta per scarico a pavimento con lavabo Full 100 in marmo Grafite. Specchiera Ekos V con illuminazione a LED quattro lati interni, profilo in alluminio laccato Quarzo. Mensole Ljos in alluminio laccato Quarzo, complete di accessori e retroilluminazione a LED. Rubinetteria Flow in acciaio inox satinato con cartuccia tradizionale.

Floor drain base unit with Full 100 Grafite marble washbasin. Ekos V mirror unit with all-round LED interior lighting, Quarzo finish lacquered aluminium profile. Ljos shelves in Quarzo finish lacquered aluminium, complete with accessories and LED backlight. Flow taps in brushed stainless steel, with traditional cartridge.

Base prévue pour évacuation au sol avec lavabo Full 100 en marbre Grafite. Miroir Ekos V avec éclairage à LED quatre côtés internes, profil en aluminium laqué Quarzo. Étagères Ljos en aluminium laqué Quarzo, pourvues d'accessoires et rétroéclairage à LED. Robinetterie Flow en acier inox satiné avec cartouche traditionnelle.

Für Bodenablauf vorgerüsteter Unterbau mit Waschbecken Full 100 aus Grafite-Marmor. Wandspiegel Ekos V mit vierseitiger LED-Hintergrundbeleuchtung, Profil aus Aluminium mit Lackoberfläche im Farbton Quarzo. Ablageflächen Ljos aus Aluminium mit Lackoberfläche im Farbton Quarzo, komplett mit Zubehör und LED-Hintergrundbeleuchtung. Wasserhähne Flow aus satiniertem Edelstahl mit traditioneller Kartusche.

Тумба со сливом в пол с раковиной Full 100, из мрамора Grafite. Зеркало Ekos V с подсветкой из светодиодов с четырех внутренних сторон, с лакированным алюминиевым профилем Quarzo. Полки Ljos из лакированного алюминия Quarzo в комплекте с аксессуарами и светодиодной подсветкой. Смесители Flow из сатинированной нержавеющей стали с традиционным картриджем.











TOUCH 19.02

Bianco Arabescato  
100 x 88 x 40 cm  
39 3/8" x 34 5/8" x 15 3/4"

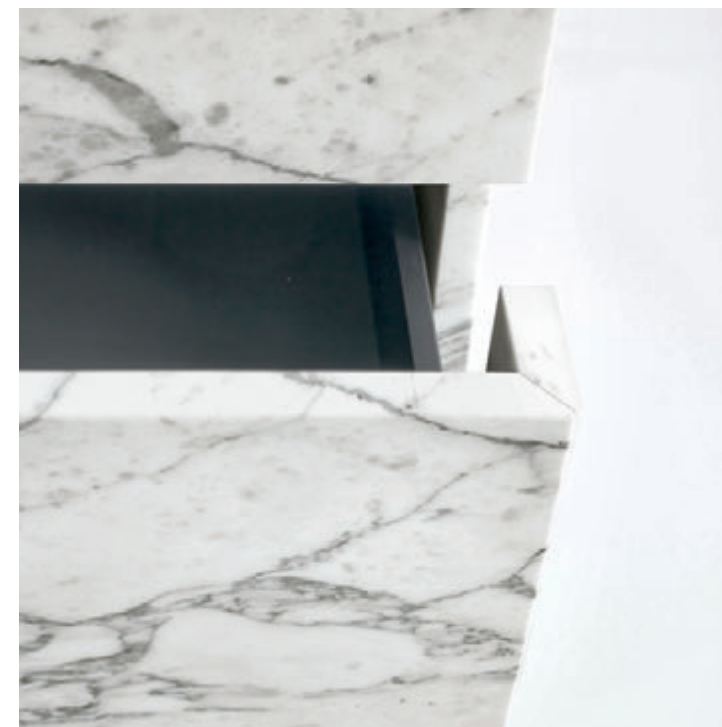

Base predisposta per scarico a pavimento con lavabo Short 100 in marmo Bianco Arabescato. Specchiera Vetra sp. 2,8 cm con retroilluminazione a LED quattro lati. Lampade Moon a LED. Rubinetteria Flow in acciaio inox satinato con cartuccia tradizionale. | Floor drain base unit with Short 100 Arabescato Bianco marble washbasin. Vetra mirror, th. 2.8 cm, with all-round LED backlight. Moon LED lamps. Flow taps in brushed stainless steel, with traditional cartridge. | Base prévue pour évacuation au sol avec lavabo Short 100 en marbre Bianco Arabescato. Miroir Vetra ép. 2,8 cm avec rétroéclairage à LED sur les quatre côtés. Lampes Moon à LED. Robinetterie Flow en acier inox satiné avec cartouche traditionnelle. Für Bodenablauf vorgerüsteter Unterbau mit Waschbecken Short 100 aus Arabescato-Marmor im Farbton Bianco. Spiegel Vetra, Dicke 2,8 cm, mit vierseitiger LED-Hintergrundbeleuchtung. LED-Leuchten Moon. Wasserhähne Flow aus satiniertem Edelstahl mit traditioneller Kartusche. Тумба со сливом в пол с раковиной Short 100 из мрамора Bianco Arabescato. Зеркало Vetra толщ. 2,8 см с подсветкой из светодиодов с четырех сторон. Светодиодные лампы Moon. Смесители Flow из satinированной нержавеющей стали с традиционным картриджем.



TOUCH 19.03

Rovere Barrique  
Milltek Solid  
64 x 88 x 40 cm  
25 1/4" x 34 5/8" x 15 3/4"

Base predisposta per scarico a pavimento in Rovere Barrique con lavabo Short 64 in Milltek Solid. Zoccolo in laccato Nero opaco. Rubinetteria H2O cromo. Specchiera Vetra sp. 2,8 cm con retroilluminazione a LED quattro lati.

Rovere Barrique floor drain base unit with Short 64 Milltek Solid washbasin. Matt Nero lacquered plinth. H2O chrome taps. Vetra mirror, th. 2.8 cm, with all-round LED backlight.

Base prévue pour vidage au sol en Rovere Barrique avec lavabo Short 64 en Milltek Solid. Socle laqué Nero mat. Robinetterie H2O chrome. Miroir Vetra ép. 2,8 cm avec rétroéclairage à LED sur les quatre côtés.

Für Bodenablauf vorgerüsteter Unterbau aus Rovere Barrique mit Waschbecken Short 64 aus Milltek Solid. Sockel mit Lackoberfläche in Nero Matt. Wasserhähne H2O Chrom. Spiegel Vetra, Dicke 2,8 cm, mit vierseitiger LED-Hintergrundbeleuchtung.

Тумба со сливом в пол из дуба отделкой Rovere Barrique с раковиной Short 64 из Milltek Solid. Цоколь в черном матовом лаке. Смесители H2O хромированные. Зеркало Vetra толщ. 2,8 см подсветкой из светодиодов с четырех сторон.











TOUCH 19.04

Argilla Arena  
 Milltek Solid  
 41 x 88 x 40 cm  
 16 1/8" x 34 5/8" x 15 3/4"



Basi predisposte per scarico a pavimento in argilla Arena con lavabo Full 41 in Milltek Solid. Zoccolo in laccato Nero opaco. Rubinetteria H2O cromo. Specchiere Vetra sp. 2,8 con retroilluminazione a LED due lati verticali. | Arena Argilla floor drain bases unit with Full 41 Milltek Solid washbasin. Matt Nero lacquered plinth. H2O chrome taps. Vetra mirror, th. 2,8 cm, with double-sided vertical LED backlight. | Bases prévues pour l'évacuation au sol en argile Arena avec lavabo Full 41 en Milltek Solid. Socle laqué Nero mat. Robinetterie H2O Chrom. Miroirs Vetra ép.2,8 cm avec rétroéclairage à LED sur les deux côtés verticaux. | Für Bodenablauf vorgerüstete Unterbauten Lehm im Farbton Arena mit Waschbecken Full 41 aus Milltek Solid. Sockel mit Lackoberfläche in Nero Matt. Wasserhähne H2O Chrom. Spiegel Vetra, Dicke 2,8 cm, mit LED-Hintergrundbeleuchtung auf den beiden vertikalen Seiten. | Тумба со сливом в пол из глины Arena с раковиной Full 41 из Milltek Solid. Цоколь в черном матовом лаке. Смесители H2O хромированные. Зеркала Vetra толщ. 2,8 с подсветкой из светодиодов с двух вертикальных сторон.





TOUCH 19.05

Bianco  
 Milltek Solid  
 100 x 88 x 48 cm  
 39 3/8" x 34 5/8" x 18 7/8"



Base con distanziale predisposta per scarico a parete in laccato Bianco opaco con lavabo Short 100 in Milltek Solid. Zoccolo in laccato Nero opaco. Rubinetteria H2O cromo. Specchiere contenitore ad incasso nella versione ad ante e specchio fisso con illuminazione a LED inferiore. | Base unit with matt Bianco lacquered wall drain spacer, with Short 100 Milltek Solid washbasin. Matt Nero lacquered plinth. H2O chrome taps. Recessed storage mirrors in the version with doors and fixed mirror with lower LED lighting. | Base à entretoise prévue pour l'évacuation murale laqué Bianco mat avec lavabo Short 100 en Milltek Solid. Socle laqué Nero mat. Robinetterie H2O chrome. Miroirs de rangement encastrés version à portes et miroir fixe éclairage à LED sur le bas. | Unterbau für Wandablauf vorgerüsteter Distanzplatte mit Oberfläche im Farbton Bianco Matt und Waschbecken Short 100 aus Milltek Solid. Sockel mit Lackoberfläche in Nero Matt. Wasserhähne H2O Chrom. Eingebaute Spiegel / Behältnisse mit Led-Beleuchtung in der Ausführung mit Türflügeln und festem Spiegel mit LED-Beleuchtung im unteren Bereich. | Тумба с распорной деталью со сливом в стену, отделка в белом матовом лаке, с раковиной Short 100 из Milltek Solid. Цоколь в черном матовом лаке. Смесители H2O хромированные. Встроенные зеркала-шкафчики, модель со створками и фиксированным зеркалом, с подсветкой нижним светодиодом.



# Sintesi Collection

design by Michele Marcon

Una proposta versatile e trasversale che consente un'ampia libertà compositiva grazie a elementi e accessori diversi, tutti contraddistinti da un rigore assoluto e dalla possibilità di scegliere tra tre tipologie di apertura: maniglia, oggi disponibile anche laccata, gola o push-pull. Dalle specchiere retroilluminate con mensole portaoggetti, ai lavabi integrati o da appoggio di diverse forme con bordi sottili, dai top ottenuti da materiali preziosi ai contenitori con layout diversi che contemplano la presenza anche di vani a giorno, tutti realizzati con materiali unici ed ecosostenibili.

A versatile and cross-purpose proposal allowing utmost freedom of composition, thanks to a wide range of elements and accessories, whose common denominator is uncompromising stylistic rigor, and that all feature the possibility of choosing among three types of door opening systems: handle, hand grip or push-pull. From the backlist mirrors with shelves, to integrated or stand-alone washbasin units in different shapes and with thin edges, from the surface tops in precious materials to containers with different layouts and a mix of closed or open-fronted units, all these are made with high quality, environmentally friendly materials.

Une proposition polyvalente et transversale permettant une grande liberté de composition grâce à des éléments et accessoires différents se distinguant tous par une rigueur absolue et par la possibilité de choisir entre trois types d'ouverture : poignée disponible également laquée, gorge ou push-pull. Des miroirs rétro-éclairés avec tablettes porte-objets aux lavabos - intégrés ou posés - à bords fins de différentes formes en passant par les plans réalisés en matières nobles et par les éléments de rangement modulables en plusieurs configurations et parfois dotés de niches ouvertes, tous les produits sont fabriqués avec des matériaux uniques et respectueux de l'environnement.

Eine vielseitige Lösung, die bei der Gestaltung dank unterschiedlich beschaffener Elemente und Zubehörteile, die sich alle durch ihren hohen Grad an Formstrenge auszeichnen, den größtmöglichen Spielraum lässt, auch in Bezug auf die Auswahl der Türöffnungssysteme: Türgriff, jetzt auch in der lackierten Version erhältlich, Aussparungen oder Touch-System. Von den hintergrundbeleuchteten Wandspiegeln mit Auflageflächen bis zu den eingebauten Waschbecken oder von den Auflagen unterschiedlichster Formen mit feinem Abschluss bis zu den aus wertvollen Materialien gefertigten Behältnissen, deren Erscheinungsbild auch dem Vorhandensein von türlosen Regalen Rechnung trägt, sind alle Objekte aus einzigartigen und nachhaltigen Werkstoffen gefertigt.

Гибкое решение, обеспечивающее большую свободу при создании интерьера, благодаря наличию различных элементов и аксессуаров, объединенных совершенством и строгостью форм, с несколькими вариантами открытия: за ручку, доступную также в лакированной версии, при помощи паза или при нажатии на створку. Подсвеченные зеркала с полочками для размещения предметов, встроенные или опирающиеся на столешницу раковины различной формы с тонкими краями, столешницы из драгоценных материалов, шкафчики с различным внутренним расположением, дополняемые также открытыми элементами - вся мебель выполнена из уникальных и экологически чистых материалов.



Ametista  
 Milltek Solid  
 Quarzo  
 182,4 (1,2+ 90 + 90 + 1,2) x 24 x 51 cm  
 71 3/4" (1/2" + 35 3/8" + 35 3/8" + 1/2") x 9 1/2" x 20 1/8"

Top sospeso integrato Still 04 in Milltek Solid. Basi con apertura push-pull, top e fianchi di finitura in laccato Ametista opaco. Specchiera Ekos V con retroilluminazione a LED quattro lati e profilo in alluminio laccato Quarzo. Portasciugamani Roma verniciato nero. Pensili contenitori in laccato Ametista opaco con illuminazione a LED inferiore. Sanitari Senna in ceramica opaca. Piatto doccia Line in Milltek solid. Rubinetteria Flow in acciaio inox finitura PVD nero opaco con cartuccia tradizionale per sanitari e lavabo, cartuccia progressiva per sistema doccia.

Still 04 Milltek Solid in-built wall-hung top. Matt Ametista finish lacquered push-pull opening base units, tops and sides. Ekos V mirror with all-round LED backlight and Quarzo finish lacquered aluminium profile. Roma black painted towel rack. Matt Ametista lacquered storage wall units with lower LED lighting. Senna matt ceramic sanitary ware. Line Milltek Solid shower tray. Flow stainless steel taps and faucets, matt black PVD finish, with traditional cartridge for sanitary ware and washbasin, progressive cartridge for shower system.

Plan suspendu intégré Still 04 en Milltek Solid. Bases avec ouverture à système pousser-tirer, plan et côtés de finition laqué Ametista mat. Miroir Ekos V avec rétroéclairage à LED quatre côtés et profil en aluminium laqué Quarzo. Porte-serviettes Roma vernis noir. Meubles hauts de rangement laqué Ametista mat avec éclairage à LED au bas. Sanitaires Senna en céramique mate. Bac de douche Line en Milltek solid. Robinetterie Flow en acier inox finition PVD noir mat avec cartouche traditionnelle pour sanitaires et lavabo, cartouche progressive pour système douche.

Integrierte hängende Platte Still 04 aus Milltek Solid. Unterbauten mit Push&Pull-Öffnung, Platte und Ausführungsseiten mit Lackoberfläche im Farbton Ametista Matt. Spiegel Ekos V mit vierseitiger LED-Hintergrundbeleuchtung, Profil aus Aluminium mit Lackoberfläche im Farbton Quarzo. Handtuchhalter Roma, schwarz lackiert. Hängeschränke mit Lackoberfläche im Farbton Ametista Matt und LED-Beleuchtung im unteren Bereich. Sanitäranlagen Senna aus matter Keramik. Duschteller Line aus Milltek Solid. Wasserhähne Flow aus Edelstahl, Oberflächenausführung mit mattschwarzer PVD-Beschichtung, mit traditioneller Kartusche für Sanitäranlagen und Waschbecken, progressive Kartusche für das Duschsystem.

Интегрированная подвесная столешница Still 04 из Milltek Solid. Тумбы с открытием створки при нажатии, столешницей и боковинами в матовом лаке Ametista. Зеркало Ekos V с подсветкой из светодиодов с четырех сторон, с лакированным алюминиевым профилем Quarzo. Полотенцедержатель Roma окрашенный черной краской. Навесные шкафы с отделкой матовым лаком Ametista с подсветкой нижним светодиодом. Сантехника Senna из матовой керамики. Поддон для душа Line из Milltek solid. Смесители Flow из нержавеющей стали с черной матовой отделкой PVD с традиционным картриджем для сантехники и раковины и прогрессивным картриджем для душа.

















SINTESI 19.02

Argilla Polvere

218,4 (1,2+108 + 108 +1,2) x 24 x 47 cm

86" (1/2" + 42 1/2" + 42 1/2" + 1/2") x 9 1/2" x 18 1/2"



Top sospeso integrato Land 02 in argilla Polvere. Basi con gola superiore, fianchi di finitura e top in argilla Polvere. Specchiera Vetra sp. 2,8 cm con retroilluminazione a LED quattro lati. Rubinetteria Flow in acciaio inox satinato con cartuccia tradizionale. | Land 02 Argilla Polvere wall-hung in-built top. Base units with upper groove, Argilla Polvere finish sides and top. Vetra mirror, th. 2.8 cm, with all-round LED backlight. Flow taps in brushed stainless steel, with traditional cartridge. | Plan suspendu intégré Land 02 en Argilla Polvere. Bases avec gorge supérieure, côtés de finition et plan en Argilla Polvere. Miroir Vetra ép. 2,8 cm avec rétroéclairage à LED sur les quatre côtés. Robinetterie Flow en acier inox satiné avec cartouches traditionnelles. | Integrierte hängende Platte Land 02 aus Lehm im Farbton Polvere. Unterbauten mit oberer Gehrung, Ausführungsseiten und Platte aus Lehm im Farbton Polvere. Spiegel Vetra, Dicke 2,8 cm, mit vierseitiger LED-Hintergrundbeleuchtung. Wasserhähne Flow aus satiniertem Edelstahl mit traditioneller Kartusche. | Интегрированная подвесная столешница Land 02 из Argilla Polvere. Тумбы с верхним пазом, боковины и столешница из глины Polvere. Зеркало Vetra толщ. 2,8 см с подсветкой из светодиодов с четырех сторон. Смесители Flow из satinированной нержавеющей стали с традиционным картриджем.



SINTESI 19.03

Bianco

Grafite

Milltek Solid

218,4 (1,2 + 72 + 72 + 72 + 1,2) x 36 - 24 x 51 cm

86" (1/2" + 28 3/8" + 28 3/8" + 28 3/8" + 1/2") x 14 1/8" - 9 1/2" x 20 1/8"



Top integrato d'appoggio sp. 10 Dip 58 in Milltek Solid. Basi con apertura push-pull in laccato Bianco opaco e in laccato Grafite opaco. Specchiera Vetra sp. 2,8 cm con retroilluminazione a LED quattro lati. Lampada Linus 72 a LED. Rubinetteria H2O cromo. | Dip 58 Milltek Solid in-built sit-on washbasin th. 10 cm. Matt Bianco and matt Grafite lacquered push-pull opening base units. Vetra mirror, th. 2.8 cm, with all-round LED backlight. Linus 72 LED lamp. H2O chrome taps. | Plan intégré à poser ép. 10 cm Dip 58 en Milltek Solid. Bases à ouverture système pousser-tirer en laqué Bianco mat et en laqué Grafite mat. Miroir Vetra ép. 2,8 cm avec rétroéclairage à LED sur les quatre côtés. Lampe Linus 72 à LED. Robinetterie H2O chrome. | Integrierte Auflageplatte, Dicke 10 cm Dip 58 aus Milltek Solid. Unterbauten mit Push&Pull Öffnungssystem mit Lackoberfläche im Farbton Bianco Matt und Grafite Matt. Spiegel Vetra, Dicke 2,8 cm, mit vierseitiger LED-Hintergrundbeleuchtung. LED-Leuchte Linus 72. Wasserhähne H2O cromo. | Интегрированная накладная столешница толщ. 10 Dip 58 из Milltek Solid. Тумбы с открытием при нажатии с отделкой в белом матовом лаке и в матовом лаке Grafite. Зеркало Vetra толщ. 2,8 см с подсветкой из светодиодов с четырех сторон. Светодиодная лампа Linus 72. Смесители H2O хромированные.



Argilla Polvere  
 Cristalplant  
 216 (108 + 108) x 24 x 38,8 cm | top 189 x 6 x 51 cm  
 85" (42 1/2" + 42 1/2") x 9 1/2" x 15 1/4" | top 74 3/8" x 2 3/8" x 20 1/8"

Lavabo in appoggio Step 45.21 in Cristalplant con finitura esterna in argilla Polvere. Top sospeso, alzatina con illuminazione a LED superiore, basi con apertura push-pull e top in argilla Polvere. Specchiera Vetra sp. 2,8 cm. Sanitari Senna in ceramica lucida. Rubinetteria Flow in acciaio inox satinato con cartuccia tradizionale.

Step 45.21 Cristalplant sit-on washbasin with Argilla Polvere outer finish. Wall-hung top, back-splash with upper LED lighting, Polvere clay top and push-pull opening base units. Vetra mirror, th. 2.8 cm. Senna glossy ceramic sanitary ware, Flow taps in brushed stainless steel, with traditional cartridge.

Lavabo à poser Step 45.21 en Cristalplant avec finition externe en argile Polvere. Plan suspendu, dossier avec éclairage à LED supérieur, bases avec ouverture système pousser-tirer et plan en argilla Polvere. Miroir Vetra ép. 2,8 cm. Sanitaires Senna en céramique brillante Robinetterie Flow en acier inox satiné avec cartouche traditionnelle.

Auflagewaschbecken Step 45.21 aus Cristalplant mit äußerer Oberflächenausführung aus Lehm im Farbton Polvere. Hängende Platte, Aufbau mit LED-Beleuchtung im oberen Bereich, Unterbauten mit Push&Pull Öffnungssystem und Platte in der Farbe Argilla Polvere. Spiegel Vetra Dicke 2,8 cm. Sanitäranlagen Senna aus glänzender Keramik Wasserhähne Flow aus satiniertem Edelstahl mit traditioneller Kartusche.

Накладная раковина Step 45.21 из Cristalplant с наружной отделкой из глины Polvere. Подвесная столешница, задняя стенка с подсветкой верхним светодиодом, тумбы с открытием при нажатии и столешница из глины Polvere. Зеркало Vetra толщ. 2,8 см. Сантехника Senna из глянцевой керамики, смесители Flow из satinированной нержавеющей стали с традиционным картриджем.



















SINTESI 19.05

Zaffiro

Ceramilux matt

Cristalplant

200,4 (1,2 + 126 + 72 + 1,2) x 24 x 47 cm

78 7/8" (1/2" + 49 5/8" + 28 3/8" + 1/2") x 9 1/2" x 18 1/2"



Lavabi in appoggio Bowl 40 in Ceramilux matt. Top sospeso in Cristalplant. Basi con gola superiore, top e fianchi di finitura in laccato Zaffiro opaco. Specchiere Vetra sp. 2,8 cm. Lampade Linus mtl a LED. Rubinetteria Flow in acciaio inox satinato con cartuccia tradizionale. | Bowl 40 Ceramilux matt sit-on washbasins. Cristalplant wall-hung top. Base units with upper groove, matt Zaffiro finish lacquered top and sides. Vetra mirror, th. 2.8 cm Linus Mtl LED lamps. Flow taps in brushed stainless steel, with traditional cartridge. | Lavabos à poser Bowl 40 en Ceramilux mat. Plan suspendu en Cristalplant. Bases avec gorge supérieure, plan et côtés de finition laqué Zaffiro mat. Miroirs Vetra ép. 2,8 cm. Lampes Linus Mtl à LED. Robinetterie Flow en acier inox satiné avec cartouche traditionnelle. | Auflegewaschbecken Bowl 40 aus Ceramilux Matt. Hängende Platte aus Cristalplant. Unterbauten mit oberer Gehrung, Platte und Ausführungsseiten mit Lackoberfläche im Farbton Zaffiro Matt. Spiegel Vetra Dicke 2,8 cm. Led-Leuchte Linus Mtl. Wasserhähne Flow aus satiniertem Edelstahl mit traditioneller Kartusche. Накладные раковины Bowl 40 из Ceramilux matt. Подвесная столешница из Cristalplant. Тумбы с верхним пазом, столешница и боковины в матовом лаке Zaffiro. Зеркала Vetra толщ. 2,8 см. Светодиодные лампы Linus Mtl. Смесители Flow из satinированной нержавеющей стали с традиционным картриджем.





SINTESI 19.06

Rovere Barrique

Origano

ceramica | ceramic

182,4 (1,2 + 90 + 90 + 1,2) x 36 x 47 cm | top 225 x 8 x 47 cm

71 3/4" (1/2" + 35 3/8" + 35 3/8" + 1/2") x 14 1/8" x 18 1/2" | top 88 5/8" x 3 1/8" x 18 1/2"



Lavabo in appoggio Den R50 in ceramica bianca lucida. Top sospeso in Rovere Barrique. Basi con apertura push-pull e fianchi di finitura in laccato Origano opaco. Specchiera Klose con anta girevole in laccato Origano opaco e con specchio ingranditore. Lampade Flat a LED. Rubinetteria Flow in acciaio inox satinato con cartuccia tradizionale. | Den R50 glossy white ceramic sit-on washbasin. Wall-hung Rovere Barrique top. Matt Origano finish lacquered push-pull opening base units and sides. Klose mirror with matt Origano finish lacquered revolving door and with magnifying mirror. Flat LED lamps. Flow taps in brushed stainless steel, with traditional cartridge. | Lavabo à poser Den R50 en céramique blanche brillante. Plan suspendu en Rovere im Farbton Barrique. Bases avec ouverture à système pousser-tirer et côtés de finition laqué Origano mat. Miroir Klose avec porte pivotante laqué Origano mat et miroir grossissant. Lampes à LED Flat. Robinetterie Flow en acier inox satiné avec cartouche traditionnelle. Aufgawaschbecken Den R50 aus weiß glänzender Keramik. Hängende Platte aus Rovere Barrique. Unterbauten mit Push&Pull-Öffnung und Ausführungsseiten mit Lackoberfläche im Farbton Origano Matt. Spiegel Klose mit drehbarer Tür und Lackoberfläche in Origano Matt sowie Vergrößerungsspiegel. Led-Leuchte Flat. Wasserhähne Flow aus satiniertem Edelstahl mit traditioneller Kartusche. | Накладная раковина Den R50 из глянцевой белой керамики Bianca. Подвесная столешница из дуба Barrique. Тумбы с открытием створки при нажатии и боковинами в матовом лаке Origano. Зеркало Klose с поворотной створкой в матовом лаке Origano, с увеличительным зеркалом. Светодиодные лампы Flat. Смесители Flow из satinированной нержавеющей стали с традиционным картриджем.



Castoro  
 Rovere Carbone  
 Cristalplant  
 218,4 (1,2 + 90 + 36 + 90 + 1,2) x 36 x 51 cm  
 86 (1/2" + 35 3/8" + 14 1/8" + 35 3/8" + 1/2") x 14 1/8" x 20 1/8"

Lavabi in appoggio Bowl 45 in Cristalplant. Basi con apertura push-pull, top e fianchi di finitura in laccato Castoro opaco con vano a giorno in Rovere Carbone. Specchiere Vetra sp. 2,8 cm con retroilluminazione a LED quattro lati. Colonne con struttura e vano a giorno in Rovere Carbone, ante in laccato Castoro opaco. Consolle serie Bali. Portasciugamani Darma nero. Rubinetteria Flow in acciaio inox satinato con cartuccia tradizionale.

Bowl 45 Cristalplant sit-on washbasins. Base units with push-pull opening, matt Castoro finish top and sides with Rovere Carbone open shelving. Vetra mirror, th. 2.8 cm, with all-round LED backlight. Columns with Rovere Carbone frame and open shelving, matt Castoro finish lacquered doors. Bali series console. Darma black towel rack. Flow taps in brushed stainless steel, with traditional cartridge.

Lavabos à poser Bowl 45 en Cristalplant. Bases avec ouverture système pousser-tirer, plan et côtés de finition laqué Castoro mat avec élément à jour en Rovere Carbone. Miroirs Vetra ép. 2.8 cm avec rétroéclairage à LED sur les quatre côtés. Colonnes avec structure et élément à jour en Rovere Carbone, portes en laqué Castoro mat. Étagère série Bali. Porte-serviettes Darma noir. Robinetterie Flow en acier inox satiné avec cartouche traditionnelle.

Auflagewaschbecken Bowl 45 aus Cristalplant. Unterbauten mit Push&Pull-Öffnung, Platte und Ausführungsseiten mit Lackoberfläche im Farbton Castoro Matt und offenes Fach aus Rovere im Farbton Carbone. Spiegel Vetra, Dicke 2,8 cm, mit vierseitiger LED-Hintergrundbeleuchtung. Säulen mit Struktur und offenes Fach aus Rovere im Farbton Carbone, Türen mit Lackoberfläche in der Farbe Castoro Matt. Konsole Serie Bali. Handtuchhalter Darma, schwarz. Wasserhähne Flow aus satinierem Edelstahl mit traditioneller Kartusche.

Накладные раковины Bowl 45 из Cristalplant. Тумбы с открытием створки при нажатии, столешница и боковины в матовом лаке Castoro, с открытым элементом из дуба Rovere Carbone. Зеркала Vetra толщ. 2,8 см с подсветкой из светодиодов с четырех сторон. Шкаф-пеналы с конструкцией и открытым элементом из дуба Rovere Carbone, створки с в матовом лаке Castoro. Консоль серии Bali. Полотенцедержатель Darma черного цвета. Смесители Flow из сатинированной нержавеющей стали с традиционным картриджем.























SINTESI 19.08

Pietra

Cristalplant

218,4 (1,2 + 36 + 90 + 90 + 1,2) x 48 x 51 cm

86" (1/2" + 14 1/8" + 35 3/8" + 35 3/8" + 1/2") x 18 7/8" x 20 1/8"



Lavabi in appoggio Loop in Cristalplant. Basi con gola centrale, top e fianchi di finitura in laccato Pietra opaco. Specchiera Vetra sp. 2,8 cm. Lampada Linus mtl a LED. Rubinetteria Flow in acciaio inox lucido con cartuccia tradizionale. | Loop Cristalplant sit-on washbasins. Base units with central groove, matt Pietra finish lacquered top and sides. Vetra mirror, th. 2.8 cm. Linus mtl LED lamp. Flow taps and faucets made of polished stainless steel, with traditional cartridge. | Lavabos à poser Loop en Cristalplant. Bases avec gorge centrale, plan et côtés de finition en laqué Pierre mat. Miroir Vetra ép. 2,8 cm. Lampe Linus mtl à LED. Robinetterie Flow en acier inox brillant avec cartouche traditionnelle. | Auflegewaschbecken Loop aus Cristalplant. Unterbauten mit lotrecht Gehrung, Platte und Ausführungsseiten mit Lackoberfläche im Farbton Pietra Matt. Spiegel Vetra, Dicke 2,8. Led-Leuchte Linus mtl. Wasserhähne Flow aus glänzendem Edelstahl mit traditioneller Kartusche. | Накладные раковины Loop из Cristalplant. Тумбы с центральным пазом, столешница и боковины в матовом лаке цвета "камень" (Pietra). Зеркало Vetra толщ. 2,8 см. Светодиодная лампа Linus mtl. Смесители Flow из блестящей нержавеющей стали с традиционным картриджем.





SINTESI 19.09

Fango, vetro extrachiario | back-painted glass

Rovere Miele

164,4 (1,2 + 54 + 108 + 1,2) x 36 x 51 cm – 218,4 (1,2 + 108 + 108 + 1,2) x 24 x 47 cm

64 3/4" (1/2" + 21 1/4" + 42 1/2" + 1/2") x 14 1/8" x 20 1/8" – 86" (1/2" + 42 1/2" + 42 1/2" + 1/2") x 9 1/2" x 18 1/2"



Top integrato Brilliant 04 in vetro extrachiario retroverniciato Fango. Basi con gola superiore e fianchi di finitura in laccato Fango lucido e in Rovere Miele. Colonna in Rovere Miele. Specchiera Vetra sp. 2,8 cm. Lampade Regolo LED. Rubinetteria Flow in acciaio inox lucido con cartuccia tradizionale. | Brilliant 04 extra-clear, Fango back-painted glass in-built top. Base units with upper groove, and glossy Fango finish lacquered and Rovere Miele sides. Rovere Miele column. Vetra mirror, th. 2.8 cm. Regolo LED lamps. Flow taps in polished stainless steel, with traditional cartridge. | Plan intégré Brilliant 04 en verre extra-clair rétro-peint Fango. Bases avec gorge supérieure et côtés de finition en laqué Fango brillant et en Rovere Miele. Colonne en Rovere Miele. Miroir Vetra ép.2,8 cm. Lampes LED Regolo. Robinetterie Flow en acier inox brillant avec cartouche traditionnelle. | Integrierte Platte Brilliant 04 aus extrahellem Glas und im Farbton Fango hintergrundlackiert. Unterbauten mit oberer Gehrung und Ausführungsseiten mit Lackoberfläche im Farbton Fango glänzend und Rovere Miele. Säule aus Rovere im Farbton Miele. Spiegel Vetra Dicke 2,8 cm. LED-Beleuchtung Regolo. Wasserhähne Flow aus glänzendem Edelstahl mit traditioneller Kartusche. | Интегрированная столешница Brilliant 04 из сверхсветлого стекла с окраской Corda. Тумбы с верхним пазом и боковинами в глянцевом лаке Fango и Rovere Miele. Шкаф-пенал из Rovere Miele. Зеркало Vetra толщ.2,8 см. Светодиодные лампы Regolo. Смесители Flow из блестящей нержавеющей стали с традиционным картриджем.



## SINTESI 19.10

Rovere Tundra

Corian

272,4 (1,2 + 90 + 90 + 90 + 1,2) x 48 x 51 cm

107 1/4" (1/2" + 35 3/8" + 35 3/8" + 35 3/8" + 1/2") x 18 7/8" x 20 1/8"

Top integrato Span 04 in Corian. Basi con gola centrale e fianchi di finitura in Rovere Tundra. Specchiera Vetra sp. 2,8 cm con retroilluminazione a LED due lati superiore e inferiore. Pensile a specchio. Piatto doccia Sharp in Ceramilux matt. Sanitari Senna in ceramica opaca. Rubinetteria Flow in acciaio inox satinato con cartuccia tradizionale.

Span 04 Corian in-built top. Base units with central groove and Rovere Tundra finish sides. Vetra mirror, th. 2.8 cm, with double-sided upper and lower LED backlight. Mirrored wall unit. Sharp Ceramilux matt shower tray. Senna matt ceramic sanitary ware. Flow taps in brushed stainless steel, with traditional cartridge.

Plan intégré Span 04 en Corian. Bases avec gorge centrale et côtés de finition en Rovere Tundra. Miroir Vetra ép.2,8 cm avec rétroéclairage à LED sur les deux côtés haut et bas. Meuble haut avec miroir. Bac de douche Sharp en Ceramilux mat. Sanitaires Senna en céramique mate. Robinetterie Flow en acier inox satiné avec cartouche traditionnelle.

Integrierte Platte Span 04 aus Corian. Unterbauten mit lotrechter Gehrung und Ausführungsseiten aus Rovere im Farbton Tundra. Spiegel Vetra, Dicke 2,8 cm, mit LED-Hintergrundbeleuchtung oben und unten auf den beiden Seiten. Hängespiegelschrank. Duschteller Sharp aus Ceramilux Matt. Sanitäranlagen Senna aus matter Keramik. Wasserhähne Flow aus satiniertem Edelstahl mit traditioneller Kartusche.

Интегрированная столешница Span 04 из Corian. Тумбы с центральным пазом и боковинами из дуба Rovere Tundra. Зеркало Vetra толщ. 2,8 см с подсветкой из светодиодов с двух сторон, верхней и нижней. Зеркальный навесной шкафчик. Поддон для душа Sharp из Ceramilux matt. Сантехника Senna из матовой керамики. Смесители Flow из сатинированной нержавеющей стали с традиционным картриджем.



















SINTESI 19.11

Neve, vetro acidato | etched glass  
 182,4 (1,2 + 54 + 90 + 36 + 1,2) x 36 x 47 cm  
 71 3/4" (1/2" + 21 1/4" + 35 3/8" + 14 1/8" + 1/2") x 14 1/8" x 18 1/2"



Top integrato Brilliant 04 in vetro acidato Neve. Basi con maniglia trafila M051 in laccato Neve opaco. Specchiera Linea H sp. 2,8 cm con due fasce acidate verticali e retroilluminazione a LED quattro lati. Rubinetteria Flow in acciaio inox satinato con cartuccia tradizionale. | Brilliant 04 Neve etched glass in-built top. Matt Neve lacquered base units with M051 handles. Linea H mirror, th. 2.8 cm, with two vertical etched glass effect strips and all-round LED backlight. Flow taps in brushed stainless steel, with traditional cartridge. | Plan intégré Brilliant 04 en verre dépoli à l'acide Neve. Bases avec poignée tréfilage M051 en laqué Neve mat. Miroir Linea H ép. 2,8 cm avec deux bandes dépolies à l'acide verticales et rétroéclairage à LED sur les quatre côtés. Robinetterie Flow en acier inox satiné avec cartouche traditionnelle. | Integrierte Platte Brilliant 04 aus geätztem Glas in der Farbe Neve. Unterbauten mit Griff Trafila M051 und Lackoberfläche im Farbton Neve Matt. Spiegel Linea H, Dicke 2,8 cm, mit zwei vertikalen geätzten Streifen und auf beiden Seiten mit LED-Hintergrundbeleuchtung. Wasserhähne Flow aus satiniertem Edelstahl mit traditioneller Kartusche. | Интегрированная столешница Brilliant 04 из травленого стекла Neve. Тумбы с рейлинговой ручкой M051 в матовом лаке Neve. Зеркало Linea H толщ. 2,8 см с двумя вертикальными травлеными полосами и подсветкой из светодиодов с четырех сторон. Смесители Flow из satinированной нержавеющей стали с традиционным картриджем.





SINTESI 19.12

Nero

Milltek Solid, nero | black

182,4 (1,2 + 72 + 72 + 36 + 1,2) x 81 x 38,8 cm

71 3/4" (1/2" + 28 3/8" + 28 3/8" + 14 1/8" + 1/2") x 31 7/8" x 15 1/4"



Top integrato Stage 01 in Milltek Solid nero. Basi con apertura push-pull in laccato Nero opaco. Zoccolo laccato Nero opaco. Specchiera Air con retroilluminazione a LED. Rubinetteria Flow in acciaio inox satinato con cartuccia tradizionale. | Stage 01 Milltek Solid black in-built top. Matt Nero lacquered base units with push-pull opening. Matt Nero lacquered plinth. Air mirror with LED backlight. Flow taps in brushed stainless steel, with traditional cartridge. | Plan intégré Stage 01 en Milltek Solid noir. Bases avec ouverture système pousser-tirer en laqué Nero mat. Socle laqué Nero mat. Miroir Air avec rétroéclairage à LED. Robinetterie Flow en acier inox satiné avec cartouche traditionnelle. | Integrierte Platte Stage 01 aus schwarzem Milltek Solid. Unterbauten mit Push&Pull-Öffnung und Lackoberfläche in Nero Matt. Sockel mit Lackoberfläche im Farbton Nero Matt. Spiegel Air mit LED-Hintergrundbeleuchtung. Wasserhähne Flow aus satiniertem Edelstahl mit traditioneller Kartusche. | Интегрированная столешница Stage 01 из черного Milltek Solid. Тумбы с открытием при нажатии в черном матовом лаке. Цоколь в черном матовом лаке. Зеркало Air со светодиодной подсветкой. Смесители Flow из satinированной нержавеющей стали с традиционным картриджем.





SINTESI 19.13

Venato Fumo

Milltek Solid

182,4 (1,2 + 36 + 36 + 108 + 1,2) x 48 x 38,8 cm

71 3/4" (1/2" + 14 1/8" + 14 1/8" + 42 1/2" + 1/2") x 18 7/8" x 15 1/4"



Lavabo semi-incasso Prop 49 in Milltek Solid. Basi in nobilitato Venato Fumo con maniglia M051 laccata Nero opaco. Specchiere contenitore semi-incasso con fianchi a specchio. Rubinetteria Flow in acciaio inox satinato con cartuccia tradizionale. | Prop 49 Milltek Solid semi-recessed washbasin. Venato Fumo faced-panels base units with M051 matt Nero lacquered handles. Semi-recessed storage mirror units with mirrored sides. Flow taps in brushed stainless steel, with traditional cartridge. | Lavabo semi-encasté Prop 49 en Milltek Solid. Bases en mélamine Venato Fumo avec poignée M051 laquée Nero mat. Miroirs de rangement semi-encastés avec côtés à miroir. Robinetterie Flow en acier inox satiné avec cartouche traditionnelle. | Halb eingebautes Waschbecken Prop 49 aus Milltek Solid. Unterbauten aus Melaminbeschichtete Spanplatten der Farbe Venato Fumo, mit Griff M051, Lackoberfläche im Farbton Nero Matt. Halb eingebaute Spiegelschränke mit Spiegelseiten. Wasserhähne Flow aus satiniertem Edelstahl mit traditioneller Kartusche. | Полувстраиваемая раковина Prop 49 из Milltek Solid. Тумбы из меламин Venato Fumo с ручкой M051 с отделкой черным матовым лаком. Полувстраиваемые зеркала-шкафчики с зеркальными боковинами. Смесители Flow из сатирированной нержавеющей стали с традиционным картриджем.



# One Collection

design by CR Noorth

Una nuova collezione di composizioni definite, la sintesi perfetta tra versatilità, semplicità d'uso ed essenzialità formale. Una linea che raggiunge la massima semplicità attraverso un linguaggio contemporaneo, per una proposta dedicata a spazi funzionali ed accoglienti, la cui identità è definita e valorizzata dalla purezza dei volumi e dalla ricercatezza stilistica. Un design curato nei dettagli ma soprattutto un progetto la cui sintesi è espressione di un prodotto assolutamente trasversale.

A new collection of well-defined compositions, the perfect synthesis of versatility, simplicity of use and essential design. A line that achieves maximum simplicity through a modern design for a range dedicated to functional and welcoming spaces whose identity is defined and enhanced by the purity of volumes and stylistic sophistication. A design focused on detail, but essentially a project whose synthesis is an expression of a purely transversal product.

Une nouvelle collection de compositions définies, la synthèse parfaite entre polyvalence, simplicité d'utilisation et essentialité des formes. Une ligne qui, grâce à son langage contemporain, atteint le maximum de la simplicité, pour une proposition dédiée à des espaces fonctionnels et accueillants, dont l'identité est définie et sublimée par la pureté des volumes et la recherche stylistique. Un design soigné dans les moindres détails mais surtout un projet dont la synthèse est l'expression d'un produit absolument transversal.

Eine neue Kollektion mit klar strukturierten Kompositionen, die perfekte Synthese aus Vielseitigkeit, unkomplizierter Handhabung und essentieller Formen. Eine Linie, die durch eine zeitgenössische Formgebung maximale Einfachheit erreicht und funktionellen und einladenden Räumen gewidmet ist, deren Identität durch die Reinheit der Volumen und stilistische Raffinesse geprägt ist und unterstrichen wird. Ein Design mit viel Liebe zum Detail, vor allem aber ein Projekt, dessen Synthese Ausdruck eines absolut transversalen Produkts ist.

Новая коллекция из определенных композиций, идеальное сочетание универсальности, простоты использования и формального минимализма. Эта линия достигла максимальной простоты благодаря современному способу самовыражения и представляет собой решение, предназначенное для функционального и уютного интерьера с определенной индивидуальностью, подчеркиваемой простотой форм и стилистической изысканностью. Тщательно продуманный дизайн и, прежде всего, проект, синтезом которого является продукция, предлагающая многогранность решений.



ONE 19.01

Venato Vaniglia  
Milltek Solid Light  
108 (72 + 36) x 36 x 51 cm  
42 1/2" (28 3/8" + 14 1/8") x 14 1/8" x 20 1/8"

Top integrato Layer 02 in Milltek Solid Light. Basi in nobilitato Venato Vaniglia con maniglia M800 laccata Bianco opaco. Portasciugamano da terra serie Toro in Rovere Carbone. Specchiera Air. Rubinetteria Flow in acciaio inox satinato con cartuccia tradizionale.

Layer 02 Milltek Solid Light in-built top. Venato Vaniglia faced panels base units with M800 matt Bianco lacquered handles. Toro Rovere Carbone floor-mounted towel rack. Air mirror. Flow taps in brushed stainless steel, with traditional cartridge.

Plan intégré Layer 02 en Milltek Solid Light. Bases en mélamine Venato Vaniglia avec poignée M800 laquée Bianco mat. Porte-serviette sur pied série Toro en Rovere Carbone. Miroir Air. Robinetterie Flow en acier inox satiné avec cartouche traditionnelle.

Integrierte Platte Layer 02 aus Milltek Solid Light. Unterbauten aus Melaminbeschichtete Spanplatten in der Farbe Venato Vaniglia mit Griff M800, Lackoberfläche in der Farbe Bianco Matt. Handtuchständer aus der Serie Toro aus Rovere im Farbton Carbone. Spiegel Air. Wasserhähne Flow aus satiniertem Edelstahl mit traditioneller Kartusche.

Интегрированная столешница Layer 02 из Milltek Solid Light. Тумбы из меламин Venato Vaniglia с ручкой M800 с отделкой белым матовым лаком. Напольный полотенцедержатель серии Toro из дуба Rovere Carbone. Зеркало Air. Смесители Flow из сатинированной нержавеющей стали с традиционным картриджем.















ONE 19.02

Pietra

Ceramilux matt

162 (90 + 72) x 48 x 51 cm

63 3/4" (35 3/8" + 28 3/8") x 18 7/8" x 20 1/8"



Lavabo sopra piano Basic R58 in Ceramilux matt. Basi con maniglia M800 cromo e vano a giorno in laccato Pietra opaco. Specchiera Vetra sp. 2,8 cm. Lampada Linus 45 a LED. Portasciugamano finitura cromo. Rubinetteria Flow in acciaio inox satinato con cartuccia tradizionale. | Basic R58 Ceramilux matt countertop washbasin. Base units with M800 chrome handle and matt Pietra finish lacquered open shelving. Vetra mirror, th. 2.8 cm Linus 45 LED lamp. Chrome-plated towel rack. Flow taps in brushed stainless steel, with traditional cartridge. | Lavabo sur plan Basic R58 en Ceramilux mat. Bases avec poignée M800 cromo et élément à jour laqué Pierre mat. Miroir Vetra ép. 2,8 cm. Lampe Linus 45 à LED. Porte-serviette finition cromo. Robinetterie Flow en acier inox satiné avec cartouche traditionnelle. | Aufliegendes Waschbecken Basic R58 aus Ceramilux Matt. Unterbauten mit Griff M800 Chrom und offenem Fach mit Lackoberfläche im Farbton Pietra Matt. Spiegel Vetra Dicke 2,8 cm. LED-Leuchte Linus 45. Handtuchhalter mit Oberflächenausführung Chrom. Wasserhähne Flow aus satiniertem Edelstahl mit traditioneller Kartusche. | Паковина, установленная поверх столешницы, Basic R58 из Ceramilux matt. Тумбы с хромированной ручкой M800 и открытым элементом в матовом лаке Pietra. Зеркало Vetra толщ. 2,8 см. Светодиодная лампа Linus 45. Напольный полотенцедержатель хромированный. Смесители Flow из сатинированной нержавеющей стали с традиционным картриджем.





ONE 19.03

Ares Argilla

Milltek Solid Light

144 (9 + 90 + 45) x 48 x 51 cm

56 3/4" (3 1/2" + 35 3/8" + 17 3/4") x 18 7/8" x 20 1/8"



Top integrato Layer 02 in laminato Ares Argilla e lavabi in Milltek Solid Light. Base con maniglia M801 cromo, base con vano portasciugamano, pensile con struttura e vano a giorno in nobilitato Ares Argilla. Specchiera Vetra sp. 2,8 cm. Lampada Kasio a LED. Rubinetteria Flow in acciaio inox satinato con cartuccia tradizionale. | Layer 02 Ares Argilla laminated in-built top and Milltek Solid Light washbasins. Base unit with M801 chrome handle, base unit with open shelving for towel storage and wall unit frame and open shelving in Ares Argilla faced-panels. Vetra mirror, th. 2.8 cm Kasio LED light. Flow taps in brushed stainless steel, with traditional cartridge. | Plan intégré Layer 02 en laminé Ares Argilla et lavabos en Milltek Solid Light. Base avec poignée M801 cromo, base avec élément porte-serviette, meuble haut avec structure et élément à jour en mélamine Ares Argilla. Miroir Vetra ép. 2,8 cm. Lampe Kasio à LED. Robinetterie Flow en acier inox satiné avec cartouche traditionnelle. | Integrierte Platte Layer 02 aus Ares-Laminat im Farbton Argilla und Waschbecken aus Milltek Solid Light. Unterbau mit Griff M801 Chrom, Unterbau mit Handtuchfach, Hängeschrank mit Struktur und offenem Fach aus Ares-Melaminbeschichtete Spanplatten in der Farbe Argilla. Spiegel Vetra Dicke 2,8 cm. LED-Leuchte Kasio. Wasserhähne Flow aus satiniertem Edelstahl mit traditioneller Kartusche. | Интегрированная столешница Layer 02 из ламината Ares Argilla и раковины из Milltek Solid Light. Тумба с хромированной ручкой M801, тумба с отсеком для полотенец, навесной шкафчик с конструкцией и открытым элементом из меламина Ares Argilla. Зеркало Vetra толщ. 2,8 см. Светодиодная лампа Kasio. Смесители Flow из satinированной нержавеющей стали с традиционным картриджем.

# Elements

2



Washbasins	284
Top	330
Bathtubs and shower trays	358
Taps	372
Sanitaryware	384
Mirrors and lamps	386
Inner equipment	398

# Elements



KID 60

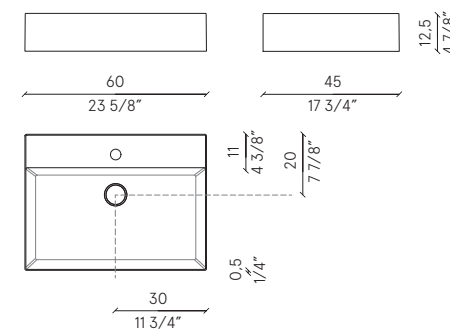

disposizione | layout | disposition | Anordnung | расположение

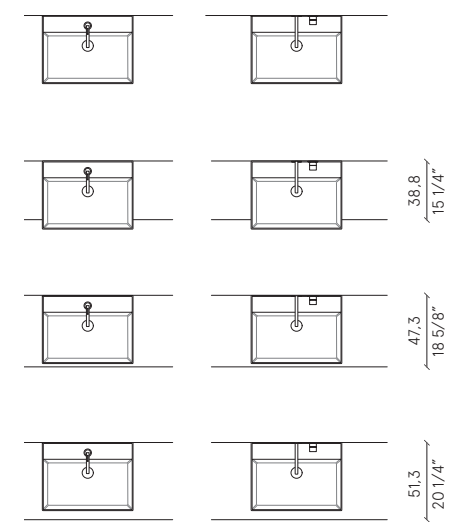

finiture | finishes | finitions | Oberflächen | отделки  
 ceramica lucida | glossy ceramic | céramique brillante | glänzende Keramik | глянецовая керамика

bianco





design Michele Marcon

MAN 63

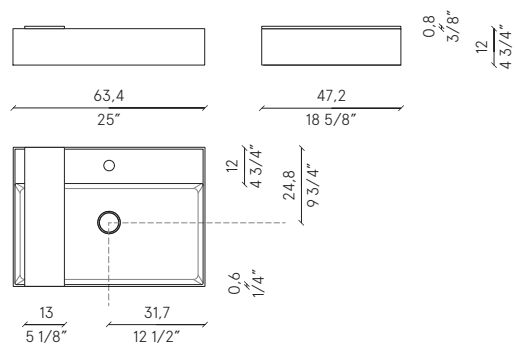

disposizione | layout | disposition | Anordnung | расположение

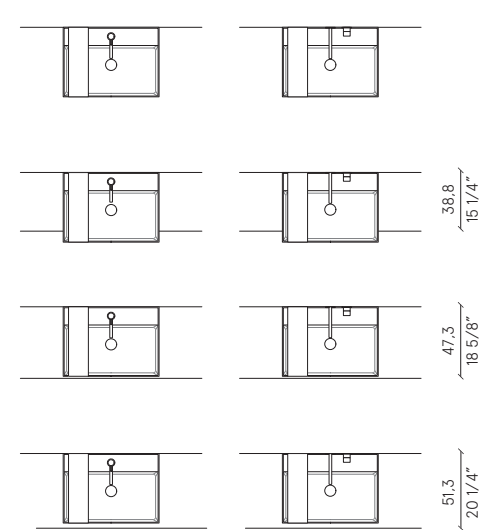

finiture | finishes | finitions | Oberflächen | отделки  
 sintetico opaco | matt synthetic | synthétique mat | Matt Synthetisch | матовое соединение

cristalplant



design Michele Marcon

MAN 90

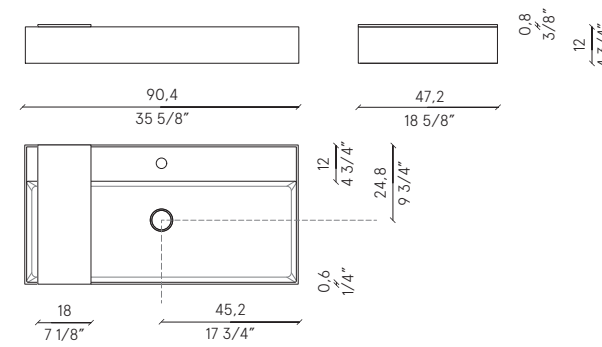

disposizione | layout | disposition | Anordnung | расположение

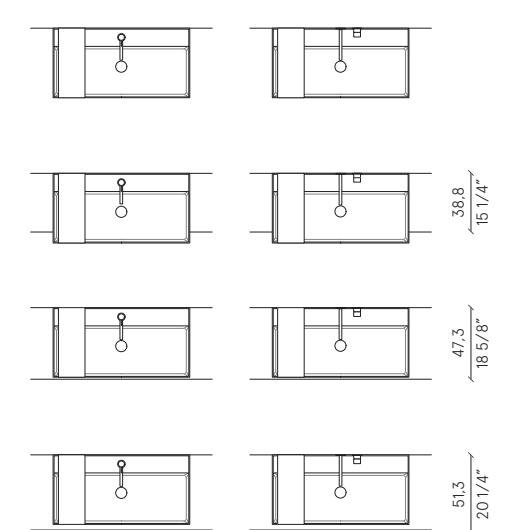

finiture | finishes | finitions | Oberflächen | отделки  
 sintetico opaco | matt synthetic | synthétique mat | Matt Synthetisch | матовое соединение

cristalplant



design Michele Marcon

MAN 108 S

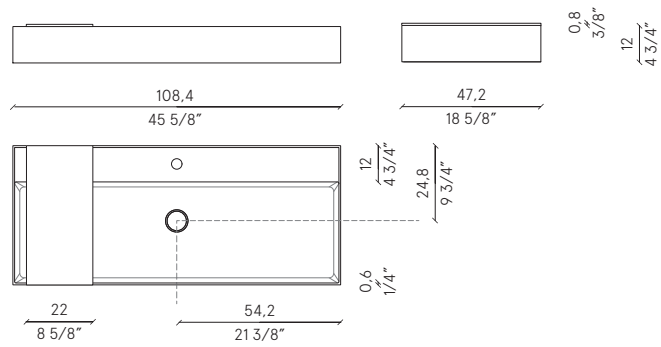

disposizione | layout | disposition | Anordnung | расположение

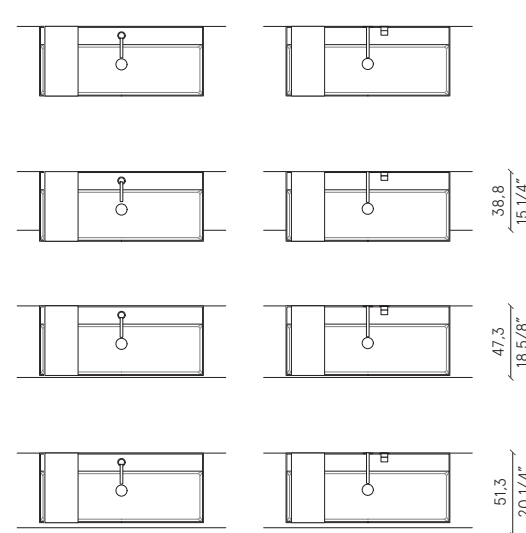

finiture | finishes | finitions | Oberflächen | отделки  
 sintetico opaco | matt synthetic | synthétique mat | Matt Synthetisch | матовое соединение

cristalplant



design Michele Marcon

MAN 108 D

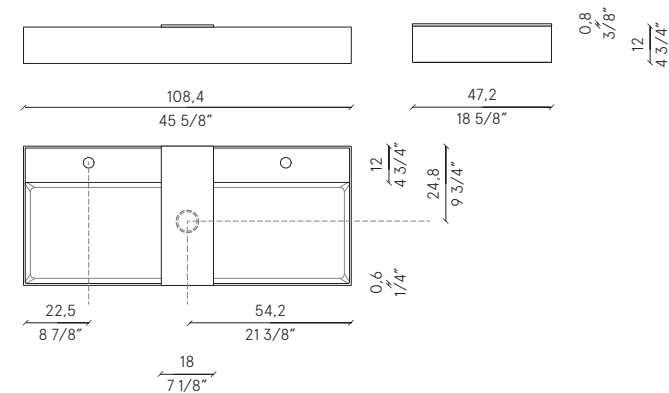

disposizione | layout | disposition | Anordnung | расположение

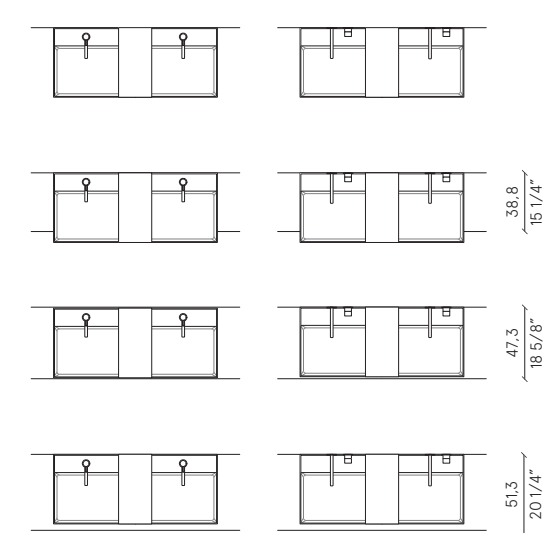

finiture | finishes | finitions | Oberflächen | отделки  
 sintetico opaco | matt synthetic | synthétique mat | Matt Synthetisch | матовое соединение

cristalplant





design Michele Marcon

MAN 126 S

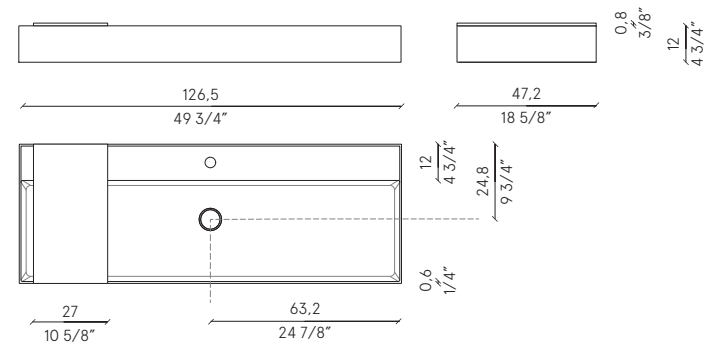

disposizione | layout | disposition | Anordnung | расположение

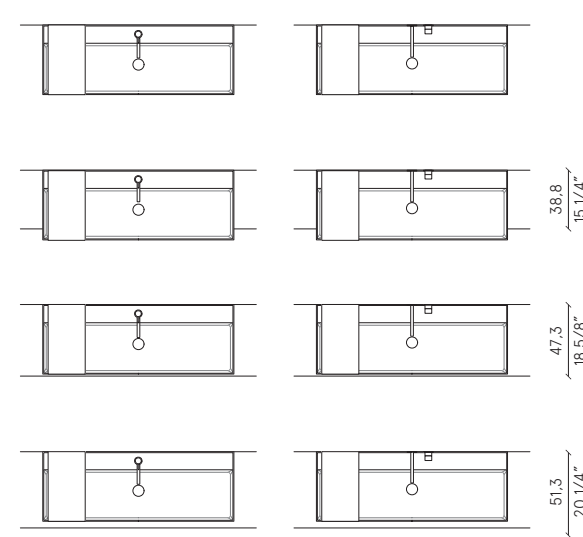

finiture | finishes | finitions | Oberflächen | отделки  
 sintetico opaco | matt synthetic | synthétique mat | Matt Synthetisch | матовое соединение

crystalplant



design Michele Marcon

MAN 126 D

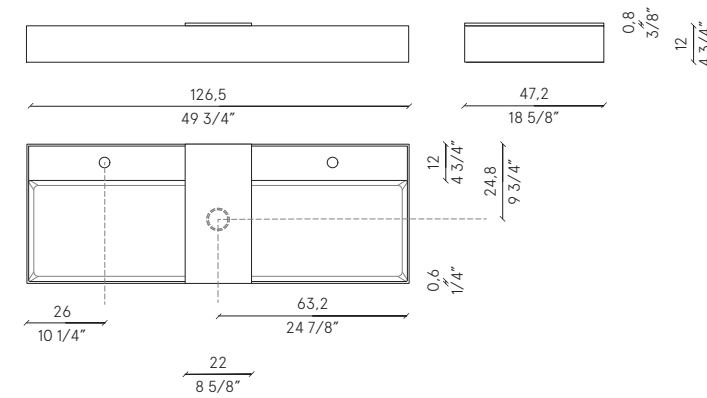

disposizione | layout | disposition | Anordnung | расположение

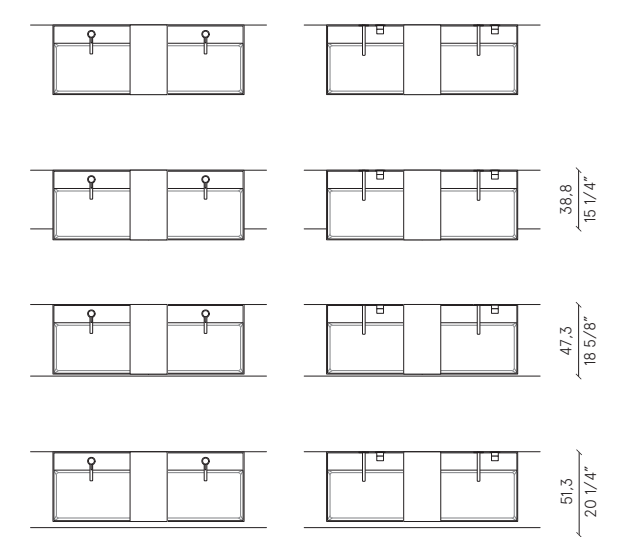

finiture | finishes | finitions | Oberflächen | отделки  
 sintetico opaco | matt synthetic | synthétique mat | Matt Synthetisch | матовое соединение

crystalplant



design Michele Marcon

MAN 144

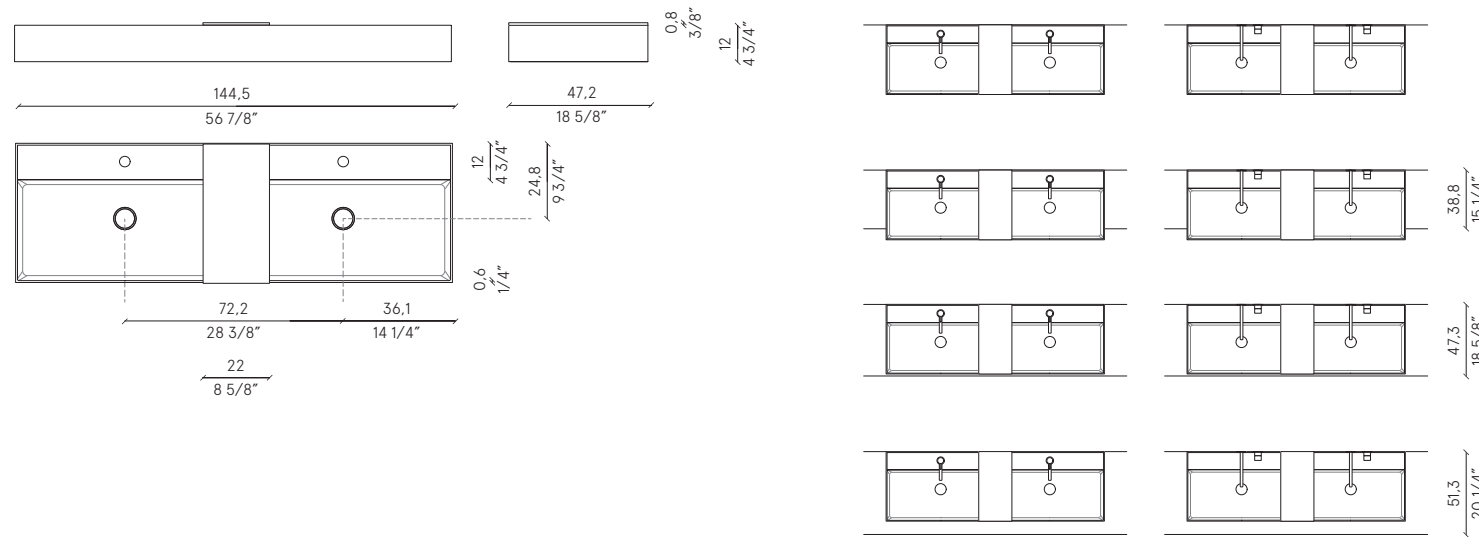

finiture | finishes | finitions | Oberflächen | отделки  
 sintetico opaco | matt synthetic | synthétique mat | Matt Synthetisch | матовое соединение

cristalplant



LOOP

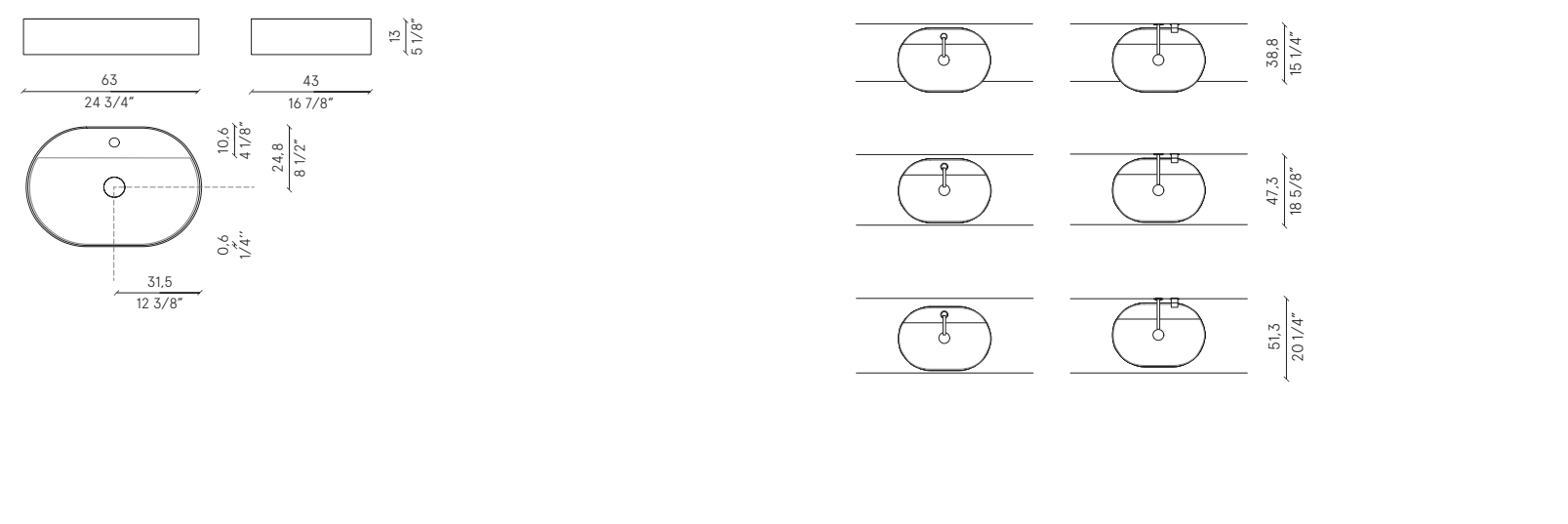

finiture | finishes | finitions | Oberflächen | отделки  
 sintetico opaco | matt synthetic | synthétique mat | Matt Synthetisch | матовое соединение

cristalplant





design Lievore Altherr

AZUMA 45

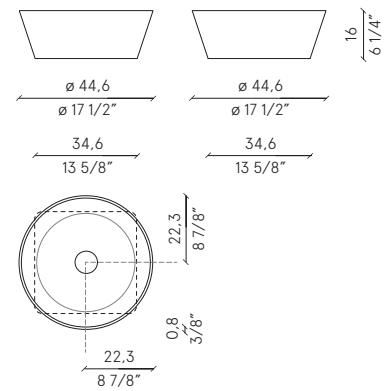

disposizione | layout | disposition | Anordnung | расположение

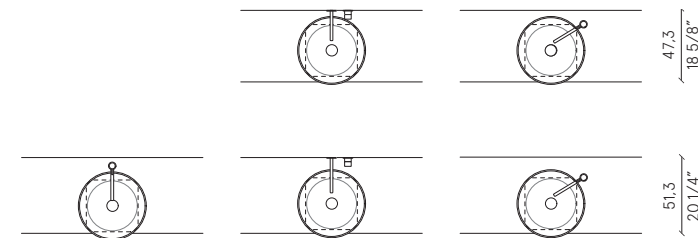

finiture | finishes | finitions | Oberflächen | отделки  
 sintetico opaco | matt synthetic | synthétique mat | Matt Synthetisch | матовое соединение

crystalplant

esterno laccato opaco | Matt lacquered exterior | Extérieur laqué mat | Außenmattlack | Внешняя поверхность в матовой лакировке

22 colours



design Lievore Altherr

AZUMA 58

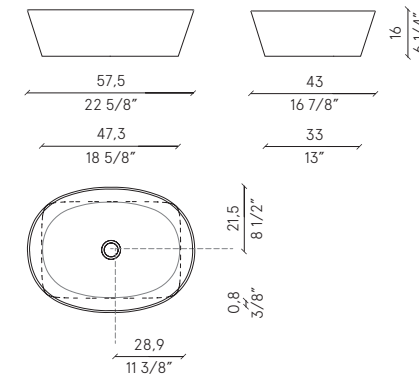

disposizione | layout | disposition | Anordnung | расположение

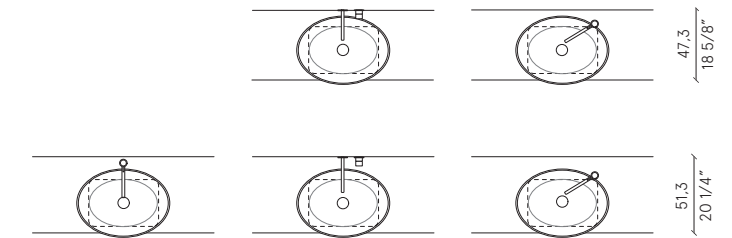

finiture | finishes | finitions | Oberflächen | отделки  
 sintetico opaco | matt synthetic | synthétique mat | Matt Synthetisch | матовое соединение

crystalplant

esterno laccato opaco | Matt lacquered exterior | Extérieur laqué mat | Außenmattlack | Внешняя поверхность в матовой лакировке

22 colours



design Michele Marcon

KEEL 45

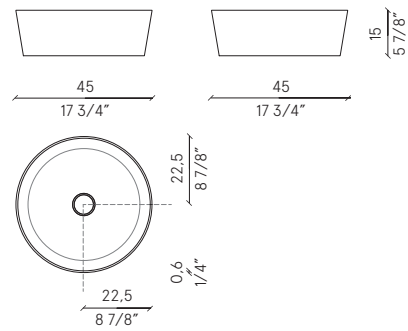

disposizione | layout | disposition | Anordnung | расположение

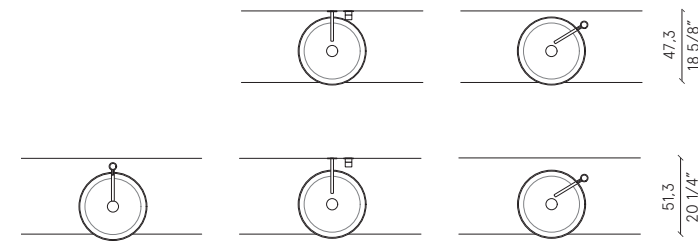

finiture | finishes | finitions | Oberflächen | отделки  
 sintetico opaco | matt synthetic | synthétique mat | Matt Synthetisch | матовое соединение

cristalplant

Cristalplant, esterno laccato opaco | Cristalplant, matt lacquered exterior | Cristalplant, extérieur laqué mat | Cristalplant, Außenmattlack | Cristalplant, Внешняя поверхность в матовой лакировке

22 colours

marmo opaco | matt marble | marbre mat | Matt Marmor | матовый мрамор

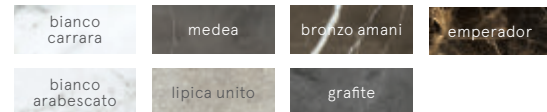

KEEL 60

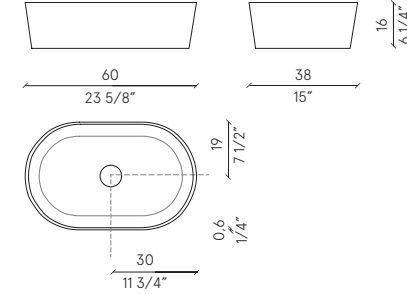

disposizione | layout | disposition | Anordnung | расположение

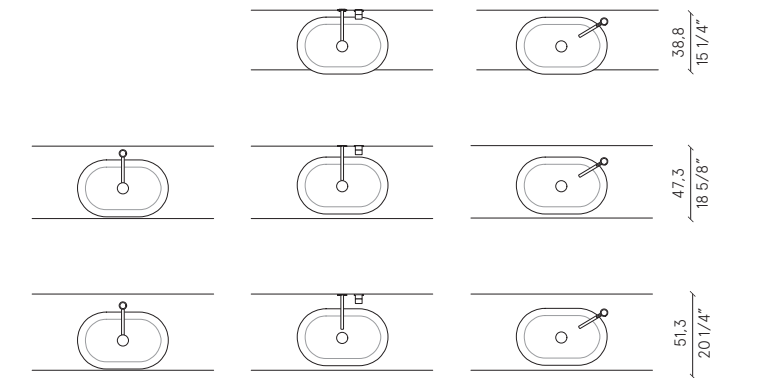

finiture | finishes | finitions | Oberflächen | отделки  
 sintetico opaco | matt synthetic | synthétique mat | Matt Synthetisch | матовое соединение

cristalplant

Cristalplant, esterno laccato opaco | Cristalplant, matt lacquered exterior | Cristalplant, extérieur laqué mat | Cristalplant, Außenmattlack | Cristalplant, Внешняя поверхность в матовой лакировке

22 colours

marmo opaco | matt marble | marbre mat | Matt Marmor | матовый мрамор

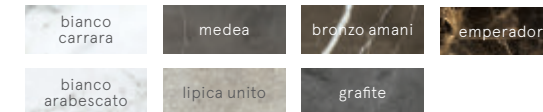





design Michele Marcon

BLEND 63

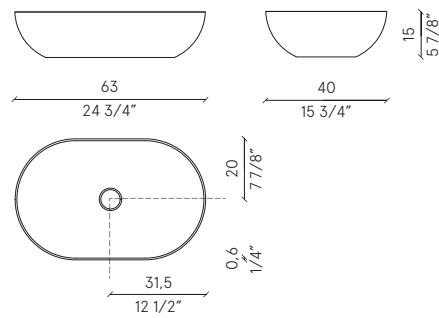

disposizione | layout | disposition | Anordnung | расположение

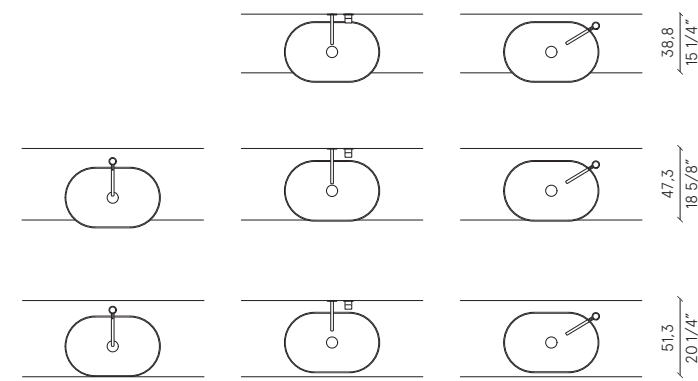

finiture | finishes | finitions | Oberflächen | отделки  
 sintetico opaco | matt synthetic | synthétique mat | Matt Synthetisch | матовое соединение

esterno laccato opaco | Matt lacquered exterior | Extérieur laqué mat | Außenmattlack | Внешняя поверхность в матовой лакировке

cristalplant

22 colours



design Michele Marcon

BLEND 81

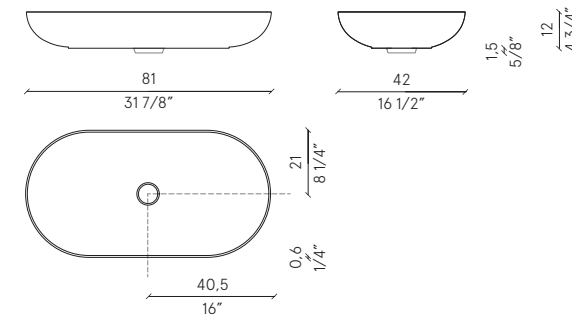

disposizione | layout | disposition | Anordnung | расположение

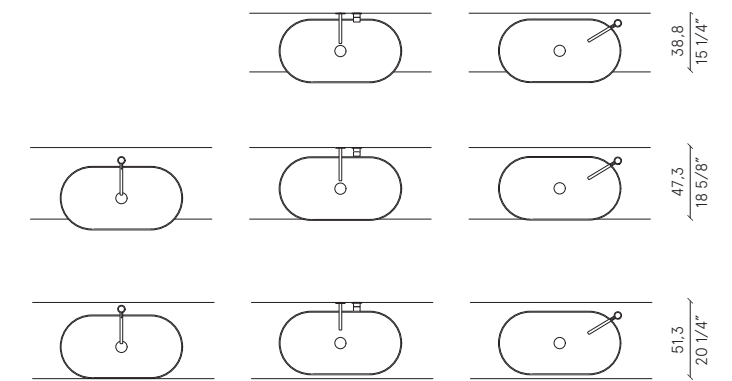

finiture | finishes | finitions | Oberflächen | отделки  
 sintetico opaco | matt synthetic | synthétique mat | Matt Synthetisch | матовое соединение

esterno laccato opaco | Matt lacquered exterior | Extérieur laqué mat | Außenmattlack | Внешняя поверхность в матовой лакировке

cristalplant

22 colours



BOWL 40

disposizione | layout | disposition | Anordnung | расположение

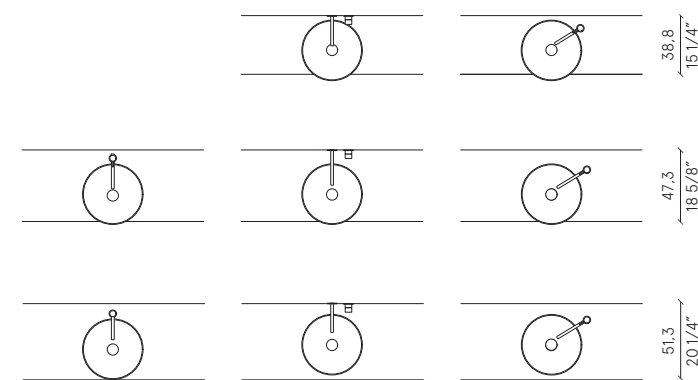
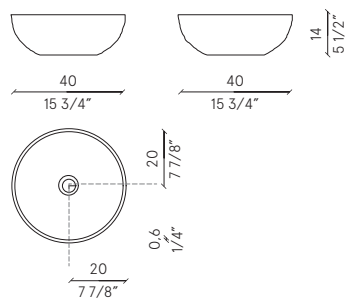

finiture | finishes | finitions | Oberflächen | отделки  
 sintetico opaco | matt synthetic | synthétique mat | Matt Synthetisch | матовое соединение

ceramilux  
matt

esterno laccato opaco | Matt lacquered exterior | Extérieur laqué mat | Außenmattlack | Внешняя  
 поверхность в матовой лакировке

22 colours



design Michele Marcon

BOWL 45

disposizione | layout | disposition | Anordnung | расположение

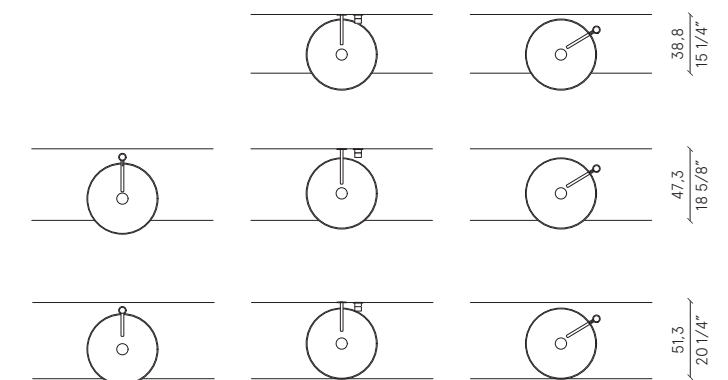
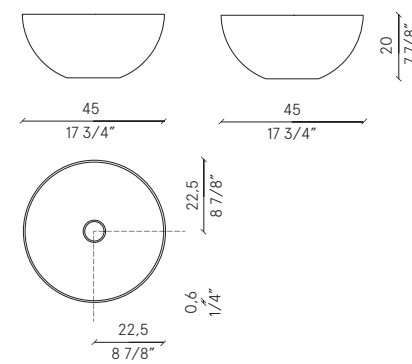

finiture | finishes | finitions | Oberflächen | отделки  
 sintetico opaco | matt synthetic | synthétique mat | Matt Synthetisch | матовое соединение

cristalplant

esterno laccato opaco | Matt lacquered exterior | Extérieur laqué mat | Außenmattlack | Внешняя  
 поверхность в матовой лакировке

22 colours





design Michele Marcon

STEP 45.19

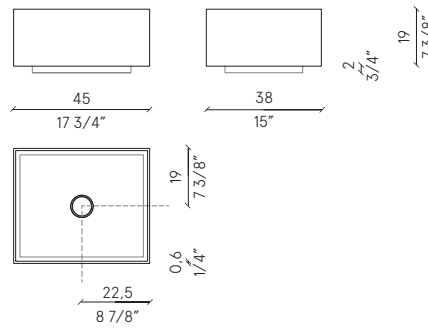

disposizione | layout | disposition | Anordnung | расположение

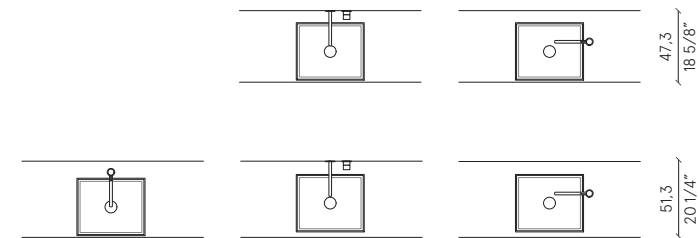

finiture | finishes | finitions | Oberflächen | отделки  
 sintetico opaco | matt synthetic | synthétique mat | Matt Synthetisch | матовое соединение

cristalplant

esterno laccato opaco | Matt lacquered exterior | Extérieur laqué mat | Außenmattlack | Внешняя поверхность в матовой лакировке

22 colours

esterno argilla | clay exterior | extérieur argile | Außenlehm | внешняя поверхность в глине

polvere arena



design Michele Marcon

STEP 45.21

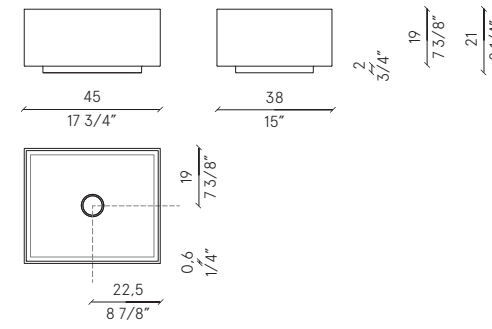

disposizione | layout | disposition | Anordnung | расположение

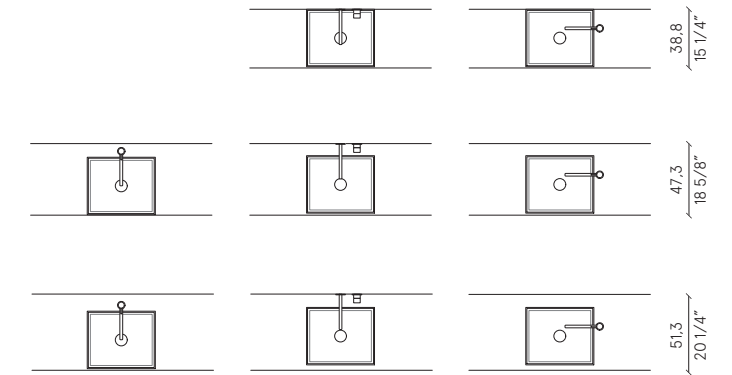

finiture | finishes | finitions | Oberflächen | отделки  
 sintetico opaco | matt synthetic | synthétique mat | Matt Synthetisch | матовое соединение

cristalplant

esterno laccato opaco | Matt lacquered exterior | Extérieur laqué mat | Außenmattlack | Внешняя поверхность в матовой лакировке

22 colours

esterno argilla | clay exterior | extérieur argile | Außenlehm | внешняя поверхность в глине

polvere arena



design Michele Marcon

STEP 63.12

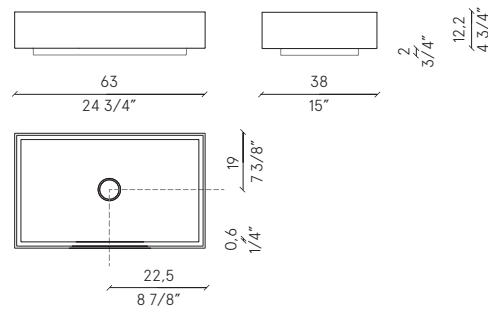

disposizione | layout | disposition | Anordnung | расположение

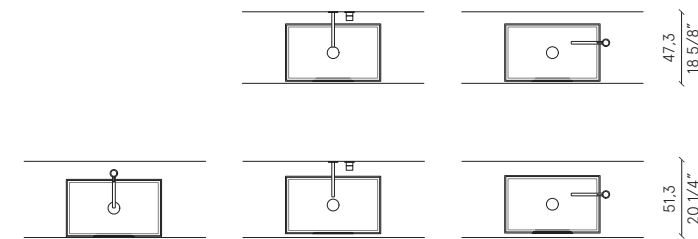

finiture | finishes | finitions | Oberflächen | отделки  
 sintetico opaco | matt synthetic | synthétique mat | Matt Synthetisch | матовое соединение

cristalplant

esterno laccato opaco | Matt lacquered exterior | Extérieur laqué mat | Außenmattlack | Внешняя поверхность в матовой лакировке

22 colours

esterno argilla | clay exterior | extérieur argile | Außenlehm | внешняя поверхность в глине

polvere arena



design Michele Marcon

STEP 63.14

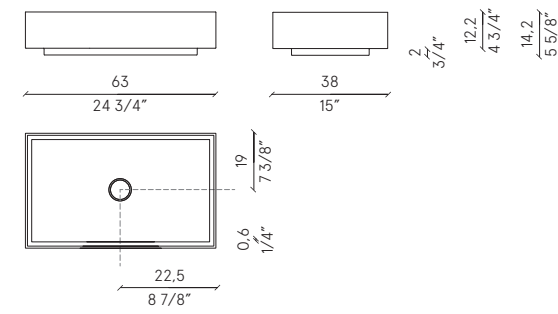

disposizione | layout | disposition | Anordnung | расположение

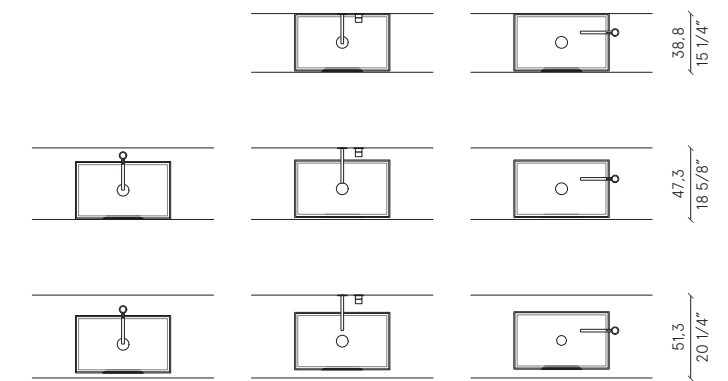

finiture | finishes | finitions | Oberflächen | отделки  
 sintetico opaco | matt synthetic | synthétique mat | Matt Synthetisch | матовое соединение

cristalplant

esterno laccato opaco | Matt lacquered exterior | Extérieur laqué mat | Außenmattlack | Внешняя поверхность в матовой лакировке

22 colours

esterno argilla | clay exterior | extérieur argile | Außenlehm | внешняя поверхность в глине

polvere arena





BASIC Q37

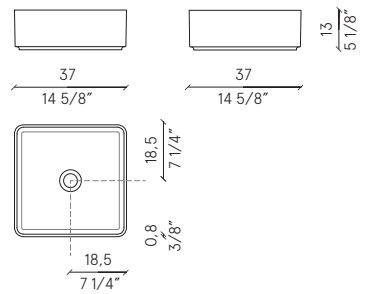

disposizione | layout | disposition | Anordnung | расположение

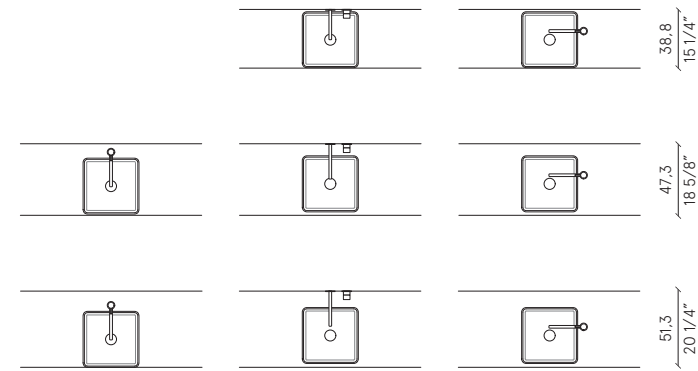

finiture | finishes | finitions | Oberflächen | отделки  
 sintetico opaco | matt synthetic | synthétique mat | Matt Synthetisch | матовое соединение

ceramilux  
matt

esterno laccato opaco | Matt lacquered exterior | Extérieur laqué mat | Außenmattlack | Внешняя поверхность в матовой лакировке

22 colours



BASIC R58

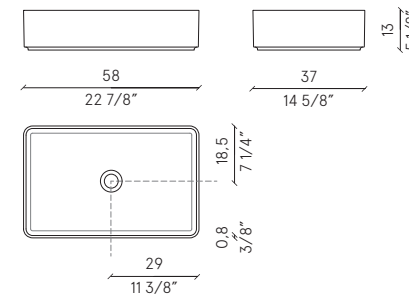

disposizione | layout | disposition | Anordnung | расположение

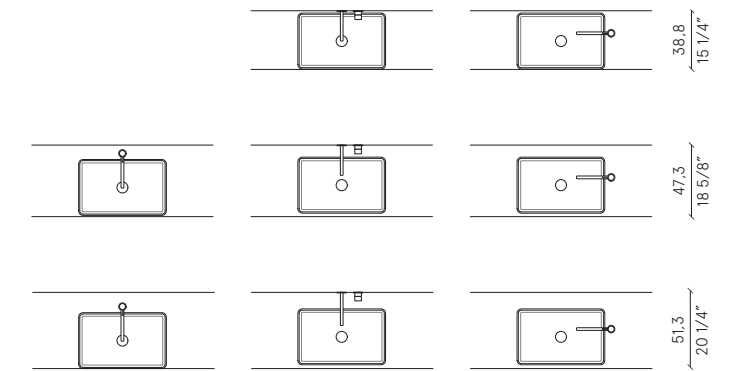

finiture | finishes | finitions | Oberflächen | отделки  
 sintetico opaco | matt synthetic | synthétique mat | Matt Synthetisch | матовое соединение

ceramilux  
matt

esterno laccato opaco | Matt lacquered exterior | Extérieur laqué mat | Außenmattlack | Внешняя поверхность в матовой лакировке

22 colours



BASIC C37

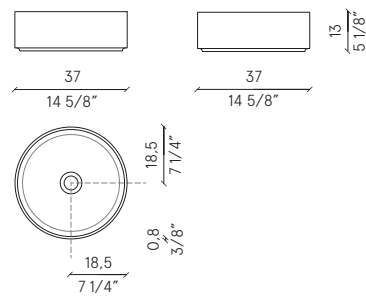

disposizione | layout | disposition | Anordnung | расположение

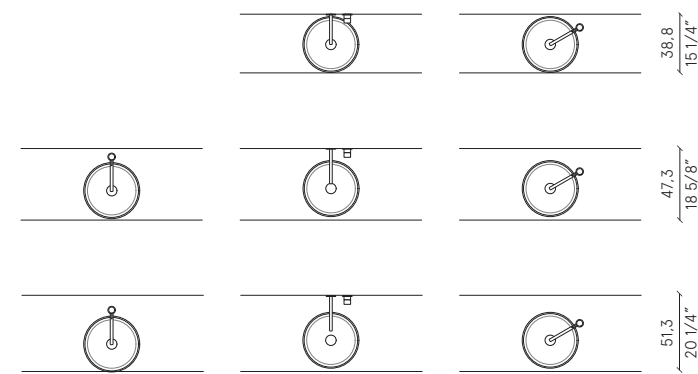

finiture | finishes | finitions | Oberflächen | отделки  
 sintetico opaco | matt synthetic | synthétique mat | Matt Synthetisch | матовое соединение

ceramilux  
 matt

esterno laccato opaco | Matt lacquered exterior | Extérieur laqué mat | Außenmattlack | Внешняя поверхность в матовой лакировке

22 colori



design Lino Codato

SKA

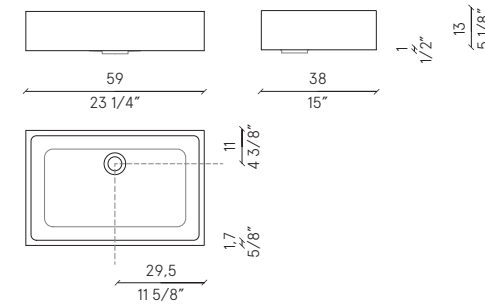

disposizione | layout | disposition | Anordnung | расположение

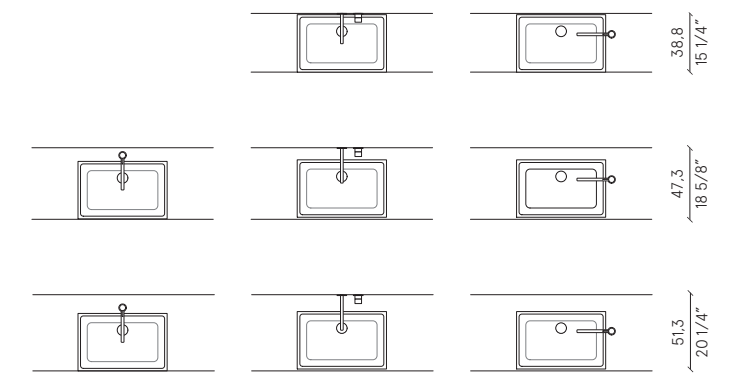

finiture | finishes | finitions | Oberflächen | отделки  
 sintetico opaco | matt synthetic | synthétique mat | Matt Synthetisch | матовое соединение

ceramilux  
 matt





DEN E60

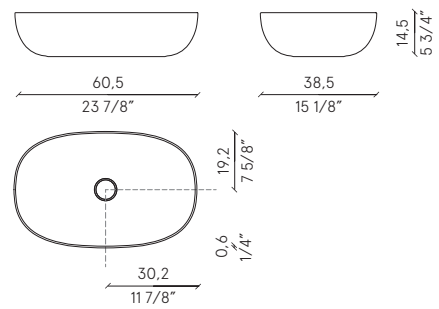

disposizione | layout | disposition | Anordnung | расположение

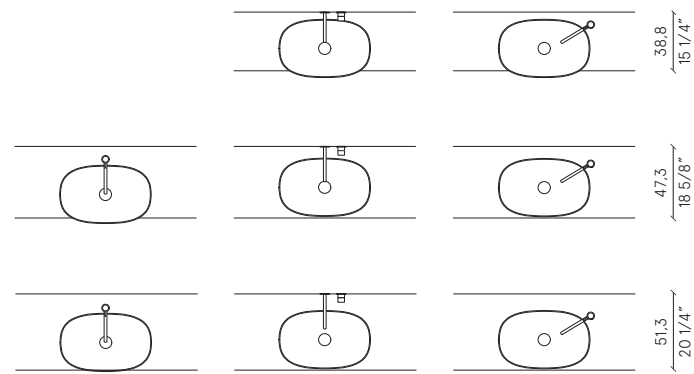

finiture | finishes | finitions | Oberflächen | отделки  
 ceramica lucida | glossy ceramic | céramique brillante | glänzende Keramik | глянцевая керамика

bianco



DEN C45

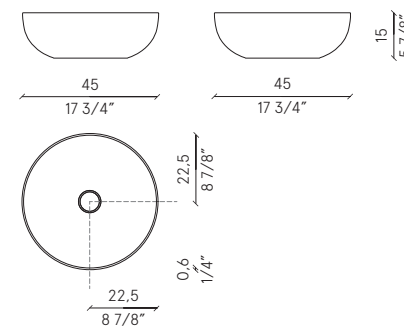

disposizione | layout | disposition | Anordnung | расположение

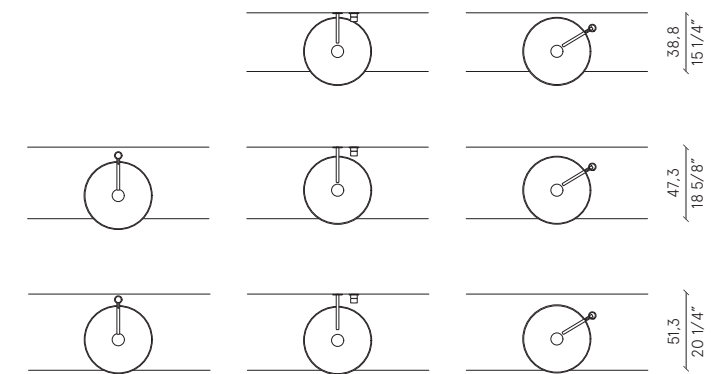

finiture | finishes | finitions | Oberflächen | отделки  
 ceramica lucida | glossy ceramic | céramique brillante | glänzende Keramik | глянцевая керамика

bianco



DEN R50

disposizione | layout | disposition | Anordnung | расположение

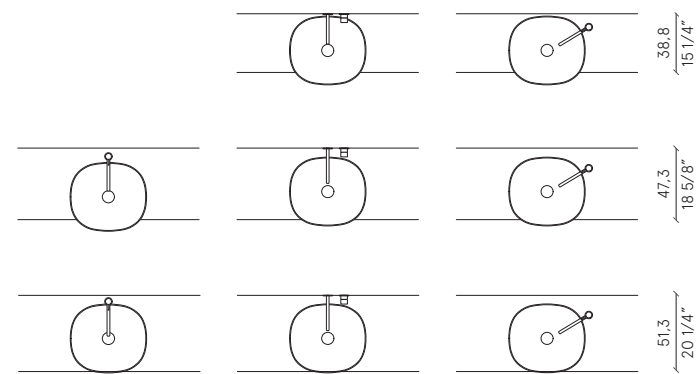
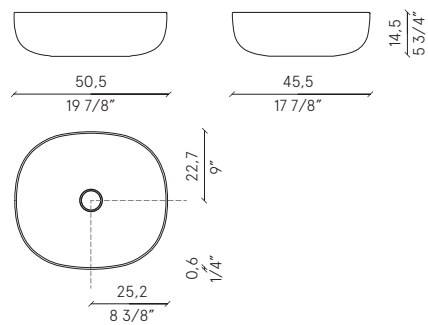

finiture | finishes | finitions | Oberflächen | отделки  
ceramica lucida | glossy ceramic | céramique brillante | glänzende Keramik | глянецовая керамика

bianco



DEN Q42

disposizione | layout | disposition | Anordnung | расположение

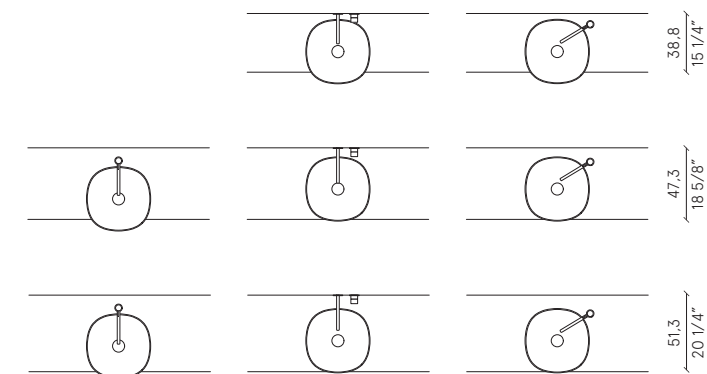
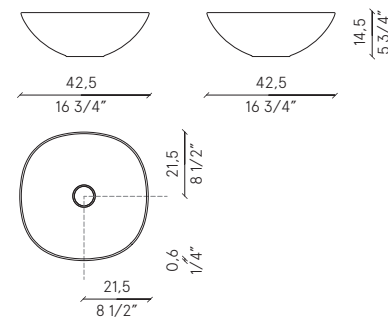

finiture | finishes | finitions | Oberflächen | отделки  
ceramica lucida | glossy ceramic | céramique brillante | glänzende Keramik | глянецовая керамика

bianco





design Lievore Altherr

ROMA 16

disposizione | layout | disposition | Anordnung | расположение

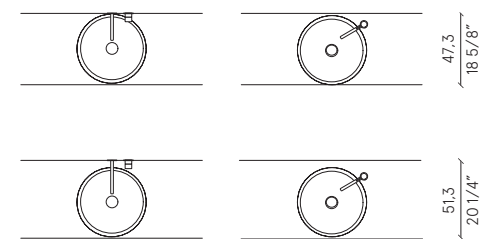
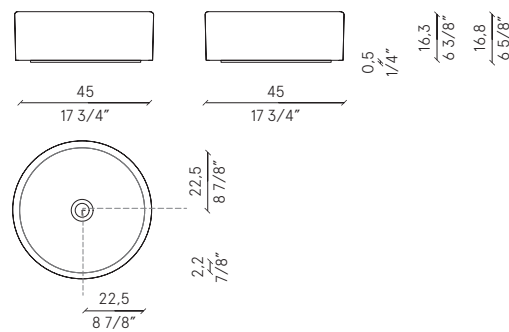

finiture | finishes | finitions | Oberflächen | отделки  
ceramica opaca | matt ceramic | céramique mate | Mattkeramik | матовая керамика



design Lievore Altherr

ROMA 25

disposizione | layout | disposition | Anordnung | расположение

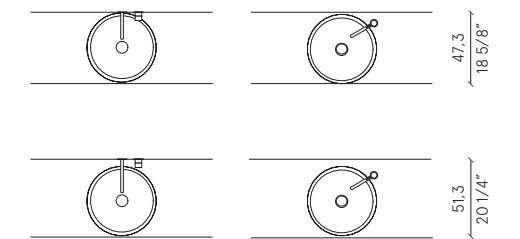
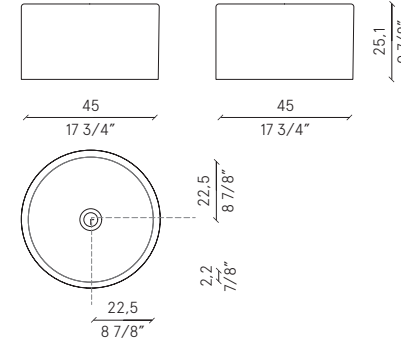

finiture | finishes | finitions | Oberflächen | отделки  
ceramica opaca | matt ceramic | céramique mate | Mattkeramik | матовая керамика

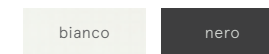



WORLD

disposizione | layout | disposition | Anordnung | расположение

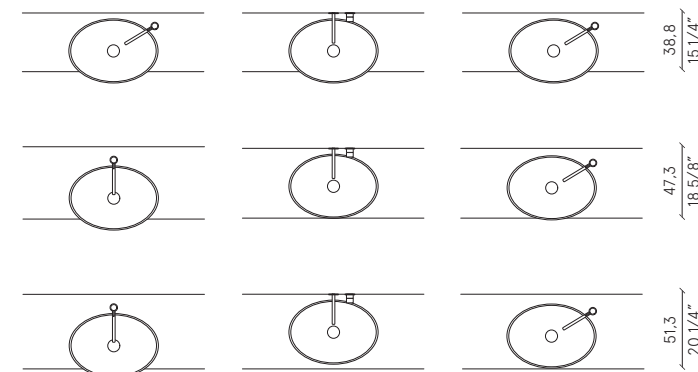
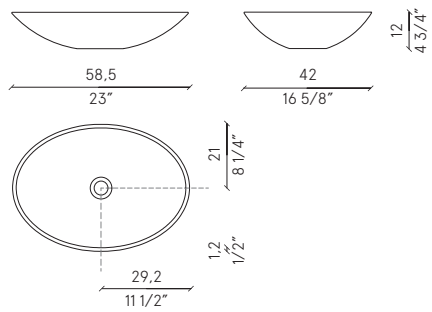

finiture | finishes | finitions | Oberflächen | отделки  
 sintetico opaco | matt synthetic | synthétique mat | Matt Synthetisch | матовое соединение

ceramilux  
matt



BASIC R58

disposizione | layout | disposition | Anordnung | расположение

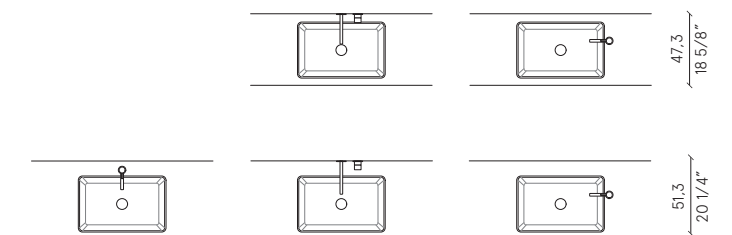
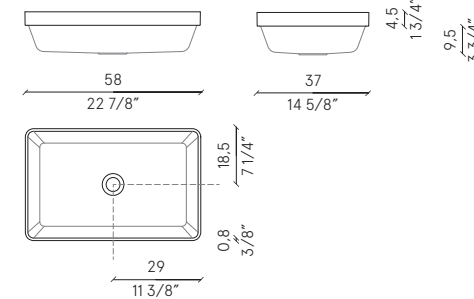

finiture | finishes | finitions | Oberflächen | отделки  
 sintetico opaco | matt synthetic | synthétique mat | Matt Synthetisch | матовое соединение

ceramilux  
matt





design Lino Codato

SKA

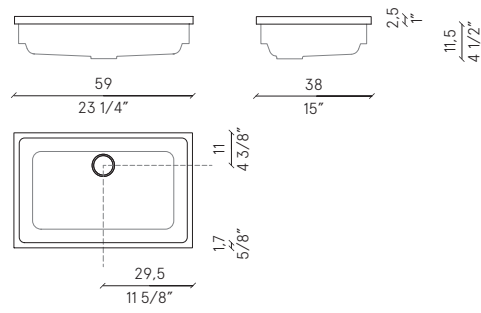

disposizione | layout | disposition | Anordnung | расположение

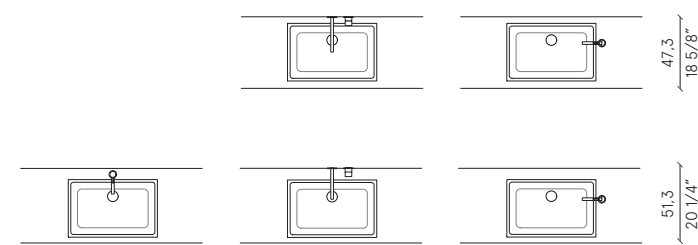

finiture | finishes | finitions | Oberflächen | отделки  
 sintetico opaco | matt synthetic | synthétique mat | Matt Synthetisch | матовое соединение

ceramilux  
 matt



design Michele Marcon

NET 54.37

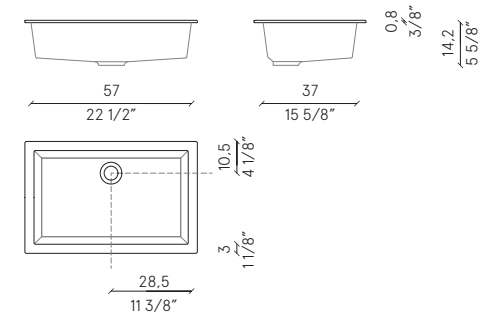

disposizione | layout | disposition | Anordnung | расположение

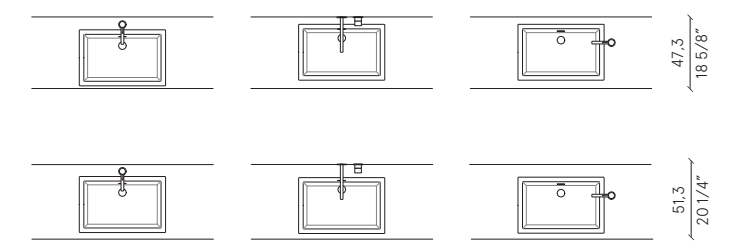

finiture | finishes | finitions | Oberflächen | отделки  
 ceramica lucida | glossy ceramic | céramique brillante | glänzende Keramik | глянецовая керамика

bianco



design Michele Marcon

NET 54.31

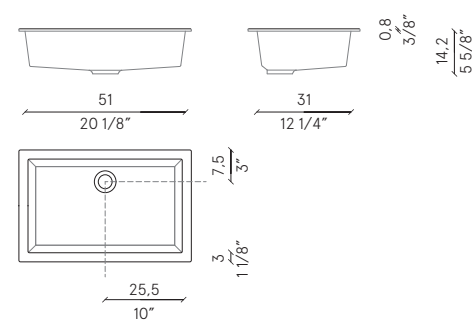

disposizione | layout | disposition | Anordnung | расположение

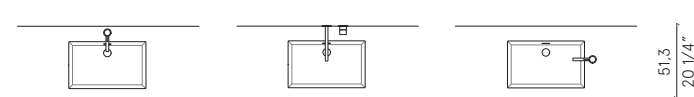

finiture | finishes | finitions | Oberflächen | отделки  
 ceramica lucida | glossy ceramic | céramique brillante | glänzende Keramik | глянецовая керамика

bianco



NET 47

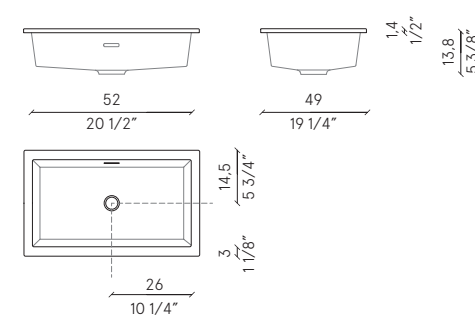

disposizione | layout | disposition | Anordnung | расположение

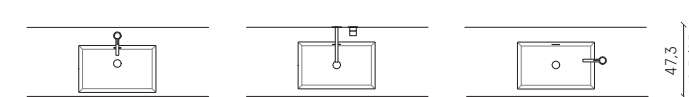

finiture | finishes | finitions | Oberflächen | отделки  
 ceramica lucida | glossy ceramic | céramique brillante | glänzende Keramik | глянецовая керамика

bianco





design Lino Codato

SKA

disposizione | layout | disposition | Anordnung | расположение

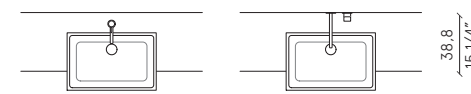
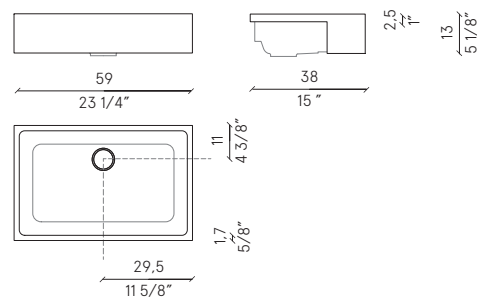

finiture | finishes | finitions | Oberflächen | отделки  
 sintetico opaco | matt synthetic | synthétique mat | Matt Synthetisch | матовое соединение

ceramilux  
matt



design Michele Marcon

PROP 49

disposizione | layout | disposition | Anordnung | расположение

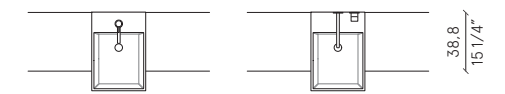
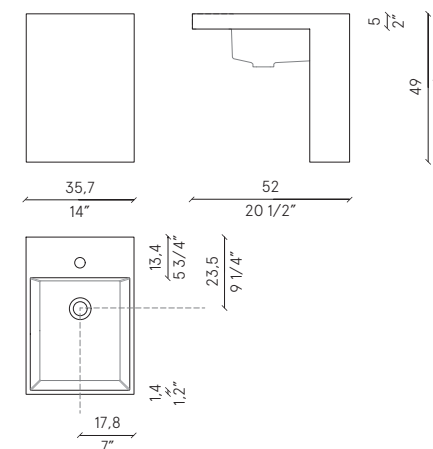

finiture | finishes | finitions | Oberflächen | отделки  
 sintetico opaco | matt synthetic | synthétique mat | Matt Synthetisch | матовое соединение

milltek  
solid



TUBE

disposizione | layout | disposition | Anordnung | расположение

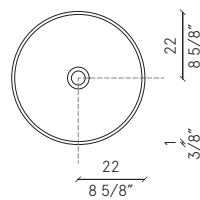
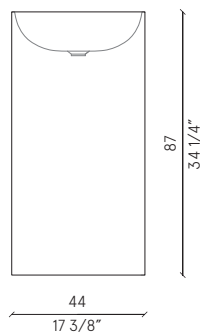

finiture | finishes | finitions | Oberflächen | отделки  
 sintetico opaco | matt synthetic | synthétique mat | Matt Synthetisch | матовое соединение

cristalplant

esterno laccato opaco | Matt lacquered exterior | Extérieur laqué mat | Außenmattlack | Внешняя  
 поверхность в матовой лакировке



design Lievore Altherr

AZUMA 88

disposizione | layout | disposition | Anordnung | расположение

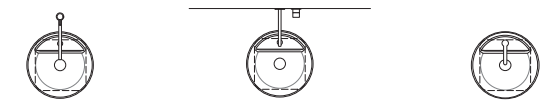
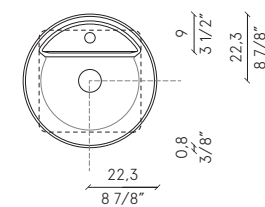
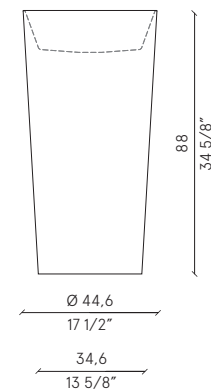

finiture | finishes | finitions | Oberflächen | отделки  
 sintetico opaco | matt synthetic | synthétique mat | Matt Synthetisch | матовое соединение

cristalplant

esterno laccato opaco | Matt lacquered exterior | Extérieur laqué mat | Außenmattlack | Внешняя  
 поверхность в матовой лакировке







design Lievore Altherr

ROMA I disposizione | layout | disposition | Anordnung | расположение

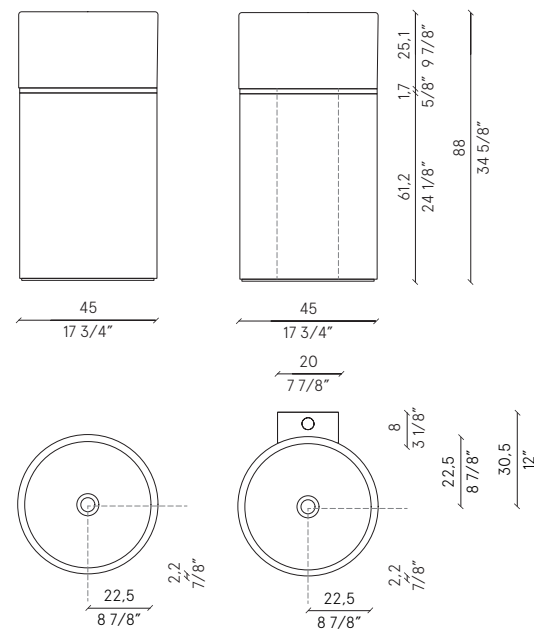

finiture | finishes | finitions | Oberflächen | отделки  
ceramica opaca | matt ceramic | céramique mate | Mattkeramik | матовая керамика

bianco | nero

fascia | strip | bande | band | полка

platino | oro satinato

essenze | veneers | essences | Holze | шпоны

noce canaletto | rovere mezza fiamma | rovere nero

combinazioni | combinations | combinaisons | Kombinationen | комбинации



lavabo ceramica opaca, fascia, parte inferiore essenza  
matt ceramic washbasin, strip, wooden lower strip  
vasque en céramique mate, bande, bande inférieure en bois  
Mattes Keramik-Waschbecken, band, unterer Teil aus Holz  
матовая керамическая раковина, полоса, нижняя деревянная полоса



design Lievore Altherr

ROMA II disposizione | layout | disposition | Anordnung | расположение

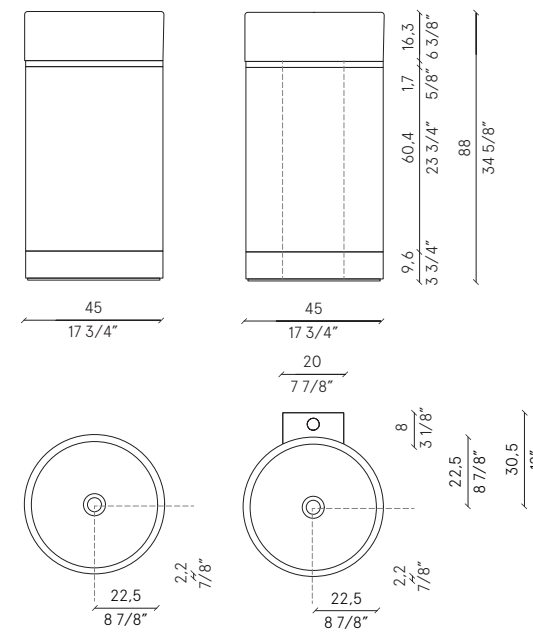

finiture | finishes | finitions | Oberflächen | отделки  
ceramica opaca | matt ceramic | céramique mate | Mattkeramik | матовая керамика

bianco | nero

fascia | strip | bande | band | полка

platino | oro satinato

essenze | veneers | essences | Holze | шпоны

noce canaletto | rovere mezza fiamma | rovere nero

combinazioni | combinations | combinaisons | Kombinationen | комбинации



lavabo ceramica opaca, fascia, parte inferiore e zoccolo in essenza  
matt ceramic washbasin, strip, wooden lower strip and plinth  
vasque en céramique mate, bande, bande inférieure et socle en bois  
Mattes Keramikwaschbecken, band, Unterteil und Fuß aus Holz  
матовая керамическая раковина, полоса, нижняя деревянная полоса и деревянный цоколь



design Lievore Altherr

ROMA III

disposizione | layout | disposition | Anordnung | расположение

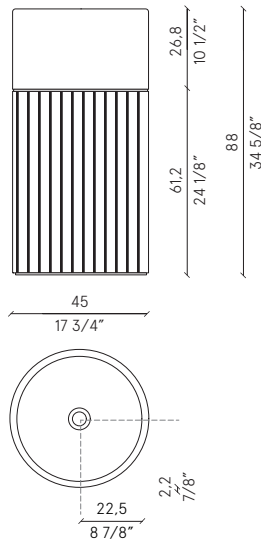

finiture | finishes | finitions | Oberflächen | отделки  
 marmo opaco | matt marble | marbre mat | Matt Marmor | матовый мрамор



combinazioni | combinations | combinaisons | Kombinationen | комбинации

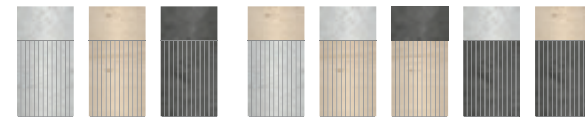

lavabo liscio, parte inferiore con fresatura irregolare  
 smooth washbasin, irregular milled lower strip  
 vasque polie, bande inférieure avec fraisée irrégulière  
 glattes Waschbecken, unterer Teil mit unregelmäßiger Fräsung  
 полированная раковина, фрезеровкой нижней частью



design Lievore Altherr

ROMA IV

disposizione | layout | disposition | Anordnung | расположение

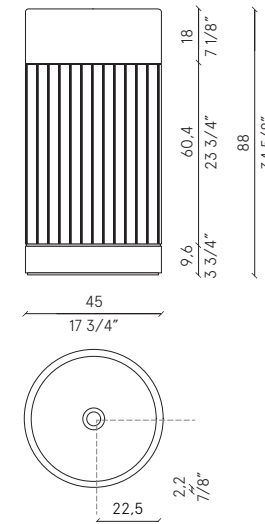

finiture | finishes | finitions | Oberflächen | отделки  
 marmo opaco | matt marble | marbre mat | Matt Marmor | матовый мрамор

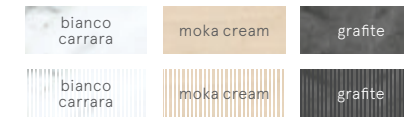

combinazioni | combinations | combinaisons | Kombinationen | комбинации

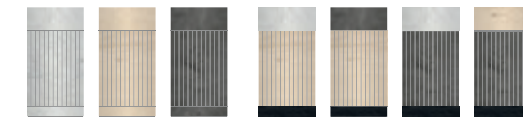

pietra a spacco | split stone | pierre fendue | Spaltstein | камень с отделкой рваные/расколотая камень

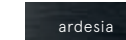

lavabo liscio, parte inferiore con fresatura irregolare, zoccolo liscio o a spacco in Ardesia  
 smooth washbasin, irregular milled lower strip, smooth or rough split plinth in Ardesia  
 vasque polie, bande inférieure avec fraisée irrégulière, socle poli ou fendu en Ardesia  
 glattes Waschbecken, unterer Teil mit unregelmäßiger Fräsung, glatter oder geteilter Sockel aus Ardesia  
 полированная раковина, фрезеровкой нижней частью, полированный цоколь или с отделкой рваные края из Ardesia





design Michele Marcon

INFINITY

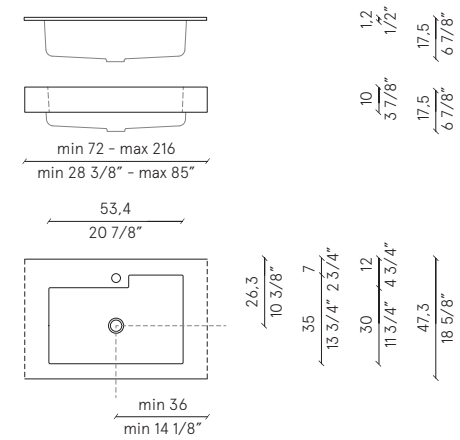

finiture | finishes | finitions | Oberflächen | отделки  
 sintetici opachi | matt compounds | synthétiques mates | Matt Kunststoff | матовые соединения

- milltek solid
- milltek gel

sintetici lucidi | glossy synthetics | synthétiques brilliants | glänzende Synthetische  
 Глянцевые соединения

- milltek gel

due vasche | two basins | deux vasques | zwei Becken | две раковины  
 L top | W top | L plan | B Platte | Ш столешница

Infinity + Infinity = min 144 cm | 56 3/4"

top | plan | Platte | столешница  
 sp. | th. | sp. | Di. | тол.

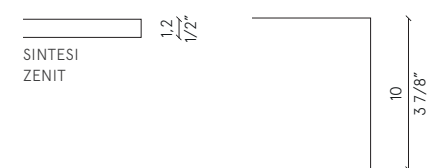



LAYER 01 | LAYER 02

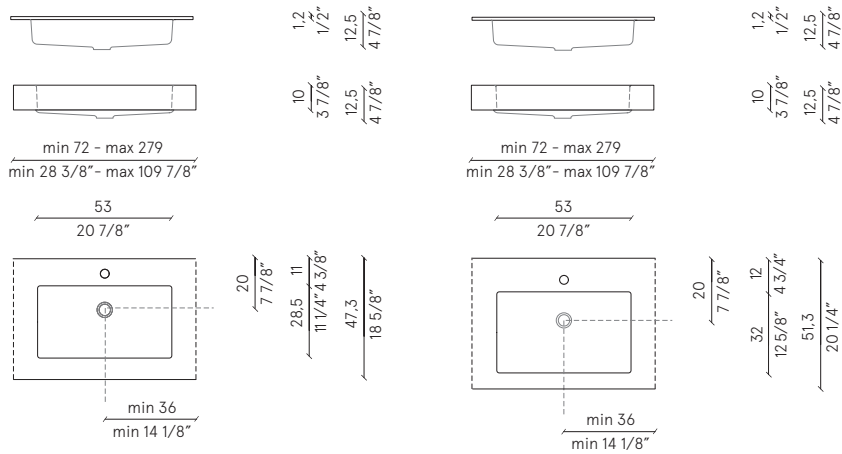

finiture | finishes | finitions | Oberflächen | отделки  
 sinteticici opachi e lucidi | matt and glossy synthetics | synthétiques mates et brillantes | Matt und glänzende Synthetische | матовые лакировки и брашированные глянцевые лакировки

milltek  
 solid light

top laminato, lavabo sintetico opaco | laminated top, matt synthetic washbasin  
 plan mélamin, vasque synthétique mate | Platt aus Laminat, Waschbecken auf matt Synthetisch | столешница из ламината, раковина из матовых соединения

ares fango ares argilla

due vasche | two basins | deux vasques | zwei Becken | две раковины  
 L top | W top | L plan | B Platte | Ш столешница

Layer 01 + Layer 01 = min 144 cm | 56 3/4"  
 Layer 02 + Layer 02 = min 144 cm | 56 3/4"

top | plan | Platte | столешница  
 sp. | th. | sp. | Di. | тол.

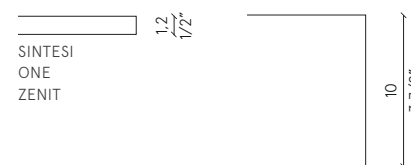

LAYER 01 | LAYER 02

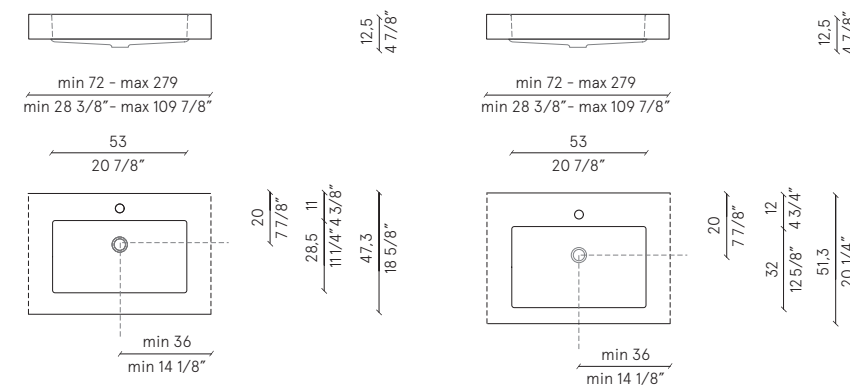

finiture | finishes | finitions | Oberflächen | отделки  
 sinteticici opachi e lucidi | matt and glossy synthetics | synthétiques mates et brillantes | Matt und glänzende Synthetische | матовые лакировки и брашированные глянцевые лакировки

milltek  
 solid light

top laminato, lavabo sintetico opaco | laminated top, matt synthetic washbasin  
 plan mélamin, vasque synthétique mate | Platt aus Laminat, Waschbecken auf matt Synthetisch | столешница из ламината, раковина из матовых соединения

ares fango ares argilla

due vasche | two basins | deux vasques | zwei Becken | две раковины  
 L top | W top | L plan | B Platte | Ш столешница

Layer 01 + Layer 01 = min 144 cm | 56 3/4"  
 Layer 02 + Layer 02 = min 144 cm | 56 3/4"

top | plan | Platte | столешница  
 sp. | th. | sp. | Di. | тол.

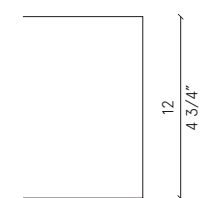





STAGE 01 | STAGE 02 | STAGE 04 | STAGE 06

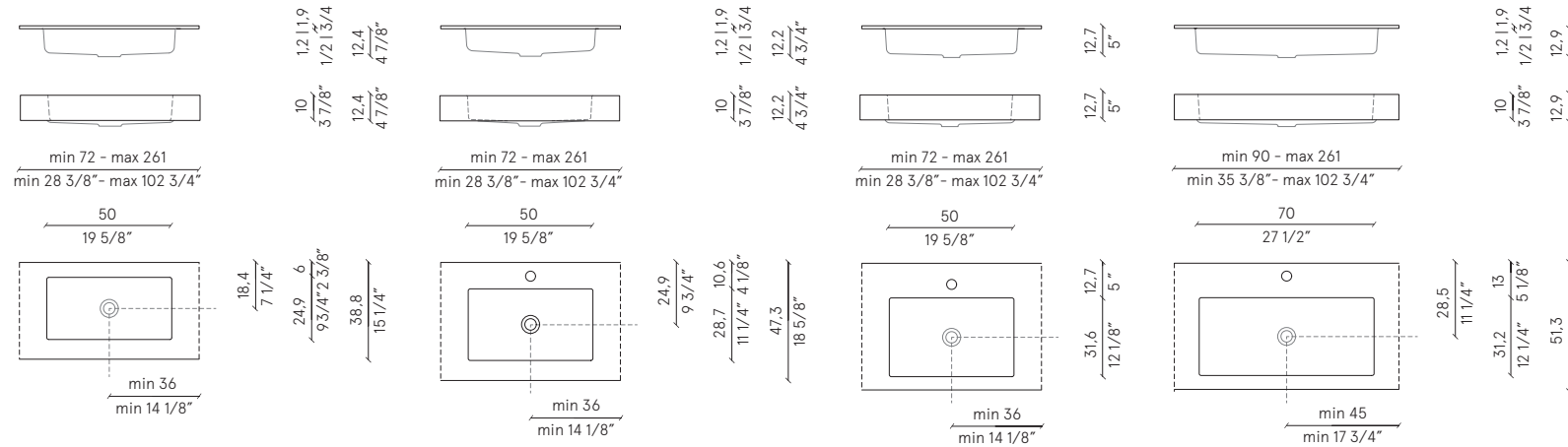

finiture | finishes | finitions | Oberflächen | отделки  
 sintetici opachi | matt compounds | synthétiques mates | Matt Kunststoff | матовые соединений

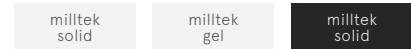

sintetici lucidi | glossy synthetics | synthétiques brilliants | glänzende Synthetische  
 Глянцевые соединений



due vasche | two basins | deux vasques | zwei Becken | две раковины  
 L top | W top | L plan | B Platte | Ш столешница

Stage 01 + Stage 01 = min 144 cm | 56 3/4"  
 Stage 02 + Stage 02 = min 144 cm | 56 3/4"  
 Stage 04 + Stage 04 = min 144 cm | 56 3/4"  
 Stage 06 + Stage 06 = min 180 cm | 70 7/8"

top | plan | Platte | столешница  
 sp. lth. | sp. | Di. | тол.

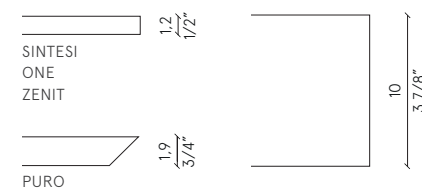

STAGE 01 | STAGE 02 | STAGE 04 | STAGE 06

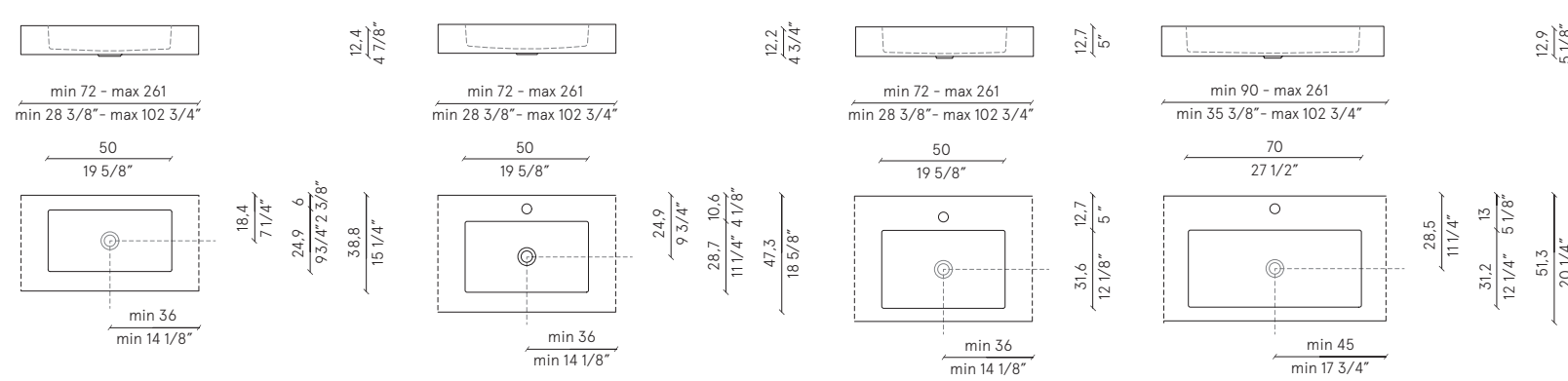

finiture | finishes | finitions | Oberflächen | отделки  
 sintetici opachi | matt compounds | synthétiques mates | Matt Kunststoff | матовые соединений

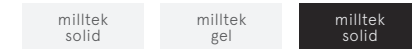

sintetici lucidi | glossy synthetics | synthétiques brilliants | glänzende Synthetische  
 Глянцевые соединений

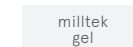

due vasche | two basins | deux vasques | zwei Becken | две раковины  
 L top | W top | L plan | B Platte | Ш столешница

Stage 01 + Stage 01 = min 144 cm | 56 3/4"  
 Stage 02 + Stage 02 = min 144 cm | 56 3/4"  
 Stage 04 + Stage 04 = min 144 cm | 56 3/4"  
 Stage 06 + Stage 06 = min 180 cm | 70 7/8"

top | plan | Platte | столешница  
 sp. lth. | sp. | Di. | тол.

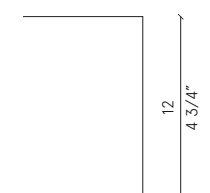



NEAT 01 | NEAT 02

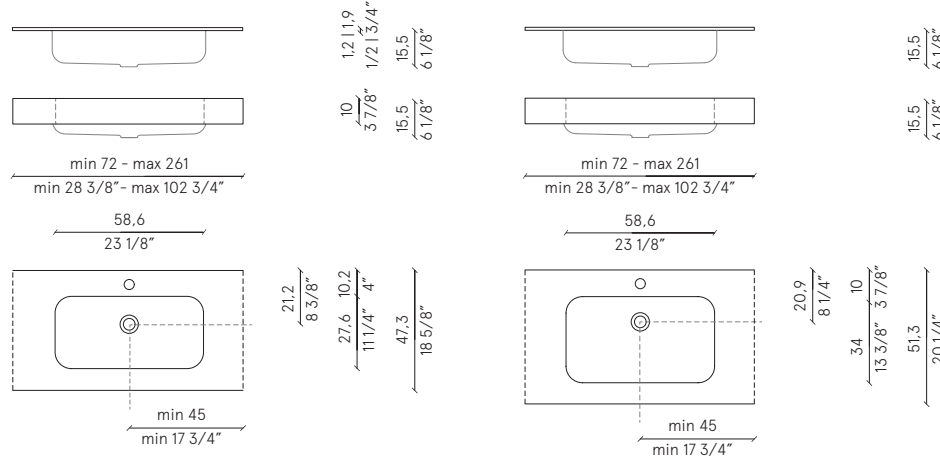

finiture | finishes | finitions | Oberflächen | отделки  
 sintetici opraci | matt compounds | synthétiques mates | Matt Kunststoff | матовые соединения

- milltek solid
- milltek gel

sintetici lucidi | glossy synthetics | synthétiques brilliants | glänzende Synthetische  
 Глянцевые соединения

- milltek gel

due vasche | two basins | deux vasques | zwei Becken | две раковины  
 L top | W top | L plan | B Platte | Ш столешница

Neat 01 + Neat 01 = min 144 cm | 56 3/4"  
 Neat 02 + Neat 02 = min 144 cm | 56 3/4"

top | plan | Platte | столешница  
 sp. | th. | sp. | Di. | тол.

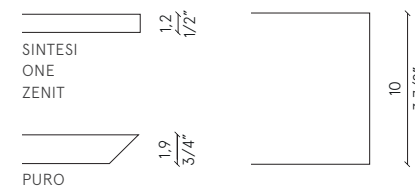

NEAT 01 | NEAT 02

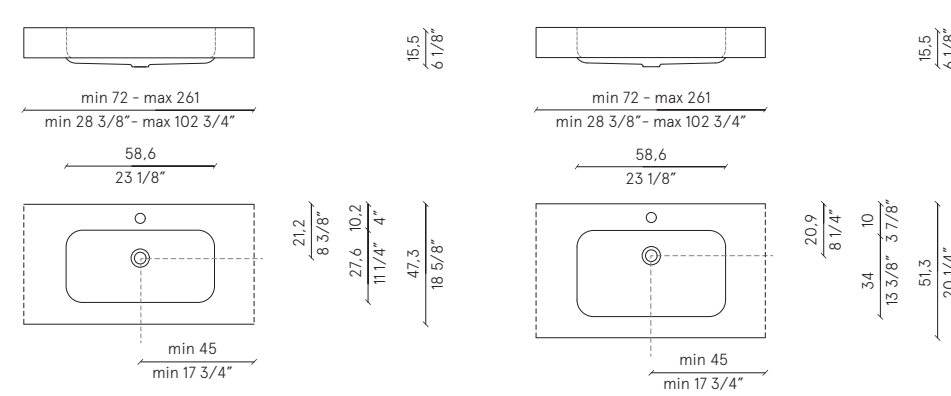

finiture | finishes | finitions | Oberflächen | отделки  
 sintetici opraci | matt compounds | synthétiques mates | Matt Kunststoff | матовые соединения

- milltek solid
- milltek gel

sintetici lucidi | glossy synthetics | synthétiques brilliants | glänzende Synthetische  
 Глянцевые соединения

- milltek gel

due vasche | two basins | deux vasques | zwei Becken | две раковины  
 L top | W top | L plan | B Platte | Ш столешница

Neat 01 + Neat 01 = min 144 cm | 56 3/4"  
 Neat 02 + Neat 02 = min 144 cm | 56 3/4"

top | plan | Platte | столешница  
 sp. | th. | sp. | Di. | тол.

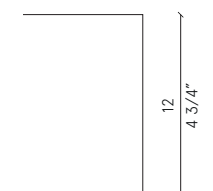





ROUND 01 | ROUND 02

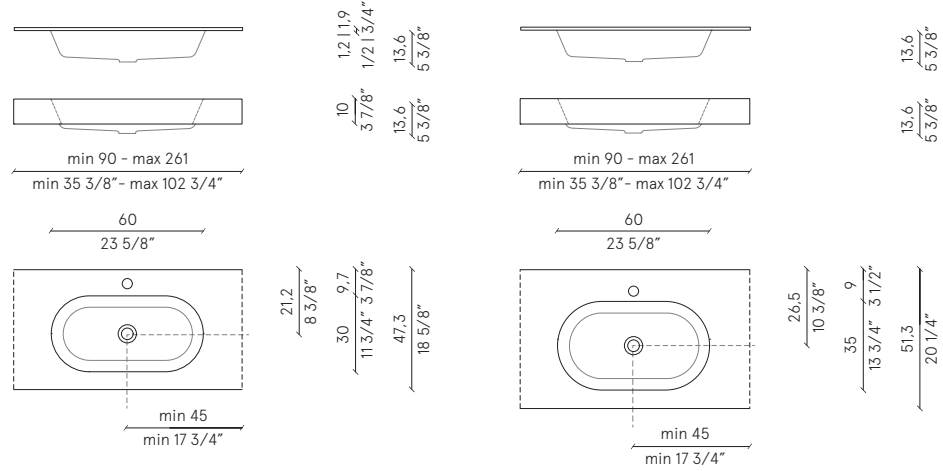

finiture | finishes | finitions | Oberflächen | отделки  
 sintetici opachi | matt compounds | synthétiques mates | Matt Kunststoff | матовые соединения

milltek solid milltek gel

sintetici lucidi | glossy synthetics | synthétiques brilliants | glänzende Synthetische  
 Глянцевые соединения

milltek gel

due vasche | two basins | deux vasques | zwei Becken | две раковины  
 L top | W top | L plan | B Platte | Ш столешница

Round 01 + Round 01 = min 180 cm | 70 7/8"  
 Round 02 + Round 02 = min 180 cm | 70 7/8"

top | plan | Platte | столешница  
 sp. | th. | sp. | Di. | тол.

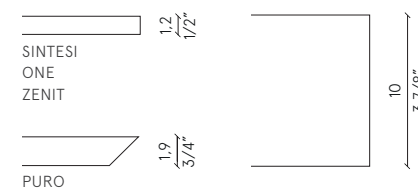

ROUND 01 | ROUND 02

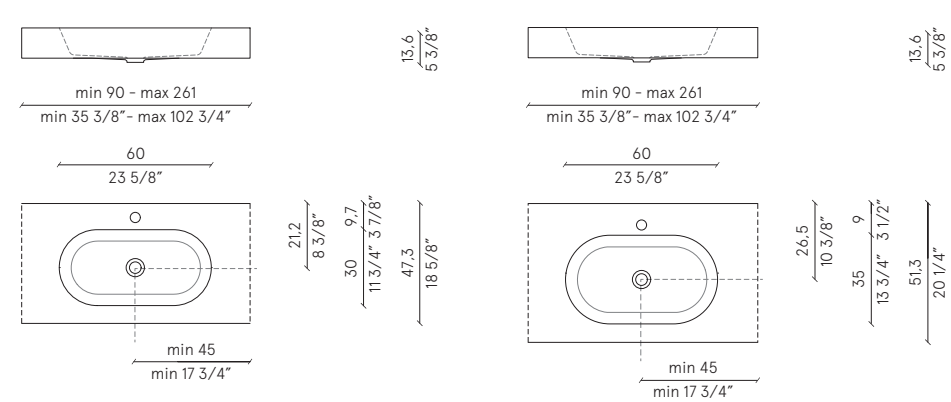

finiture | finishes | finitions | Oberflächen | отделки  
 sintetici opachi | matt compounds | synthétiques mates | Matt Kunststoff | матовые соединения

milltek solid milltek gel

sintetici lucidi | glossy synthetics | synthétiques brilliants | glänzende Synthetische  
 Глянцевые соединения

milltek gel

due vasche | two basins | deux vasques | zwei Becken | две раковины  
 L top | W top | L plan | B Platte | Ш столешница

Round 01 + Round 01 = min 180 cm | 70 7/8"  
 Round 02 + Round 02 = min 180 cm | 70 7/8"

top | plan | Platte | столешница  
 sp. | th. | sp. | Di. | тол.

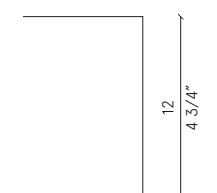



LAND 01 | LAND 02

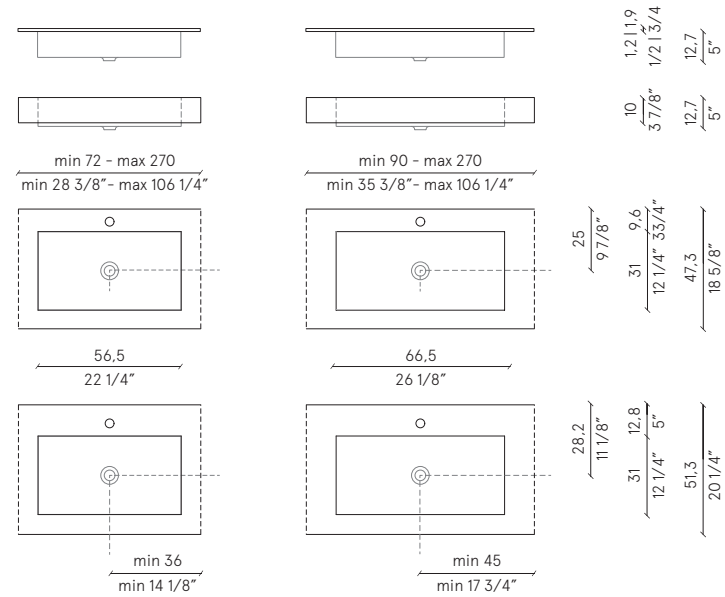

finiture | finishes | finitions | Oberflächen | отделки  
argille | clays | argiles | Lehm | глины

due vasche | two basins | deux vasques | zwei Becken | две раковины  
L top | W top | L plan | B Platte | Ш столешница

top | plan | Platte | столешница  
sp. | th. | sp. | Di. | тол.

Land 01 + Land 01 = min 144 cm | 56 3/4"  
Land 02 + Land 02 = min 180 cm | 70 7/8"

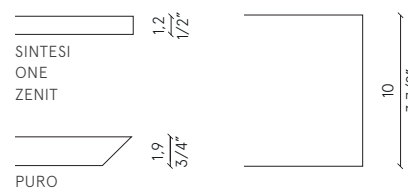

Gres Laminam - PURO escluso | except | sauf | Außer | кроме

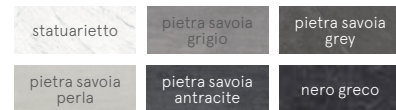

LAND 01 | LAND 02

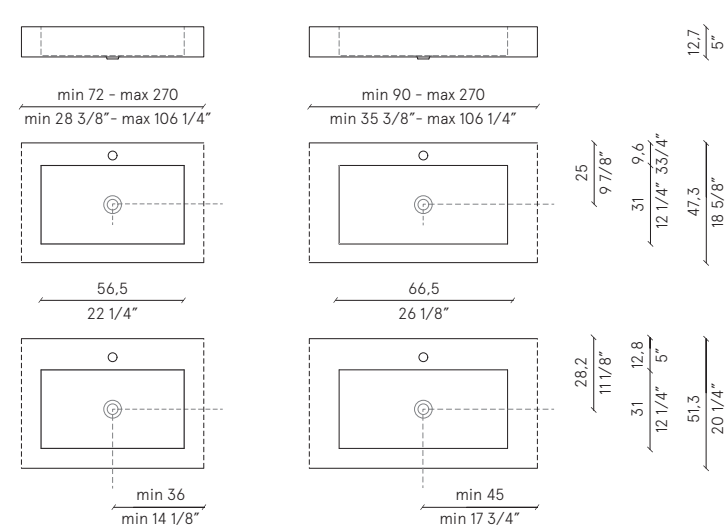

finiture | finishes | finitions | Oberflächen | отделки  
argille | clays | argiles | Lehm | глины

due vasche | two basins | deux vasques | zwei Becken | две раковины  
L top | W top | L plan | B Platte | Ш столешница

top | plan | Platte | столешница  
sp. | th. | sp. | Di. | тол.

Land 01 + Land 01 = min 144 cm | 56 3/4"  
Land 02 + Land 02 = min 180 cm | 70 7/8"

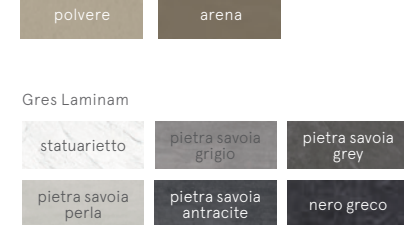

Gres Laminam

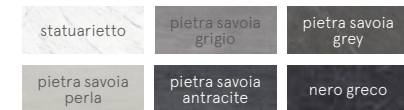





SPAN 01 | SPAN 02 | SPAN 03 | SPAN 04

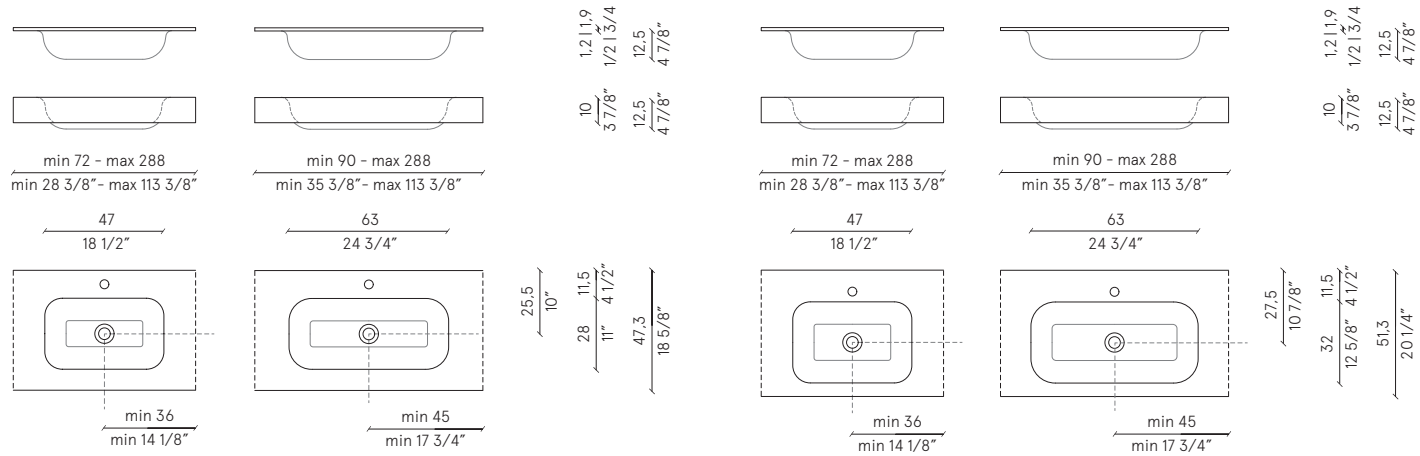

finiture | finishes | finitions | Oberflächen | отделки  
 sintetico opaco | matt synthetic | synthétique mat | Matt Synthetisch | матовое  
 соединение

corian

due vasche | two basins | deux vasques | zwei Becken | две раковины  
 L top | W top | L plan | B Platte | Ш столешница

Span 01 + Span 01 = min 144 cm | 56 3/4"  
 Span 02 + Span 02 = min 180 cm | 70 7/8"  
 Span 03 + Span 03 = min 144 cm | 56 3/4"  
 Span 04 + Span 04 = min 180 cm | 70 7/8"

top | plan | Platte | столешница  
 sp. lth. | sp. | Di. | тол.

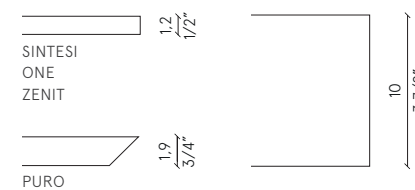

SPAN 01 | SPAN 02 | SPAN 03 | SPAN 04

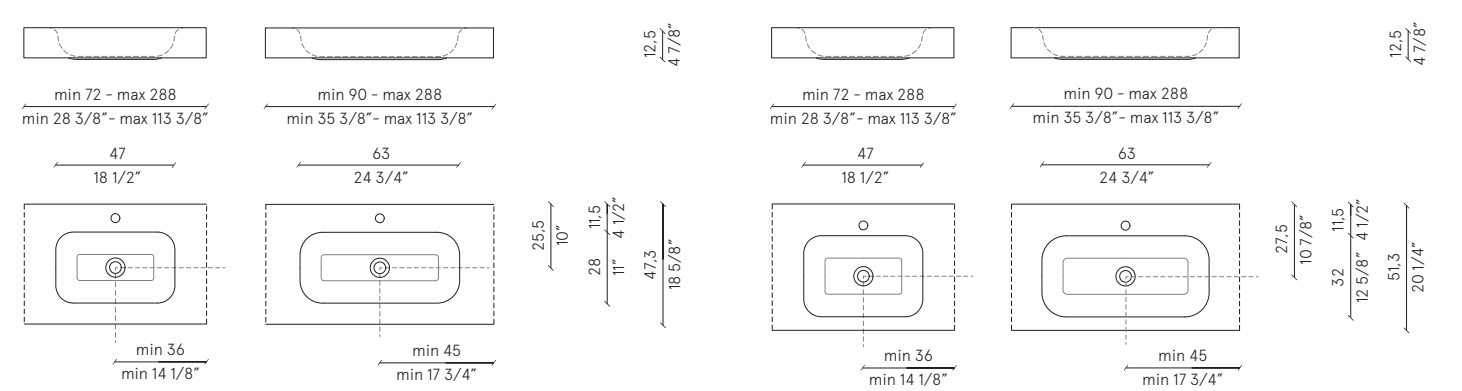

finiture | finishes | finitions | Oberflächen | отделки  
 sintetico opaco | matt synthetic | synthétique mat | Matt Synthetisch | матовое  
 соединение

corian

due vasche | two basins | deux vasques | zwei Becken | две раковины  
 L top | W top | L plan | B Platte | Ш столешница

Span 01 + Span 01 = min 144 cm | 56 3/4"  
 Span 02 + Span 02 = min 180 cm | 70 7/8"  
 Span 03 + Span 03 = min 144 cm | 56 3/4"  
 Span 04 + Span 04 = min 180 cm | 70 7/8"

top | plan | Platte | столешница  
 sp. lth. | sp. | Di. | тол.

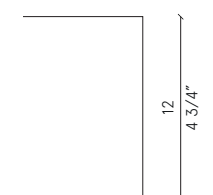



STILL 01 | STILL 02 | STILL 04

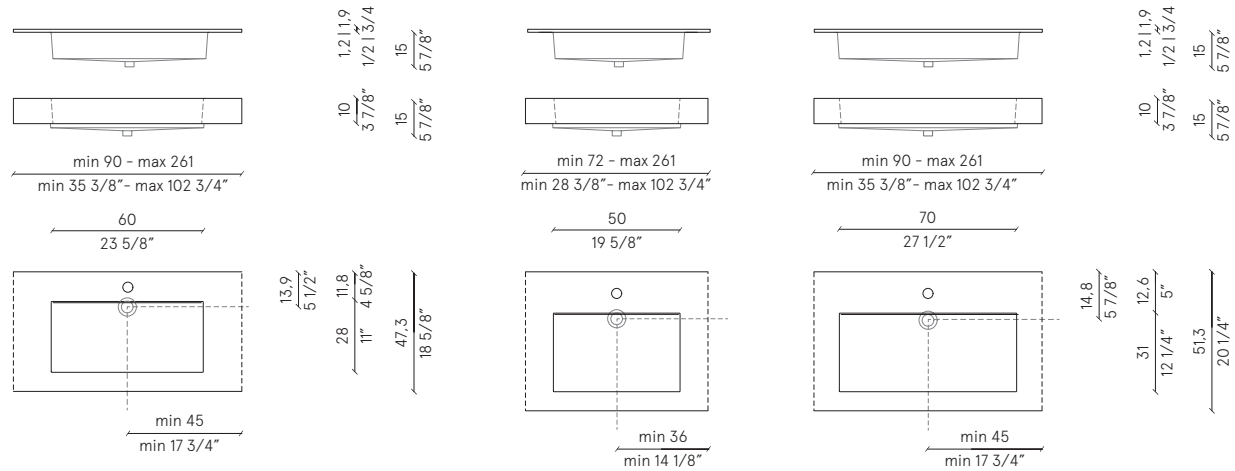

finiture | finishes | finitions | Oberflächen | отделки  
 sintetici opachi | matt compounds | synthétiques mates | Matt Kunststoff | матовые соединения

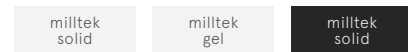

sintetici lucidi | glossy synthetics | synthétiques brilliants | glänzende Synthetische  
 Глянцевые соединения

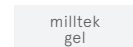

due vasche | two basins | deux vasques | zwei Becken | две раковины  
 L top | W top | L plan | B Platte | Ш столешница

Still 01 + Still 01 = min 180 cm | 70 7/8"  
 Still 02 + Still 02 = min 144 cm | 56 3/4"  
 Still 04 + Still 04 = min 180 cm | 70 7/8"

top | plan | Platte | столешница  
 sp. | th. | sp. | Di. | тол.

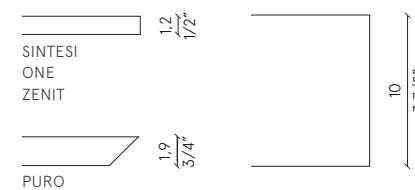

STILL 01 | STILL 02 | STILL 04

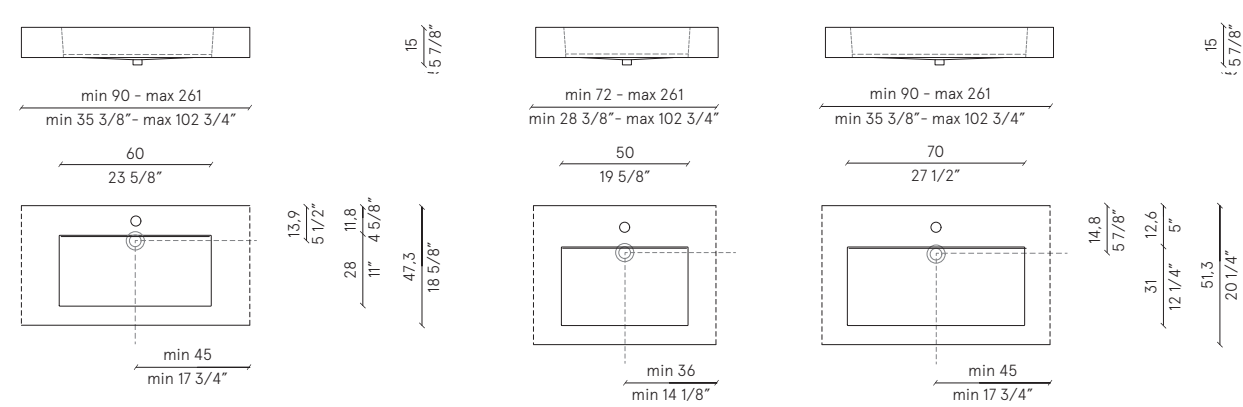

finiture | finishes | finitions | Oberflächen | отделки  
 sintetici opachi | matt compounds | synthétiques mates | Matt Kunststoff | матовые соединения

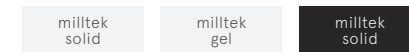

sintetici lucidi | glossy synthetics | synthétiques brilliants | glänzende Synthetische  
 Глянцевые соединения

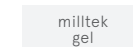

due vasche | two basins | deux vasques | zwei Becken | две раковины  
 L top | W top | L plan | B Platte | Ш столешница

Still 01 + Still 01 = min 180 cm | 70 7/8"  
 Still 02 + Still 02 = min 144 cm | 56 3/4"  
 Still 04 + Still 04 = min 180 cm | 70 7/8"

top | plan | Platte | столешница  
 sp. | th. | sp. | Di. | тол.

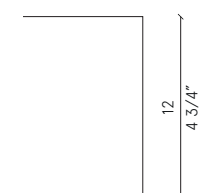





design Lino Codato

NEXT 56 | NEXT 90 | NEXT 110

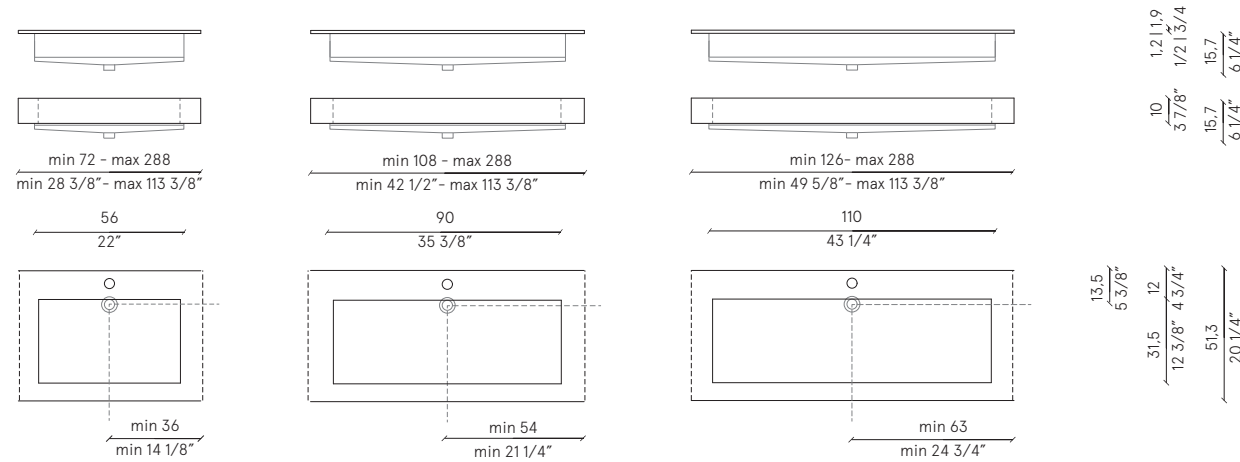

finiture | finishes | finitions | Oberflächen | отделки  
 sintetico opaco | matt synthetic | synthétique mat | Matt Synthetisch | матовый соединение

corian

marmo opaco | matt marble | marbre mat | Matt Marmor | матовый мрамор

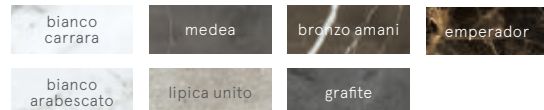

due vasche | two basins | deux vasques | zwei Becken | две раковины  
 L top | W top | L plan | B Platte | Ш столешница

Next 56 + Next 56 = min 144 cm | 56 3/4"  
 Next 90 + Next 90 = min 216 cm | 85"  
 Next 110 + Next 110 = min 252 cm | 99 1/4"

top | plan | Platte | столешница  
 sp. | th. | sp. | Di. | тол.

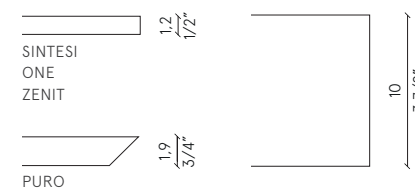

design Lino Codato

NEXT 56 | NEXT 90 | NEXT 110

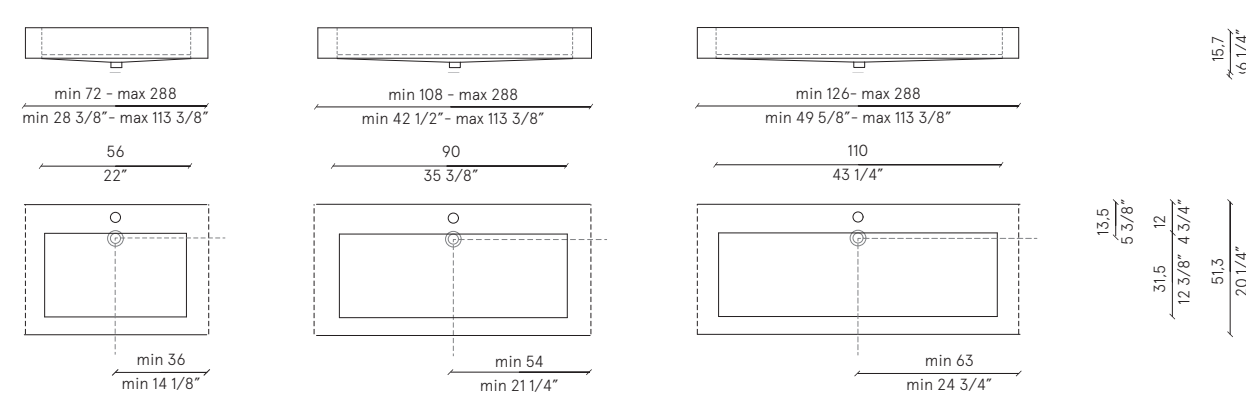

finiture | finishes | finitions | Oberflächen | отделки  
 sintetico opaco | matt synthetic | synthétique mat | Matt Synthetisch | матовый соединение

corian

marmo opaco | matt marble | marbre mat | Matt Marmor | матовый мрамор

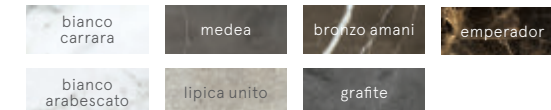

due vasche | two basins | deux vasques | zwei Becken | две раковины  
 L top | W top | L plan | B Platte | Ш столешница

Next 56 + Next 56 = min 144 cm | 56 3/4"  
 Next 90 + Next 90 = min 216 cm | 85"  
 Next 110 + Next 110 = min 252 cm | 99 1/4"

top | plan | Platte | столешница  
 sp. | th. | sp. | Di. | тол.

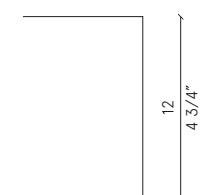



design Giuseppe Bavuso

HORIZON 50 | HORIZON 70

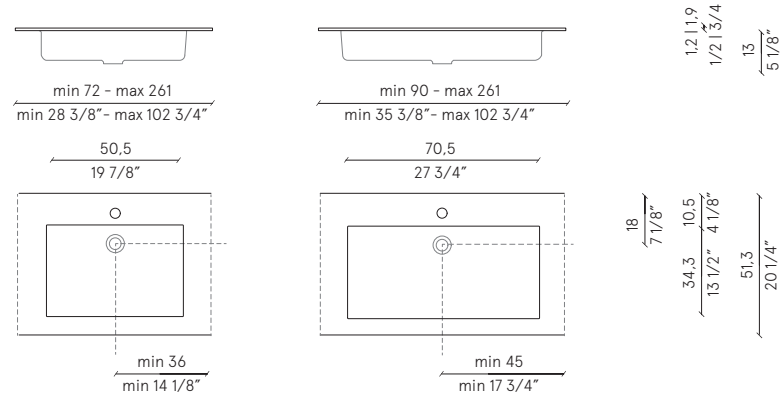

finiture | finishes | finitions | Oberflächen | отделки  
 sintetici opachi | matt compounds | synthétiques mates | Matt Kunststoff | матовые соединения



sintetici lucidi | glossy synthetics | synthétiques brilliants | glänzende Synthetische  
 Глянцевые соединения

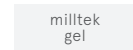

marmo opaco | matt marble | marbre mat | Matt Marmor | матовый мрамор

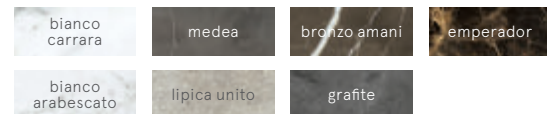

due vasche | two basins | deux vasques | zwei Becken | две раковины  
 L top | W top | L plan | B Platte | Ш столешница

Horizon 50 + Horizon 50 = min 144 cm | 56 3/4"  
 Horizon 70 + Horizon 70 = min 180 cm | 70 7/8"

top | plan | Platte | столешница  
 sp. | th. | sp. | Di. | тол.

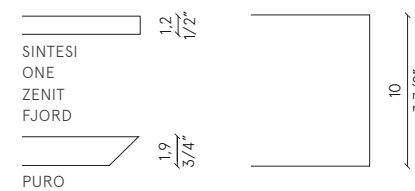

design Giuseppe Bavuso

FINN 50 | FINN 70

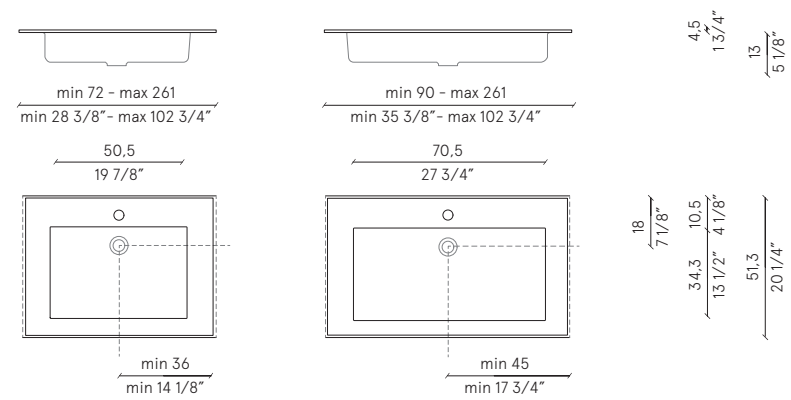

finiture | finishes | finitions | Oberflächen | отделки  
 sintetico opaco | matt synthetic | synthétique mat | Matt Synthetisch | матовое соединение

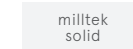

due vasche | two basins | deux vasques | zwei Becken | две раковины  
 L top | W top | L plan | B Platte | Ш столешница

Finn 50 + Finn 50 = min 144 cm | 56 3/4"  
 Finn 70 + Finn 70 = min 180 cm | 70 7/8"

top | plan | Platte | столешница  
 sp. | th. | sp. | Di. | тол.

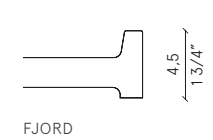





design Michele Marcon

DIP 35 | DIP 58 | DIP 94

con piano copripiletta | with drain cover | avec plan cache-bond | mit Abfluss Abdeckung | плоская крышка слива

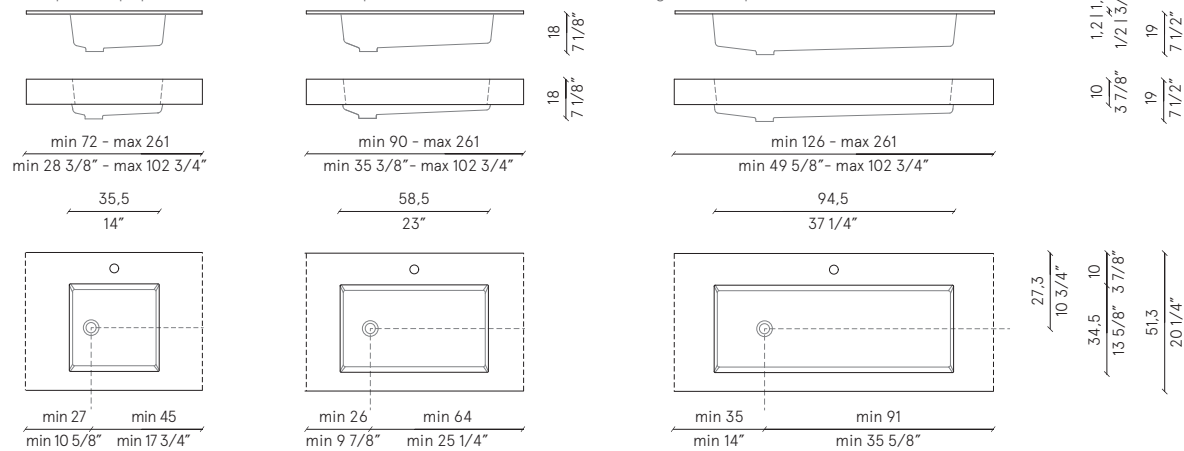

finiture | finishes | finitions | Oberflächen | отделки  
 sintetico opaco | matt synthetic | synthétique mat | Matt Synthetisch | матовое  
 соединение

milltek  
solid

due vasche | two basins | deux vasques | zwei Becken | две раковины  
 L top | W top | L plan | B Platte | Ш столешница

Dip 35 + Dip 35 = min 108 cm | 42 1/2"  
 Dip 58 + Dip 58 = min 144 cm | 56 3/4"  
 Dip 94 + Dip 94 = min 252 cm | 99 1/4"

top | plan | Platte | столешница  
 sp. | th. | sp. | Di. | тол.

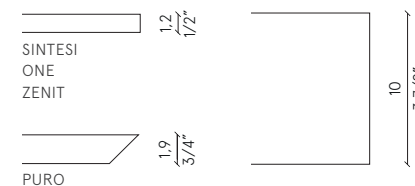

design Michele Marcon

TRAY 35 | TRAY 58 | TRAY 94

con piano copripiletta | with drain cover | avec plan cache-bond | mit Abfluss Abdeckung | плоская крышка слива

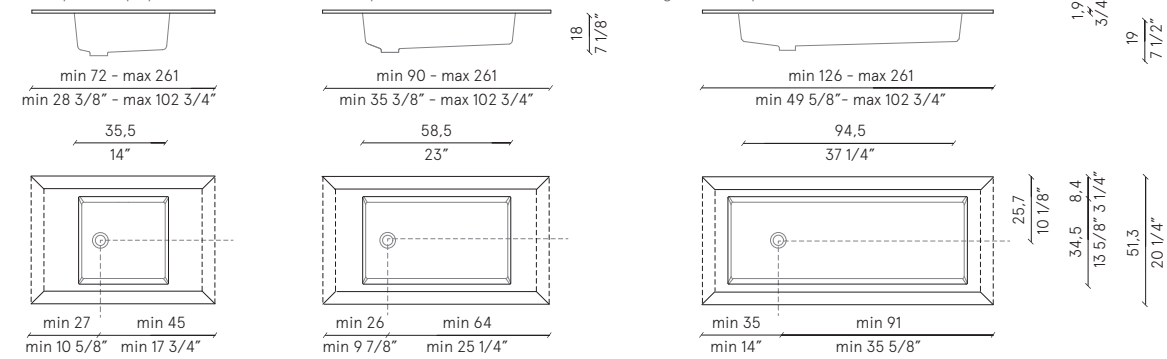

finiture | finishes | finitions | Oberflächen | отделки  
 sintetico opaco | matt synthetic | synthétique mat | Matt Synthetisch | матовое  
 соединение

milltek  
solid

due vasche | two basins | deux vasques | zwei Becken | две раковины  
 L top | W top | L plan | B Platte | Ш столешница

Tray 35 + Tray 35 = min 108 cm | 42 1/2"  
 Tray 58 + Tray 58 = min 144 cm | 56 7/8"  
 Tray 94 + Tray 94 = min 252 cm | 99 1/4"

top | plan | Platte | столешница  
 sp. | th. | sp. | Di. | тол.





design Michele Marcon

WHOLE 72 | WHOLE 90 | WHOLE 108

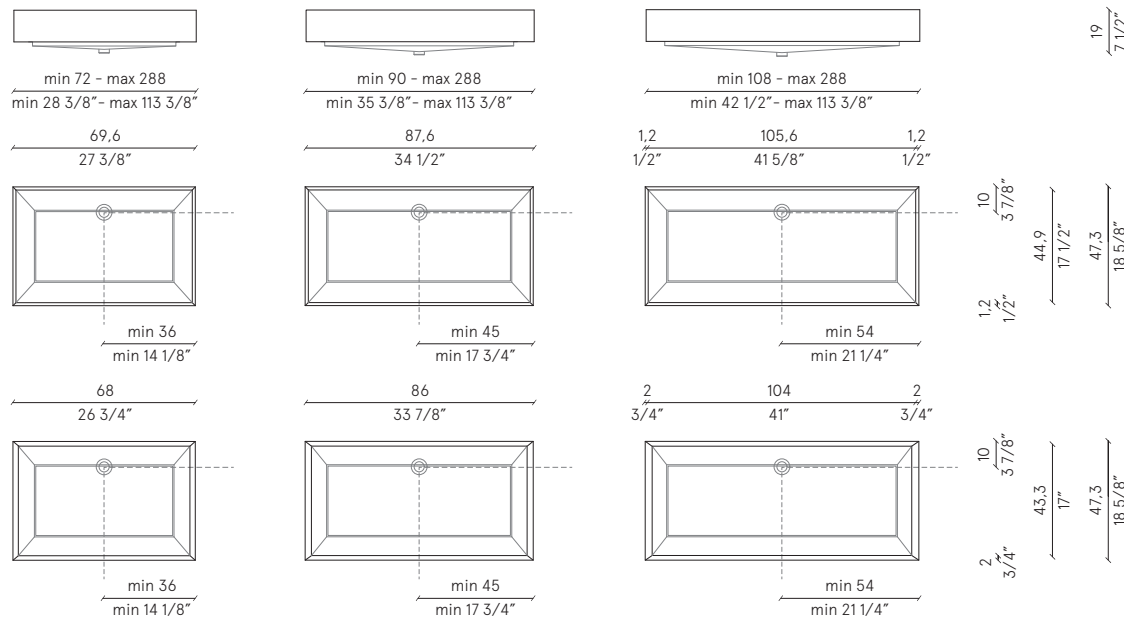

corian

marmo opachi  
matt marbles  
marbres mates  
matt Marmor  
матовые мраморы

finiture | finishes | fnitions | Oberflächen | отделки  
sintetico opaco | matt synthetic | synthétique mat | Matt Synthetisch | матовое  
соединение

corian

marmo opaco | matt marble | marbre mat | Matt Marmor | матовый мрамор

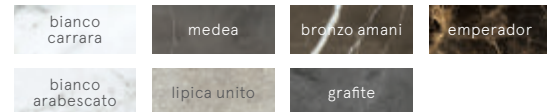

due vasche | two basins | deux vasques | zwei Becken | две раковины  
L top | W top | L plan | B Platte | Ш столешница

Whole 72 + Whole 72 = min 144 cm | 56 3/4"  
Whole 90 + Whole 90 = min 180 cm | 70 7/8"  
Whole 108 + Whole 108 = min 216 cm | 85"

top | plan | Platte | столешница  
sp. | th. | sp. | Di. | тол.

SINTESI  
ZENIT

design Michele Marcon

HEIGHT 72 | HEIGHT 90 | HEIGHT 108

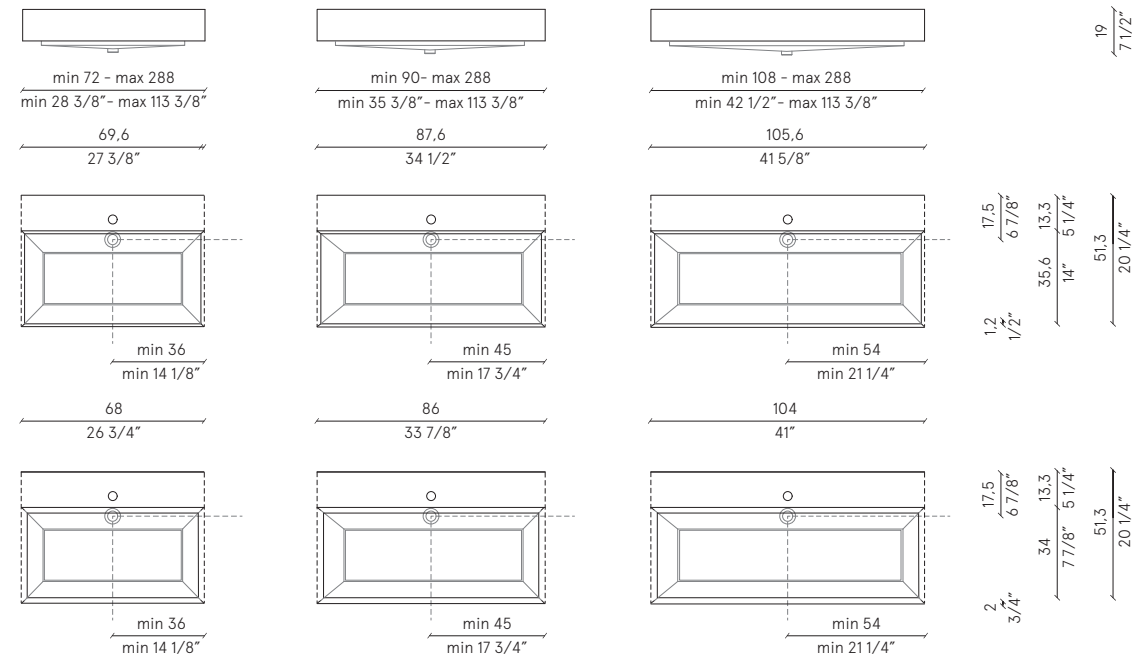

corian

marmo opachi  
matt marbles  
marbres mates  
matt Marmor  
матовые мраморы

finiture | finishes | fnitions | Oberflächen | отделки  
sintetico opaco | matt synthetic | synthétique mat | Matt Synthetisch | матовое  
соединение

corian

marmo opaco | matt marble | marbre mat | Matt Marmor | матовый мрамор

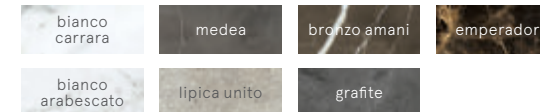

due vasche | two basins | deux vasques | zwei Becken | две раковины  
L top | W top | L plan | B Platte | Ш столешница

Height 72 + Height 72 = min 144 cm | 56 3/4"  
Height 90 + Height 90 = min 180 cm | 70 7/8"  
Height 108 + Height 108 = min 216 cm | 85"

top | plan | Platte | столешница  
sp. | th. | sp. | Di. | тол.

SINTESI  
ONE  
ZENIT

PURO





BRILLIANT g04 | BRILLIANT g05

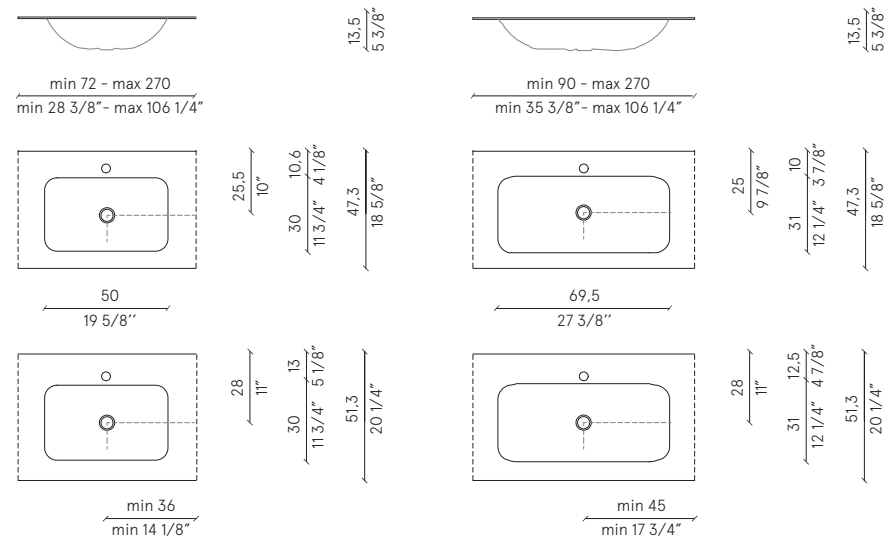

finiture | finishes | finitions | Oberflächen | отделки  
vetri | glasses | verres | Gläser | стекла

22 colours

due vasche | two basins | deux vasques | zwei Becken | две раковины  
L top | W top | L plan | B Platte | Ш столешница

Brilliant g04 + Brilliant g04 = min 144 cm | 56 7/8"  
Brilliant g05 + Brilliant g05 = min 180 cm | 70 7/8"

top | plan | Platte | столешница  
sp. | th. | sp. | Di. | тол.

SINTESI  
ONE  
ZENIT

PURO



BRILLIANT m04 | BRILLIANT m05

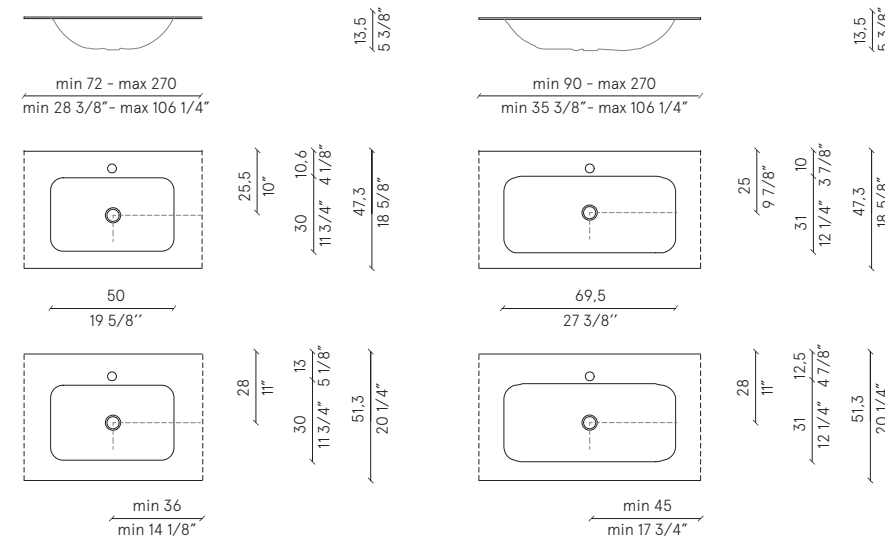

finiture | finishes | finitions | Oberflächen | отделки  
vetro satinato | satin glass | verre satiné | Milchglas | сатирированное стекло

22 colours

due vasche | two basins | deux vasques | zwei Becken | две раковины  
L top | W top | L plan | B Platte | Ш столешница

Brilliant m04 + Brilliant m04 = min 144 cm | 56 7/8"  
Brilliant m05 + Brilliant m05 = min 180 cm | 70 7/8"

top | plan | Platte | столешница  
sp. | th. | sp. | Di. | тол.

SINTESI  
ONE  
ZENIT

PURO



design Michele Marcon

STRICT 54 | STRICT 88 | STRICT 140

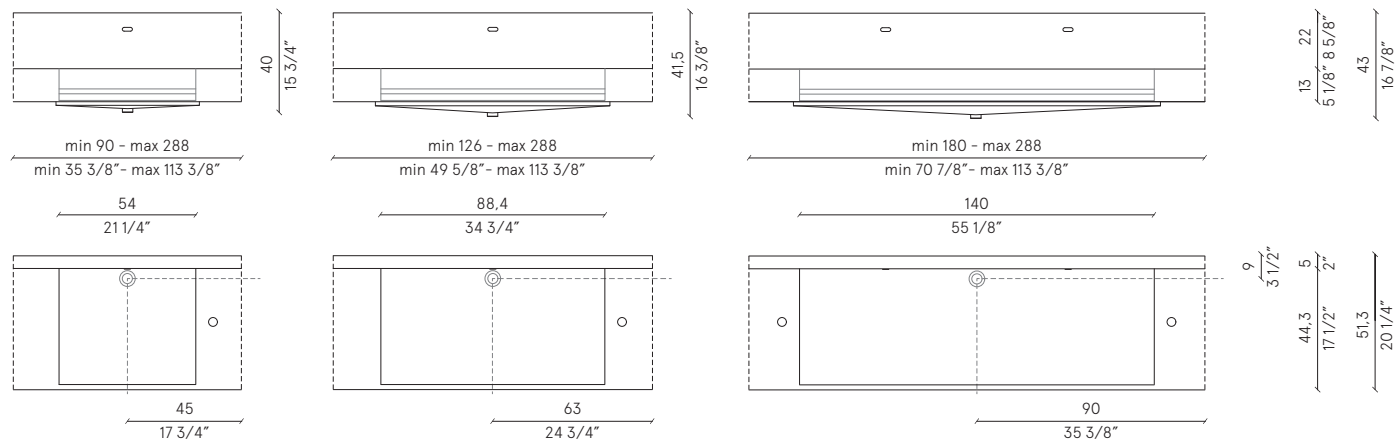

finiture | finishes | finitions | Oberflächen | отделки  
 sintetico opaco | matt synthetic | synthétique mat | Matt Synthetisch | матовое соединение

corian

marmo opaco | matt marble | marbre mat | Matt Marmor | матовый мрамор

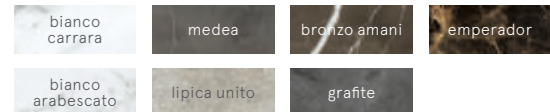

top | plan | Platte | столешница  
 sp. | th. | sp. | Di. | тол.

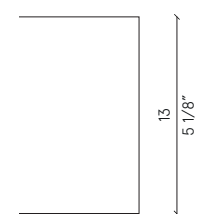

design Michele Marcon

UNIQUE 54 - 216

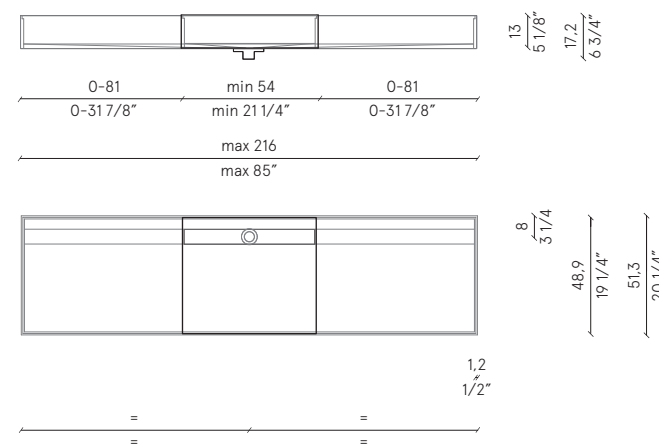

finiture | finishes | finitions | Oberflächen | отделки  
 sintetico opaco | matt synthetic | synthétique mat | Matt Synthetisch | матовое соединение

corian

top | plan | Platte | столешница  
 sp. | th. | sp. | Di. | тол.

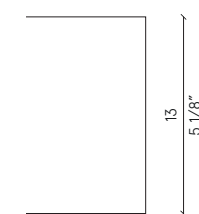



# Bathtubs and shower trays

OVAL

freestanding



OVAL

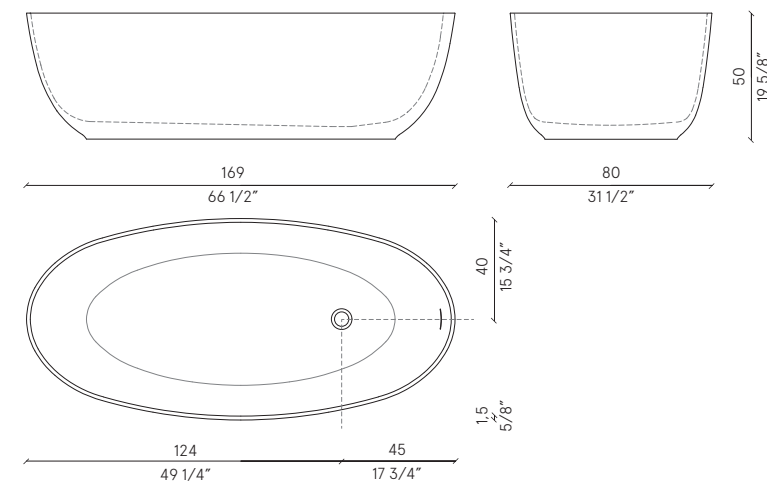

finiture | finishes | finitions | Oberflächen | отделки  
sintetico opaco | matt synthetic | synthétique mat | Matt Synthetisch | матовый соединение

cristalplant

esterno laccato opaco | Matt lacquered exterior | Extérieur laqué mat | Außenmattlack | Внешняя поверхность в матовой лакировке

22 colours



design Lievore Altherr

AZUMA 85

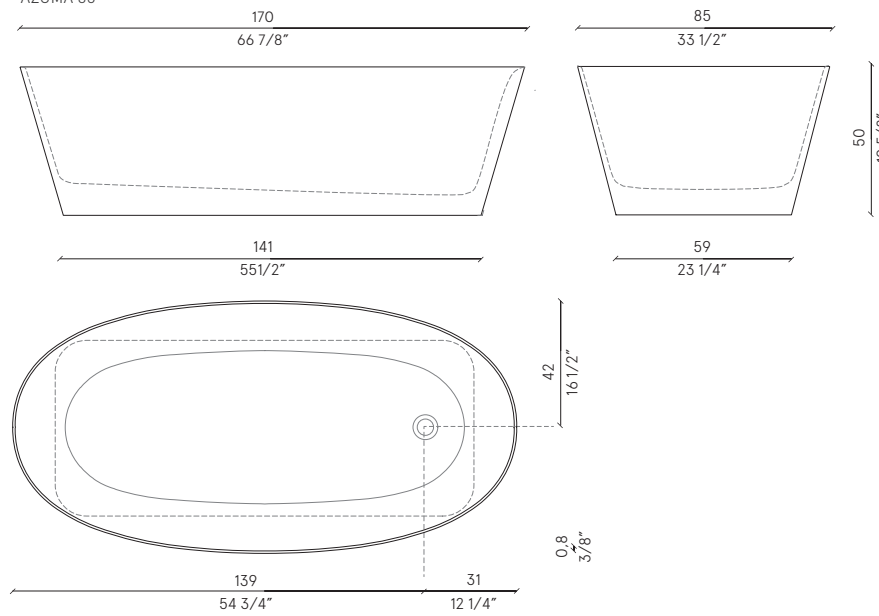

finiture | finishes | finitions | Oberflächen | отделки  
 sintetico opaco | matt synthetic | synthétique mat | Matt Synthetisch | матовое соединение

cristalplant

esterno laccato opaco | Matt lacquered exterior | Extérieur laqué mat | Außenmattlack | Внешняя поверхность в матовой лакировке

22 colours



design Lievore Altherr

AZUMA 97

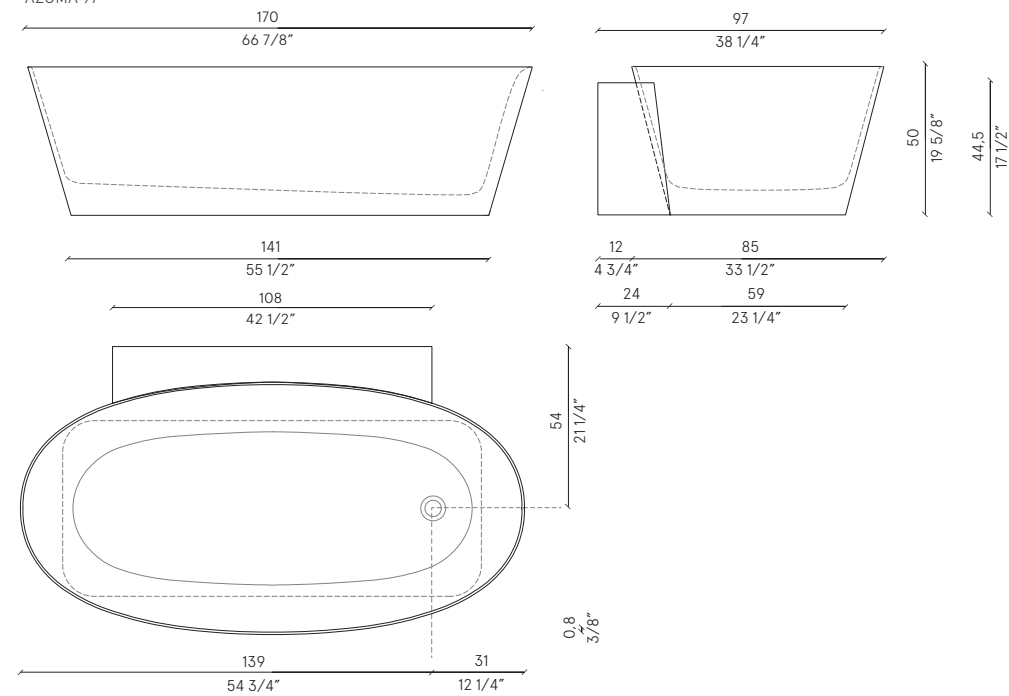

finiture | finishes | finitions | Oberflächen | отделки  
 sintetico opaco | matt synthetic | synthétique mat | Matt Synthetisch | матовое соединение

cristalplant

esterno laccato opaco | Matt lacquered exterior | Extérieur laqué mat | Außenmattlack | Внешняя поверхность в матовой лакировке

22 colours





design Michele Marcon

BRICK

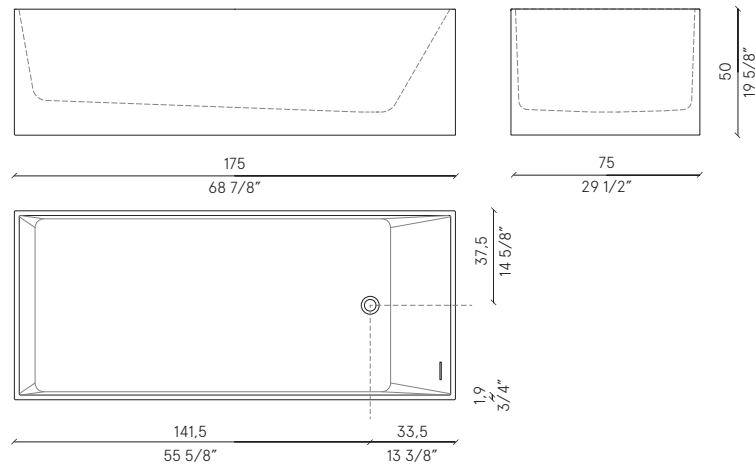

finiture | finishes | finitions | Oberflächen | отделки  
 sintetico opaco | matt synthetic | synthétique mat | Matt Synthetisch | матовое соединение

milltek  
solid



design Michele Marcon

SLASH

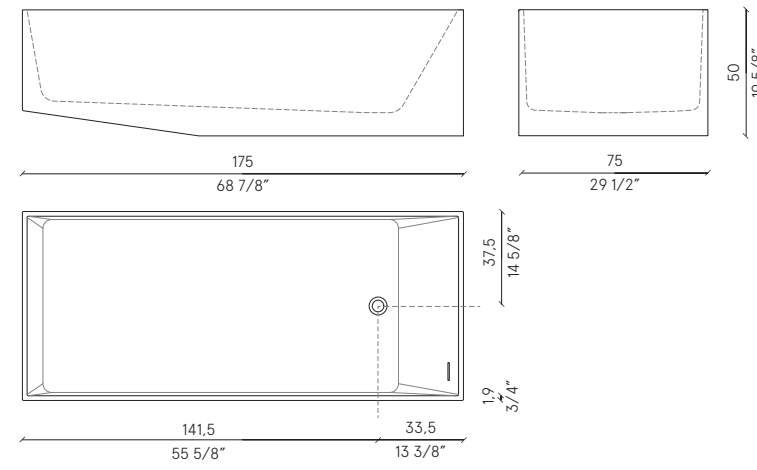

finiture | finishes | finitions | Oberflächen | отделки  
 sintetico opaco | matt synthetic | synthétique mat | Matt Synthetisch | матовое соединение

milltek  
solid



design Lino Codato

SKA 50

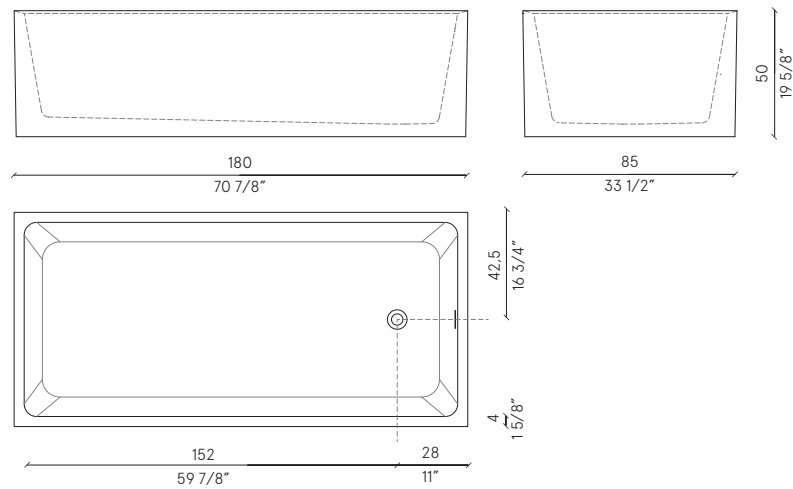

finiture | finishes | finitions | Oberflächen | отделки  
 sintético opaco | matt synthetic | synthétique mat | Matt Synthetisch | матовое соединение

milltek  
solid



design Lino Codato

SKA 35

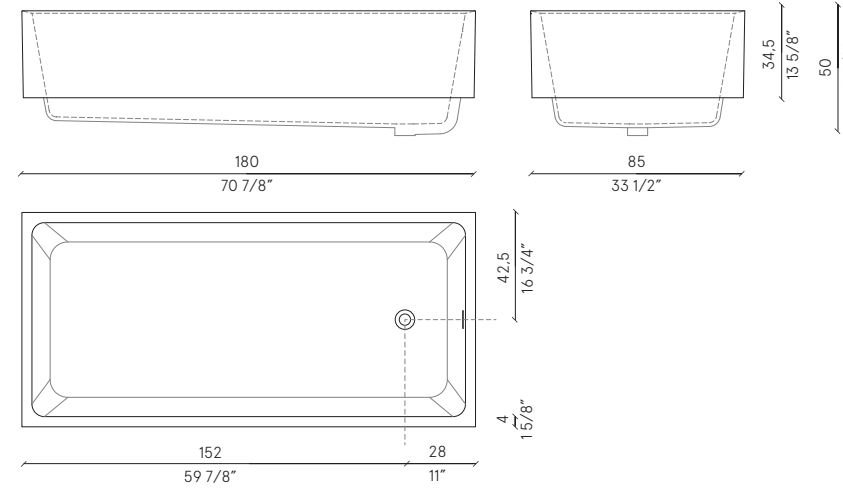

finiture | finishes | finitions | Oberflächen | отделки  
 sintético opaco | matt synthetic | synthétique mat | Matt Synthetisch | матовое соединение

milltek  
solid





STYLING R01

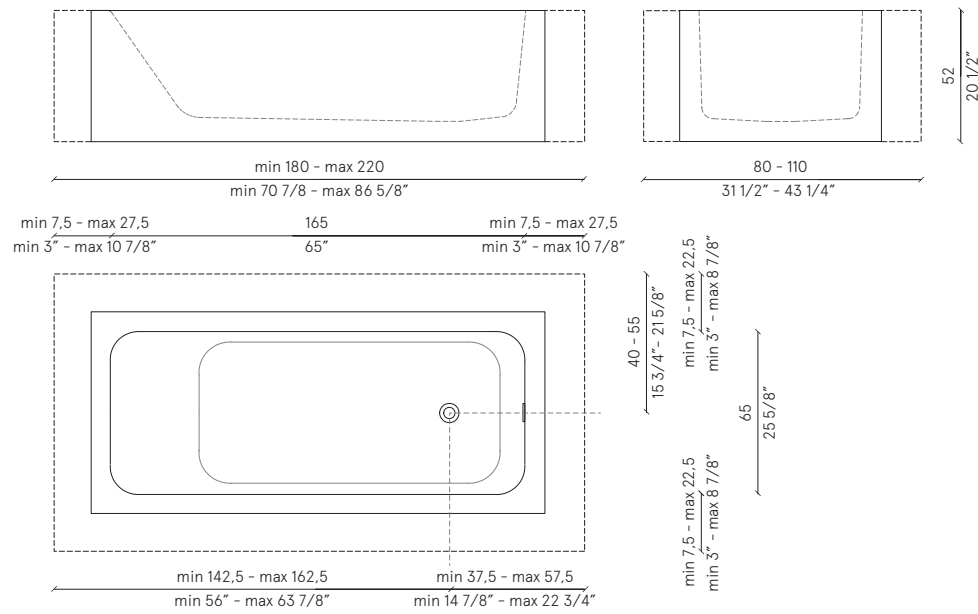

finiture | finishes | finitions | Oberflächen | отделки  
 sintético opaco | matt synthetic | synthétique mat | Matt Synthetisch | матовое соединение

crystalplant



STYLING E01

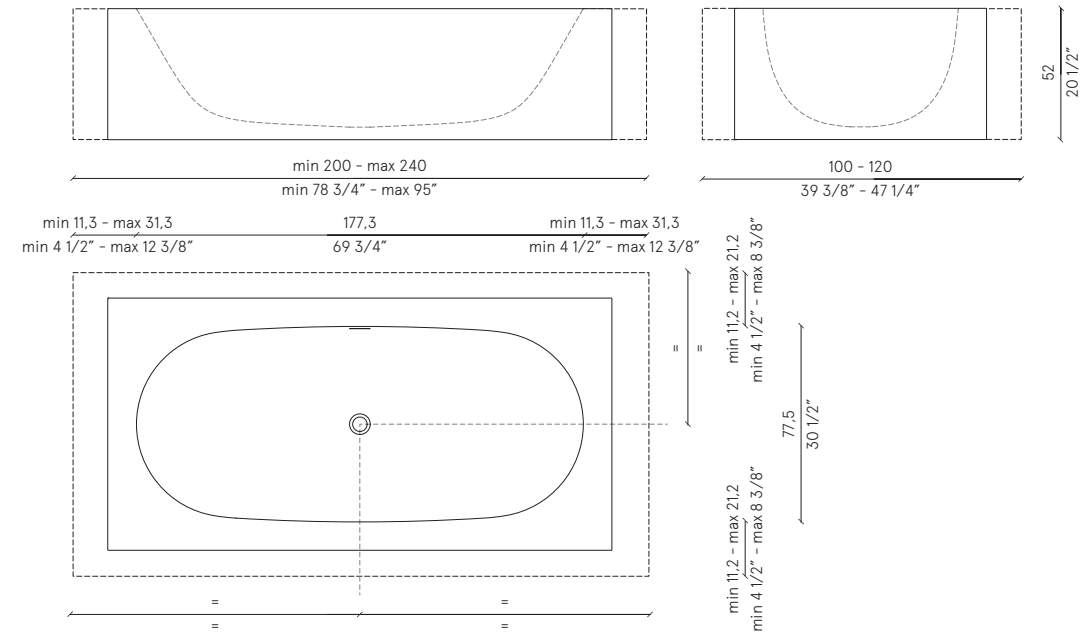

finiture | finishes | finitions | Oberflächen | отделки  
 sintético opaco | matt synthetic | synthétique mat | Matt Synthetisch | матовое соединение

crystalplant



design Lievore Altherr

ROMA

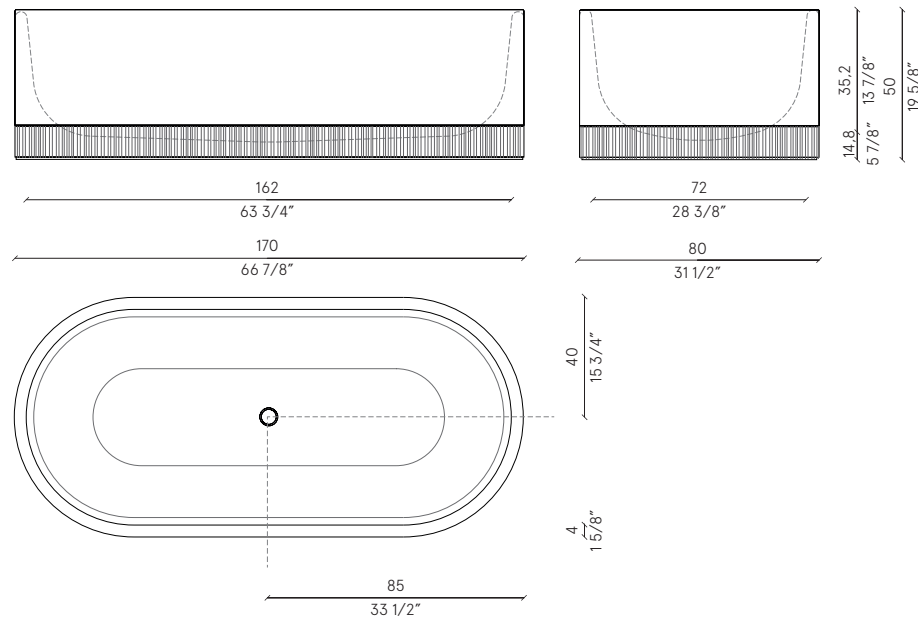

finiture | finishes | finitions | Oberflächen | отделки  
 marmo opaco | matt marble | marbre mat | Matt Marmor | матовый мрамор



combinazioni | combinations | combinaisons | Kombinationen | комбинации

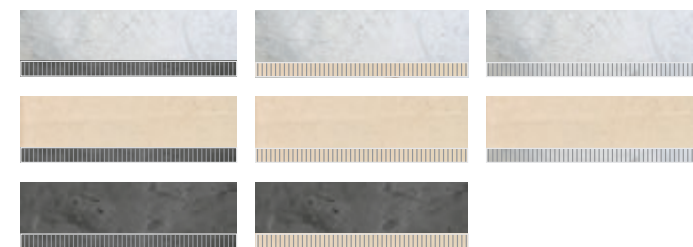

design Lino Codato

LINE H7

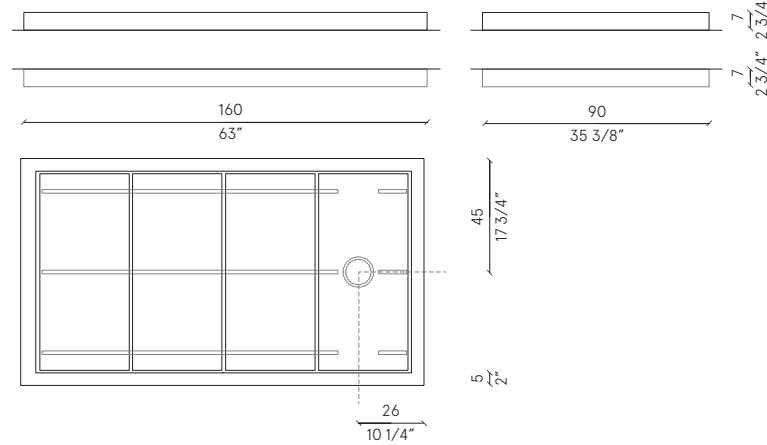

modularità | modularity | modularité | Modularität | модульность  
 su misura | customised | sur mesure | Maßgearbeitet | фиксированная мера

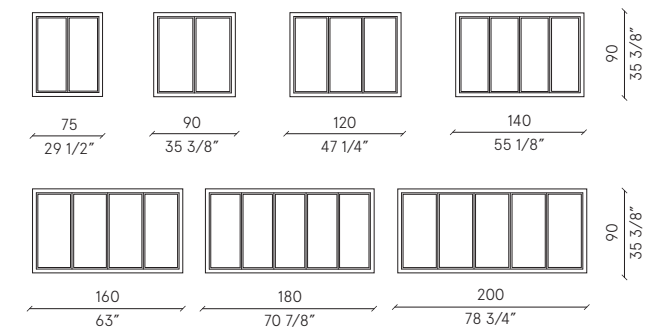

finiture | finishes | finitions | Oberflächen | отделки  
 sintetico opaco | matt synthetic | synthétique mat | Matt Synthetisch | матовый соединение

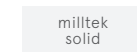





SHARP H3

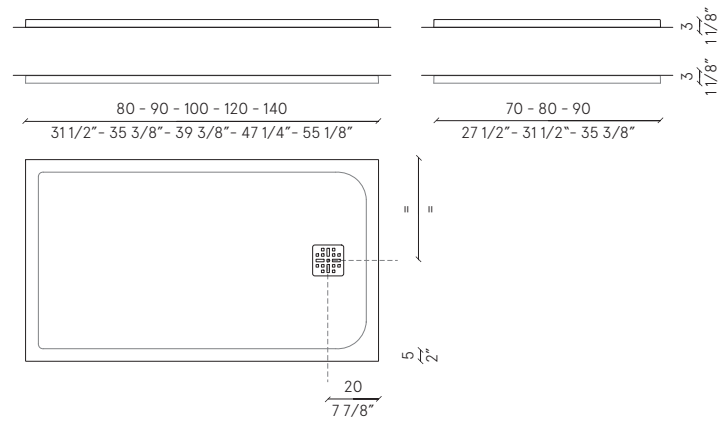

modularità | modularity | modularité | Modularität | модульность  
su misura | customised | sur mesure | Maßgearbeitet | фиксированная мера

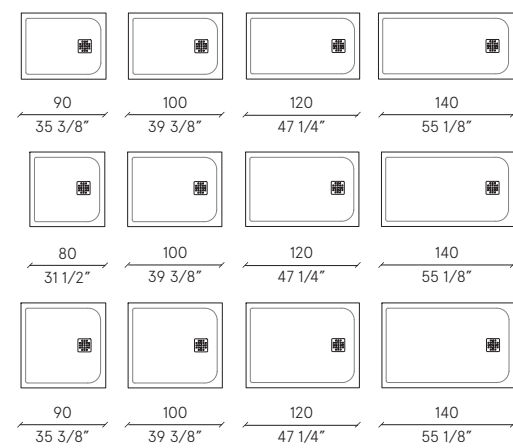

finiture | finishes | finitions | Oberflächen | отделки  
sintetici opachi | matt compounds | synthétiques mates | Matt Kunststoff | матовое соединение



SHARP H3

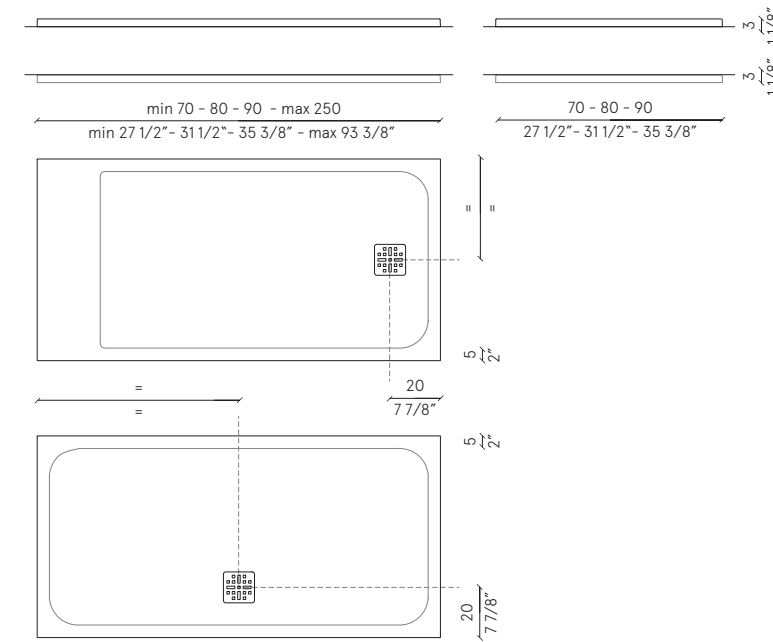

modularità | modularity | modularité | Modularität | модульность  
su misura | customised | sur mesure | Maßgearbeitet | фиксированная мера

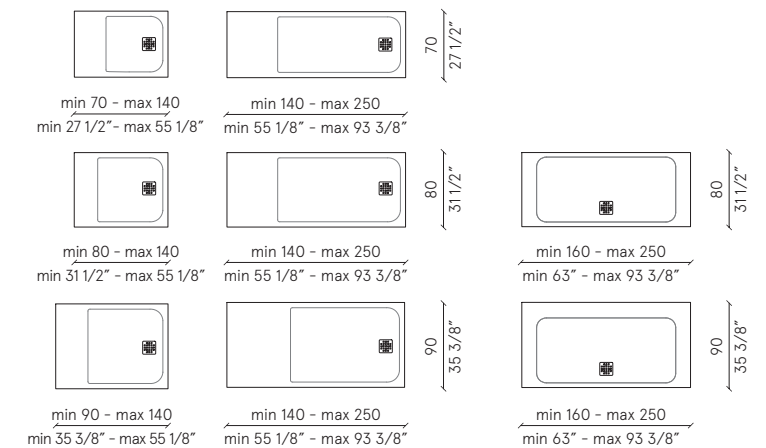

finiture | finishes | finitions | Oberflächen | отделки  
sintetici opachi | matt compounds | synthétiques mates | Matt Kunststoff | матовое соединение



FLOW L01



FLOW L01  
a parete, lavabo, cartuccia tradizionale | wall-mounted, washbasin, traditional cartridge | au mur, vasque, cartouche traditionnelle | an der Wand, Waschbecken, Standardkartusche | настенная, раковина, традиционные катриджи

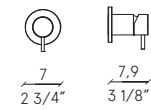
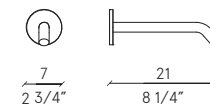

finiture | finishes | finitions | Oberflächen | отделки  
metallo | metal | métal | Metall | металл



FLOW L02

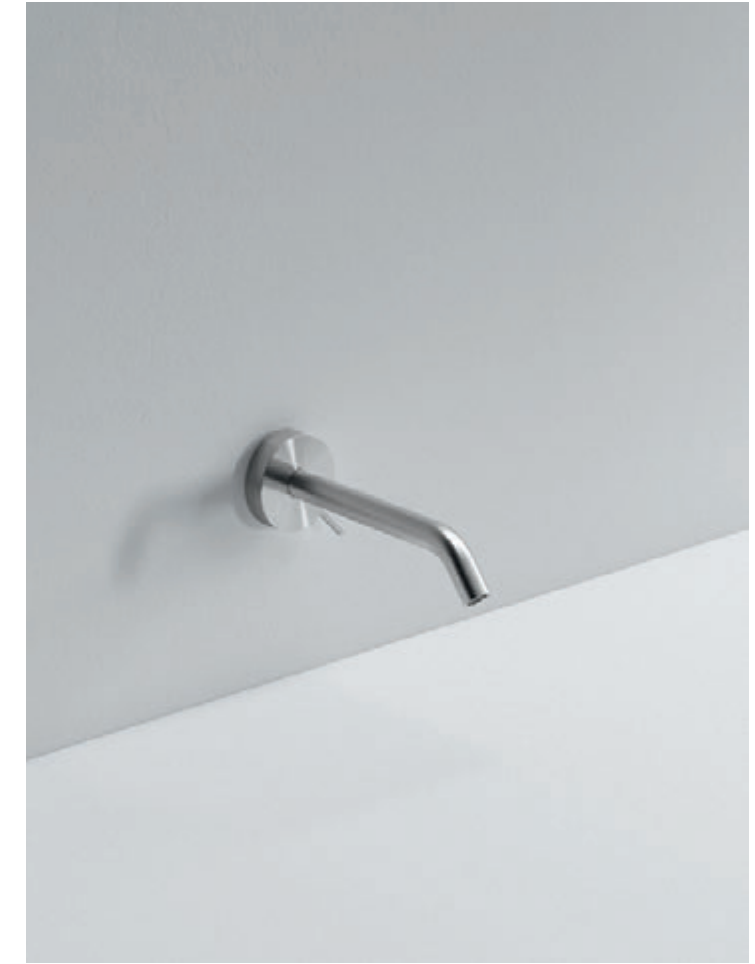

FLOW L02  
a parete, lavabo, cartucce progressive | wall-mounted, washbasin, progressive cartridge | au mur, vasque, cartouche progressive | an der Wand, Waschbecken, Progressive Kartusche | настенная, раковина, прогрессивные катриджи

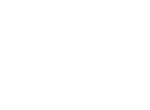
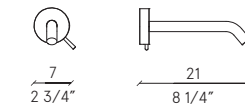

finiture | finishes | finitions | Oberflächen | отделки  
metallo | metal | métal | Metall | металл





FLOW L03



FLOW L03  
da piano, lavabo, cartuccia tradizionale | top-mounted, washbasin, traditional cartridge | sur plan, vasque, cartouche traditionnelle | flächenbündig, Waschbecken, Standardkartusche | накладная, раковина, традиционные катриджи

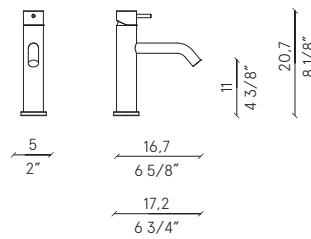

finiture | finishes | finitions | Oberflächen | отделки  
metallo | metal | métal | Metall | металл



FLOW L04



FLOW L04  
da piano, lavabo, cartuccia tradizionale | top-mounted, washbasin, traditional cartridge | sur plan, vasque, cartouche traditionnelle | flächenbündig, Waschbecken, Standardkartusche | накладная, раковина, традиционные катриджи

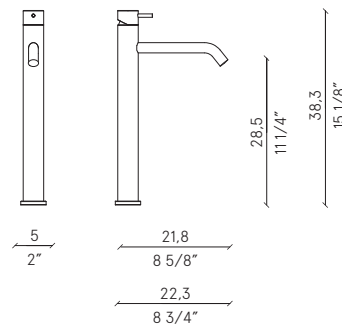

finiture | finishes | finitions | Oberflächen | отделки  
metallo | metal | métal | Metall | металл



FLOW L05



FLOW L05  
a pavimento, lavabo, cartuccia tradizionale | floor-mounted, washbasin, traditional cartridge | au sol, vasque, cartouche traditionnelle | am Fußboden, Waschbecken, Standardkartusche | напольная, раковина, традиционные катриджи

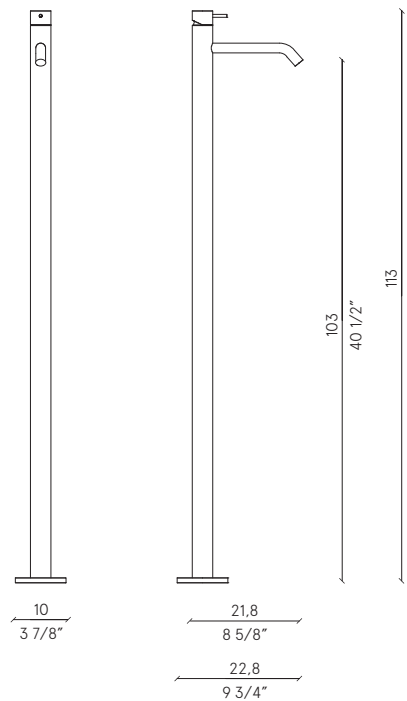

finiture | finishes | finitions | Oberflächen | отделки  
metallo | metal | métal | Metall | металл



FLOW L06



FLOW L06  
a pavimento, lavabo, cartuccia tradizionale | floor-mounted, washbasin, traditional cartridge | au sol, vasque, cartouche traditionnelle | am Fußboden, Waschbecken, Standardkartusche | напольная, раковина, традиционные катриджи

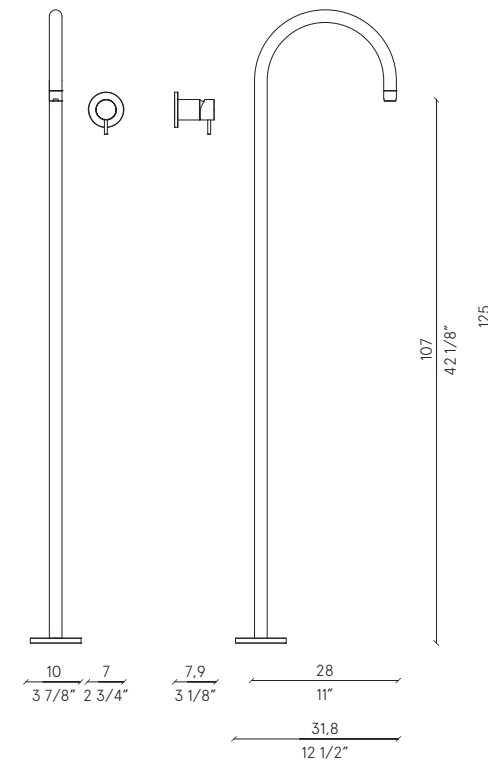

finiture | finishes | finitions | Oberflächen | отделки  
metallo | metal | métal | Metall | металл





FLOW L07 | L08  
da piano, lavabo, cartuccia tradizionale | top-mounted, washbasin, traditional cartridge  
sur plan, vasque, cartouche traditionnelle | flächenbündig, Waschbecken, Standardkartusche  
накладная, раковина, традиционные катриджи

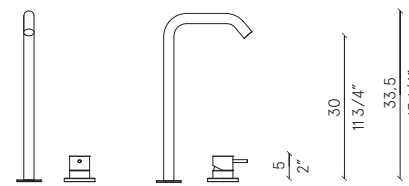
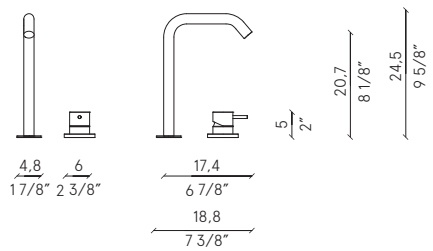

fniture | finishes | finitions | Oberflächen | отделки  
metallo | metal | métal | Metall | металл



FLOW L09 | L10  
da piano, lavabo, cartucce progressive | top-mounted, washbasin, progressive cartridge  
sur plan, vasque, cartouche progressive | flächenbündig, Waschbecken, Progressive kartusche  
накладная, раковина, прогрессивные катриджи

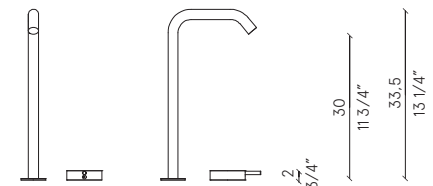
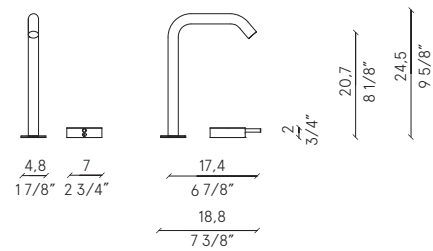

fniture | finishes | finitions | Oberflächen | отделки  
metallo | metal | métal | Metall | металл



FLOW L11 | L12  
da piano, lavabo, cartuccia tradizionale | top-mounted, washbasin, traditional cartridge  
sur plan, vasque, cartouche traditionnelle | flächenbündig, Waschbecken, Standardkartusche  
накладная, раковина, традиционные катриджи

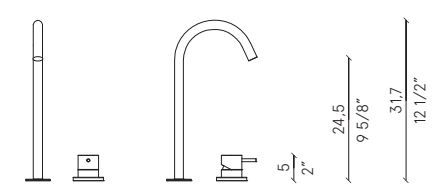
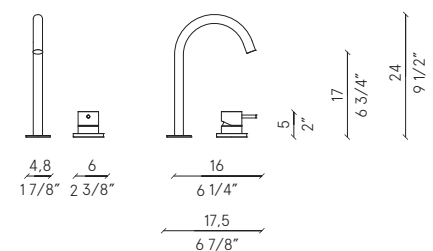

fniture | finishes | finitions | Oberflächen | отделки  
metallo | metal | métal | Metall | металл



FLOW L13 | L14  
da piano, lavabo, cartucce progressive | top-mounted, washbasin, progressive cartridge  
sur plan, vasque, cartouche progressive | flächenbündig, Waschbecken, Progressive kartusche  
накладная, раковина, прогрессивные катриджи

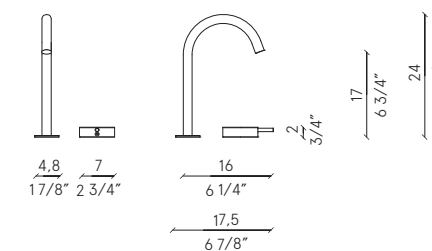

fniture | finishes | finitions | Oberflächen | отделки  
metallo | metal | métal | Metall | металл





FLOW V01



FLOW V01  
a pavimento, vasca, cartuccia tradizionale | floor-mounted, bathtub, traditional cartridge | au sol, baignoire, cartouche traditionnelle | am Fußboden, Wanne, Standardkartusche | напольная, ванна, традиционные картриджи

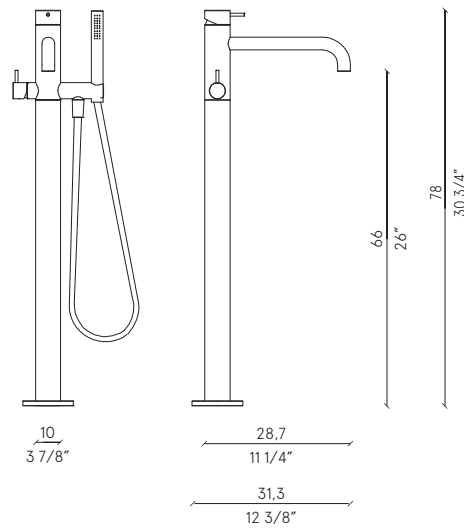

finiture | finishes | finitions | Oberflächen | отделки  
metallo | metal | métal | Metall | металл



FLOW V02



FLOW V02  
a pavimento, vasca, cartuccia tradizionale | floor-mounted, bathtub, traditional cartridge | au sol, baignoire, cartouche traditionnelle | am Fußboden, Wanne, Standardkartusche | напольная, ванна, традиционные картриджи

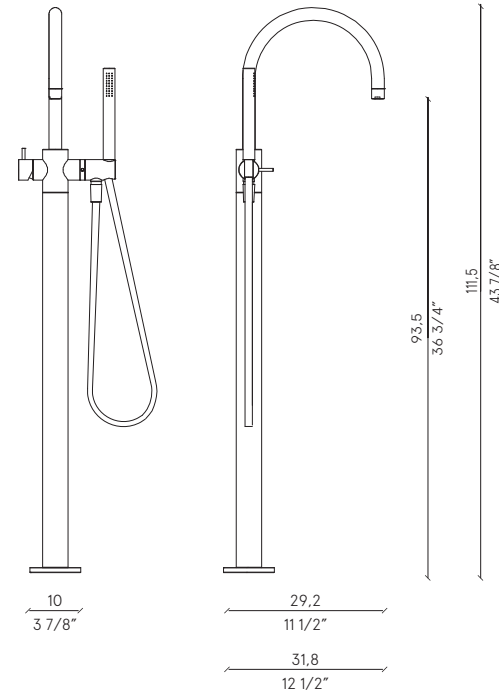

finiture | finishes | finitions | Oberflächen | отделки  
metallo | metal | métal | Metall | металл



FLOW V03



FLOW V03  
bordo vasca, cartuccia tradizionale | bathtub edge, traditional cartridge | bord baignoire, cartouche traditionnelle | Wannenrand, Standardkartusche | борт ванны, традиционные картриджи

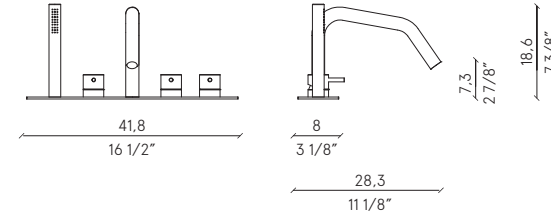

finiture | finishes | finitions | Oberflächen | отделки  
metallo | metal | métal | Metall | металл



FLOW D01



FLOW D01  
a parete, doccia | wall-mounted, shower | au mur, douche | an der Wand, Dusche | настенный, душ

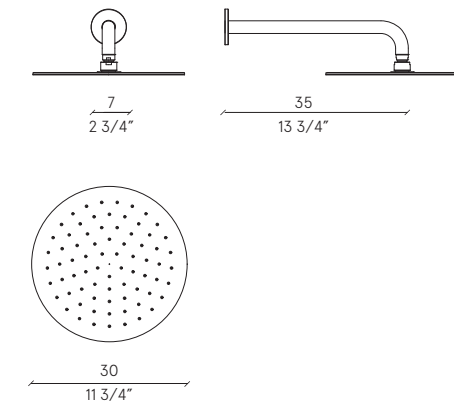

finiture | finishes | finitions | Oberflächen | отделки  
metallo | metal | métal | Metall | металл



FLOW D02



FLOW D02  
 miscelatore a parete, doccia, cartuccia tradizionale | wall-mounted mixer, shower, traditional cartridge | au mur mitigeur, douche, cartouche traditionnelle | an der Wand Mischaggregat, Dusche, Standardkartusche | настенный смеситель, душ, традиционные картриджи

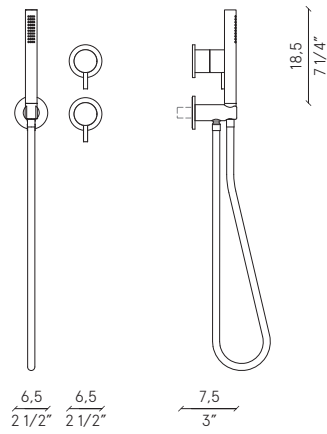

fniture | finishes | finitions | Oberflächen | отделки  
 metallo | metal | métal | Metall | металл

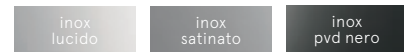

FLOW D03



FLOW D03  
 termostatico a parete, doccia, cartuccia tradizionale | thermostatic wall-mounted, shower, traditional cartridge | au mur thermostatique, douche, cartouche traditionnelle | an der Wand Thermostat, Dusche, Standardkartusche | настенный термостат, душ, традиционные картриджи

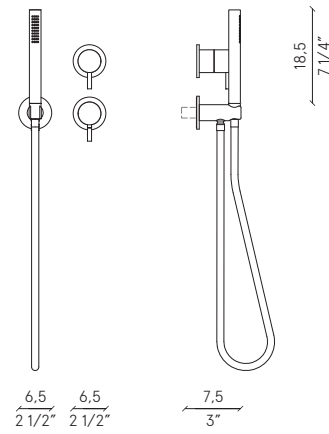

fniture | finishes | finitions | Oberflächen | отделки  
 metallo | metal | métal | Metall | металл

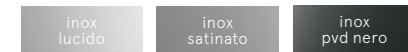

FLOW D04



FLOW D04  
 miscelatore a parete, doccia, cartucce progressive | wall-mounted mixer, shower, progressive cartridge | au mur mitigeur, douche, cartouche progressive | an der Wand Mischaggregat, Dusche, Progressive kartusche | настенный смеситель, душ, прогрессивные картриджи

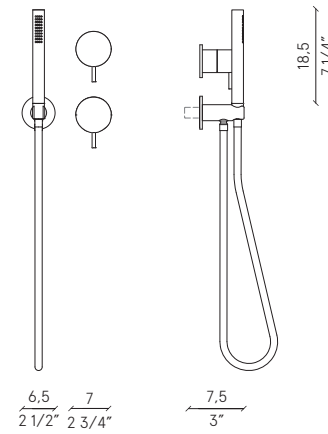

fniture | finishes | finitions | Oberflächen | отделки  
 metallo | metal | métal | Metall | металл

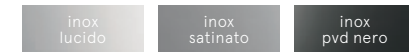

FLOW D05



FLOW D05  
 termostatico a parete, doccia, cartucce progressive | thermostatic wall-mounted, shower, progressive cartridge | au mur thermostatique, douche, cartouche progressive | an der Wand Thermostat, Dusche, Progressive kartusche | настенный термостат, душ, прогрессивные картриджи

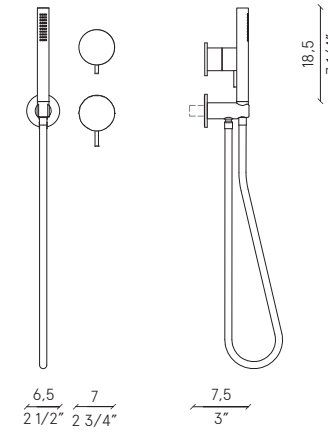

fniture | finishes | finitions | Oberflächen | отделки  
 metallo | metal | métal | Metall | металл

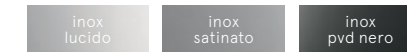





FLOW B01  
da piano, bidet, cartuccia tradizionale | top mounted, bidet, traditional cartridge | sur plan, bidet, cartouche traditionnelle | auf Platte montiert, Bidet, Standardkartusche | накладный, биде, традиционные картридж

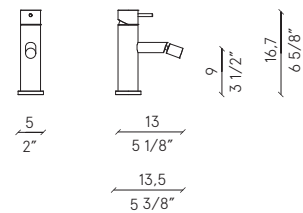

fniture | finishes | fnitions | Oberflächen | отделки  
metallo | metal | métal | Metall | металл



FLOW B02  
da piano, bidet, cartucce progressive | top mounted, bidet progressive cartridge | sur plan bidet, cartouche progressive | auf Platte montiert, Bidet, Progressive kartusche | накладный, биде, прогрессивные картриджи

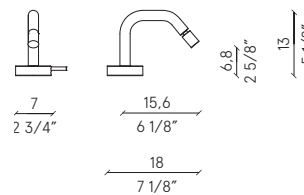

fniture | finishes | fnitions | Oberflächen | отделки  
metallo | metal | métal | Metall | металл



FLOW W01  
placca WC | toilet plate | plaque toilette | WC-Plakette | панель слива WC

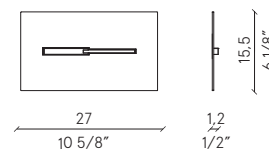

fniture | finishes | fnitions | Oberflächen | отделки  
metallo | metal | métal | Metall | металл



H20  
incasso, lavabo | inset, washbasin | encastrée, vasque | eingebaut, Waschbecken | встраиваемая, раковина

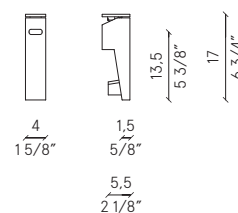

solo per: top Dip e Tray, lavabi Full e Short della collezione Touch | only with: tops mod. Dip and Tray, Touch collection washbasins mod. Full and Short | compatible seulement avec : les plans mod. Dip et Tray, les vasques de la collection Touch mod. Full et Short | Nur fuer: Platte Dip und Tray, Becken Full und Short der Kollektion Touch | совместимый только с: интегрированными столешницами мод. Dip Tray раковинами коллекции Touch мод. Full и Short

fniture | finishes | fnitions | Oberflächen | отделки  
metallo | metal | métal | Metall | металл



SENNA



SENNA BIDET

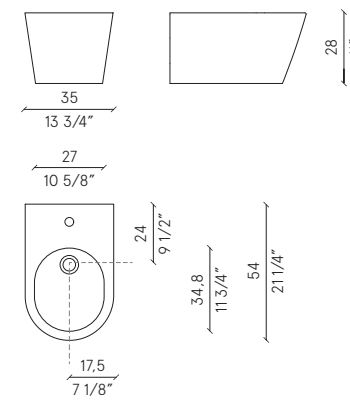

finiture | finishes | finitions | Oberflächen | отделки  
 ceramica opaca e lucida | matt and glossy ceramic | céramique mate et brillante | Mattkeramik und glänzende Keramik | матовая керамика и глянцевая керамика

bianco

SENNA



SENNA WC

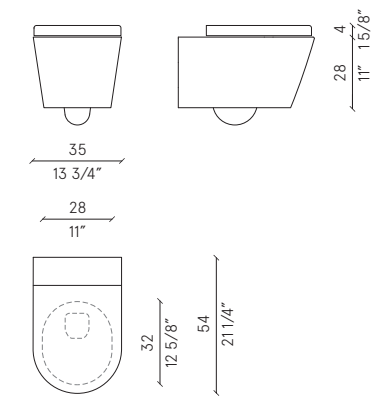

finiture | finishes | finitions | Oberflächen | отделки  
 ceramica opaca e lucida | matt and glossy ceramic | céramique mate et brillante | Mattkeramik und glänzende Keramik | матовая керамика и глянцевая керамика

bianco





VETRA

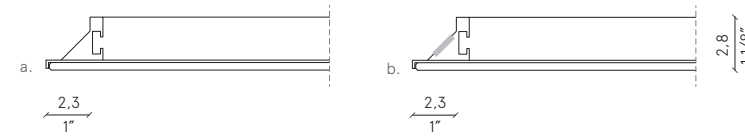

a. senza led | without led | sans led | mit LED | без светодиодов  
 b. con led | with led | avec led | ohne LED | со светодиодом

modularità | modularity | modularité | Modularität | модульность

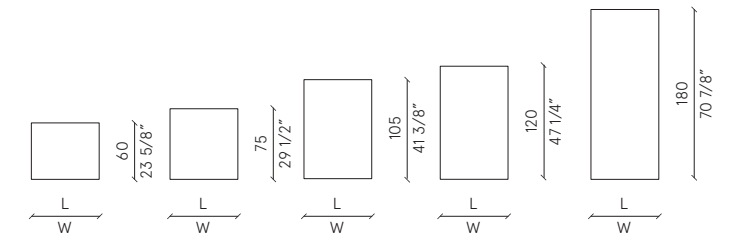

finiture | finishes | finitions | Oberflächen | отделки  
 alluminio anodizzato zero chimico | zero chemical anodised aluminium | aluminium anodisé zéro produit chimique | kein chemisch eloxiertes Aluminium | анодированный алюминий "химический ноль"

alluminio  
 anodizzato

LINEA H



LINEA H modularità | modularity | modularité | Modularität | модульность

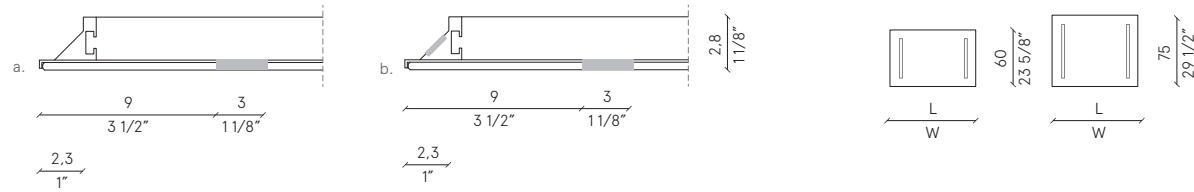

a. senza led | without led | sans led | mit LED | без светодиодов  
 b. con led | with led | avec led | ohne LED | со светодиодам

finiture | finishes | finitions | Oberflächen | отделки  
 alluminio anodizzato zero chimico | zero chemical anodised aluminum | aluminium anodisé zéro produit chimique | kein chemisch eloxiertes Aluminium | анодированный алюминий "химический ноль"

alluminio  
anodizzato

LINEA V



LINEA V modularità | modularity | modularité | Modularität | модульность

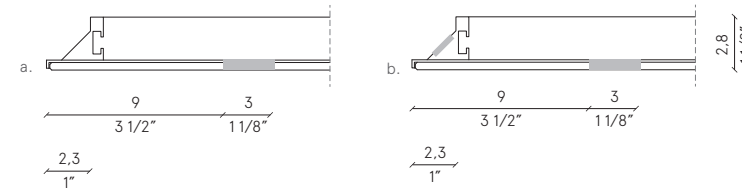

a. senza led | without led | sans led | mit LED | без светодиодов  
 b. con led | with led | avec led | ohne LED | со светодиодам

finiture | finishes | finitions | Oberflächen | отделки  
 alluminio anodizzato zero chimico | zero chemical anodised aluminum | aluminium anodisé zéro produit chimique | kein chemisch eloxiertes Aluminium | анодированный алюминий "химический ноль"

alluminio  
anodizzato





design Giuseppe Bavuso

EKOS H

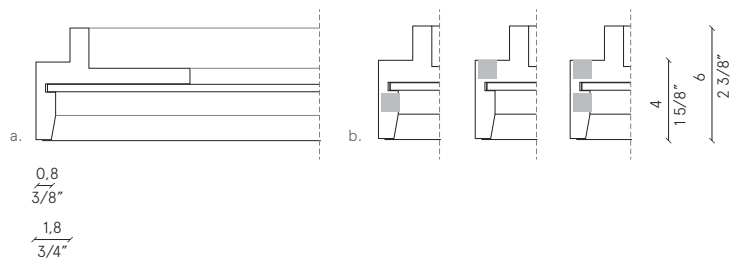

a. senza led | without led | sans led | mit LED | без светодиода  
 b. con led | with led | avec led | ohne LED | со светодиодом

modularità | modularity | modularité | Modularität | модульность

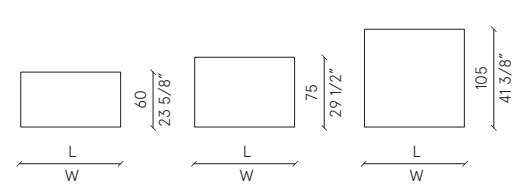

finiture | finishes | finitions | Oberflächen | отделки  
 metallo verniciato | lacquered metal | métal laqué | Lackiertes Metall | окрашенный металл



design Giuseppe Bavuso

EKOS H PLUS

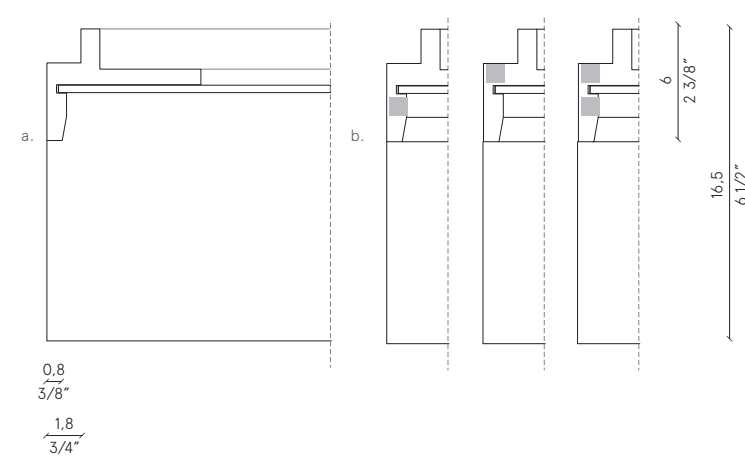

a. senza led | without led | sans led | mit LED | без светодиода  
 b. con led | with led | avec led | ohne LED | со светодиодом

modularità | modularity | modularité | Modularität | модульность

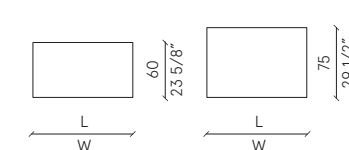

finiture | finishes | finitions | Oberflächen | отделки  
 metallo verniciato | lacquered metal | métal laqué | Lackiertes Metall | окрашенный металл





design Giuseppe Bavuso

EKOS V

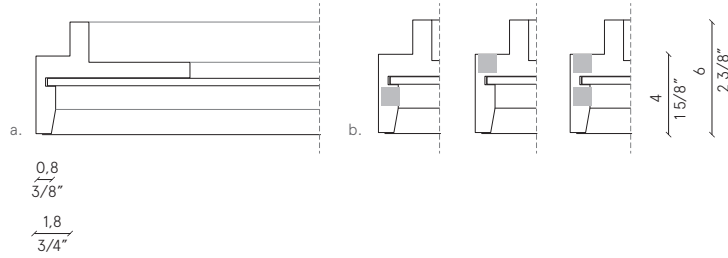

a. senza led | without led | sans led | mit LED | без светодиодов  
 b. con led | with led | avec led | ohne LED | со светодиодам

modularità | modularity | modularité | Modularität | модульность

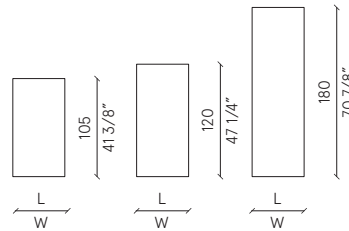

finiture | finishes | finitions | Oberflächen | отделки  
 metallo verniciato | lacquered metal | métal laqué | Lackiertes Metall | окрашенный металл



design Giuseppe Bavuso

EKOS H PLUS

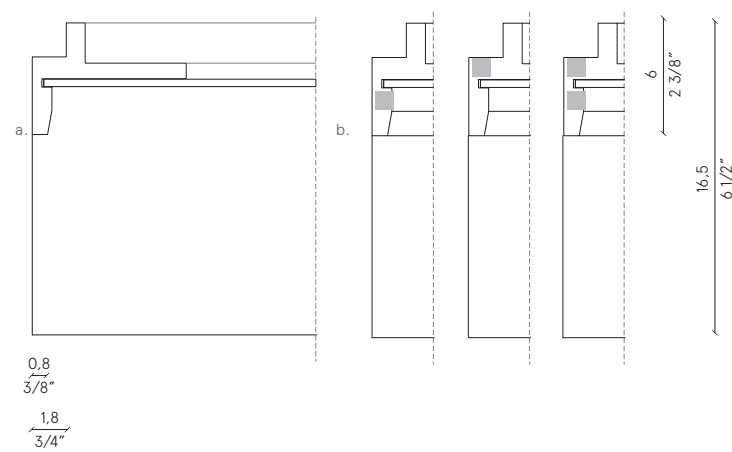

a. senza led | without led | sans led | mit LED | без светодиодов  
 b. con led | with led | avec led | ohne LED | со светодиодам

modularità | modularity | modularité | Modularität | модульность

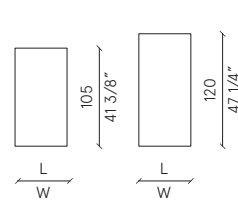

finiture | finishes | finitions | Oberflächen | отделки

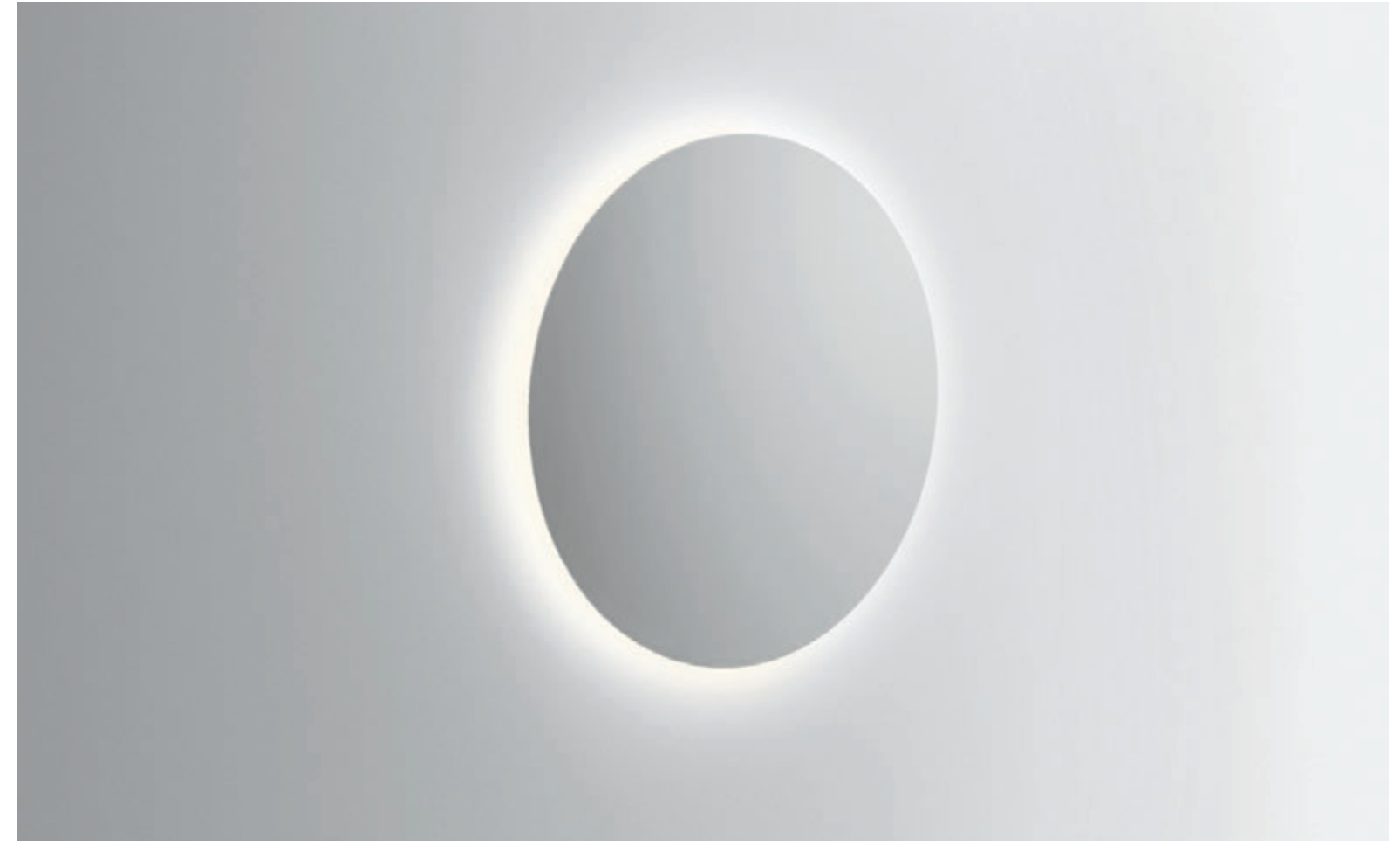

design Lievore Altherr

AIR

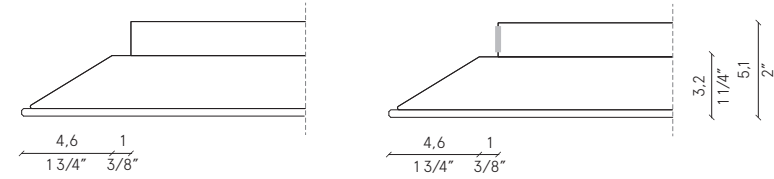

a. senza led | without led | sans led | mit LED | без светодиодов  
 b. con led | with led | avec led | ohne LED | со светодиодам

modularità | modularity | modularité | Modularität | модульность

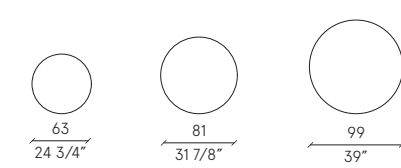

finiture | finishes | finitions | Oberflächen | отделки  
 laccato opaco | matt lacquered | laques mates | Matt Lackierung | матовые лакировки

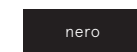



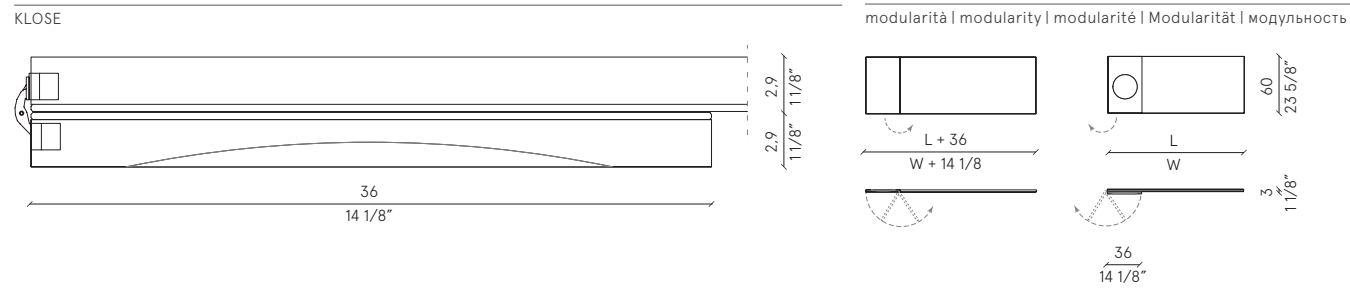

finiture pannello e lente ingranditore | panel finishes and magnifying glass | panneaux finitions et miroir magnifique | Oberflächenpanel und Vergrößerungsspiegel | отделки панели и увеличительное зеркало  
 laccati opachi e lucidi | matt and glossy lacquer | laques mates et brillantes | Matt- und Glanzlacken | матовые - гляцевые лакировки

22 colours

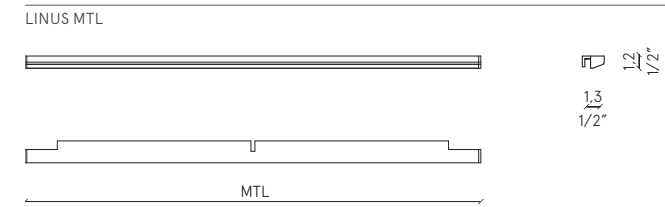

finiture | finishes | finitions | Oberflächen | отделки  
 alluminio anodizzato zero chimico | zero chemical anodised aluminium | aluminium anodisé  
 zéro produit chimique | kein chemisch eloxiertes Aluminium | анодированный алюминий  
 "химический ноль"

alluminio  
anodizzato

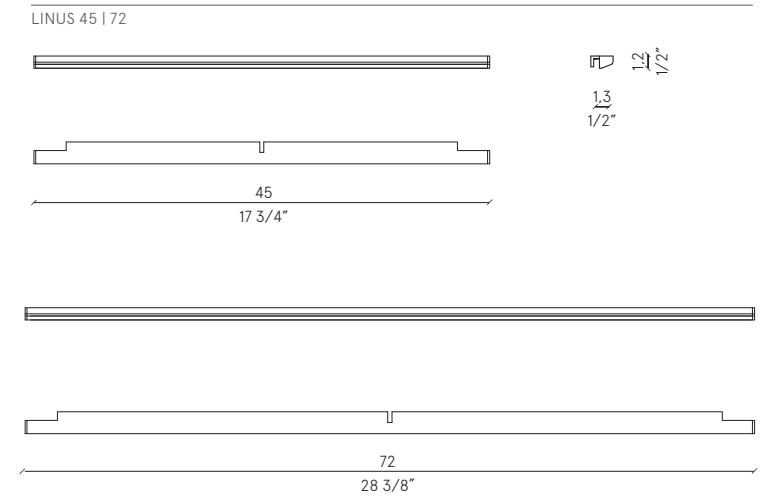

finiture | finishes | finitions | Oberflächen | отделки  
 alluminio anodizzato zero chimico | zero chemical anodised aluminium | aluminium anodisé  
 zéro produit chimique | kein chemisch eloxiertes Aluminium | анодированный алюминий  
 "химический ноль"

alluminio  
anodizzato

MOON



MOON

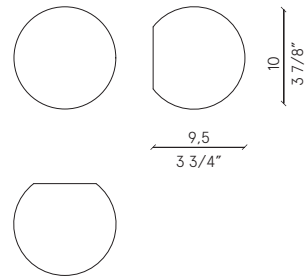

finiture | finishes | finitions | Oberflächen | отделки  
vetro | glass | verre | Glas | стекло

vetro

REGOLO



REGOLO

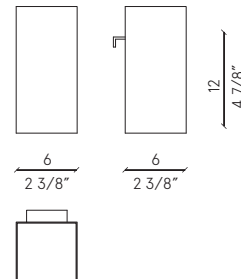

finiture | finishes | finitions | Oberflächen | отделки  
metallo verniciato | lacquered metal | métal laqué | Lackiertes Metall | окрашенный металл

bianco

FLAT



FLAT

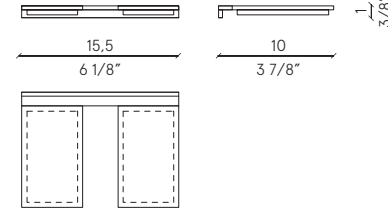

finiture | finishes | finitions | Oberflächen | отделки  
metallo verniciato | lacquered metal | métal laqué | Lackiertes Metall | окрашенный металл

bianco

KASIO



KASIO

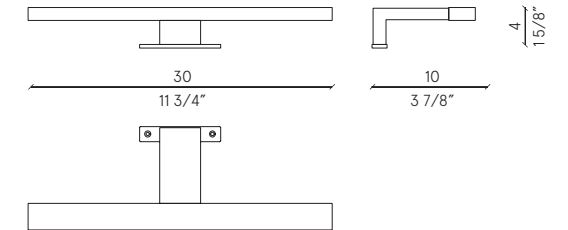

finiture | finishes | finitions | Oberflächen | отделки  
metallo | metal | métal | Metall | металл

cromo



# Inner equipment

SHAPE 01



SHAPE 01, P 47 - 51 cm | D 18 1/2" - 20 1/8"  
Zenit, Sintesi, One: base portlavabo | washbasin unit | meuble bas sous vasque  
Waschbeckenunterschrank | тумба для раковины

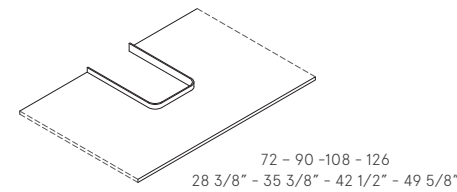

finiture | finishes | finitions | Oberflächen | отделки  
sintetico opaco | matt synthetic | synthétique mat | Matt Synthetisch | матовое соединение

brown

SHAPE 02



SHAPE 02, P 51 cm | D 20 1/8"  
Puro, Azuma: base portlavabo | washbasin unit | meuble bas sous vasque  
Waschbeckenunterschrank | тумба для раковины

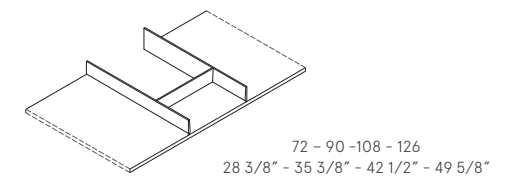

finiture | finishes | finitions | Oberflächen | отделки  
essenze opache | matt veneers | essences mates | matte Holze | матовые шпоны

rovere  
carbone

FRAME 01, P 47 - 51 cm | D 18 1/2" - 20 1/8"  
Puro, Zenit, Azuma, Sintesi: base portlavabo | washbasin unit | meuble bas sous vasque  
attrezzatura interna H 5 cm | internal equipment H 2" | équipement interne H 5 cm | innere Ausrüstung H 5 cm | внутреннее оснащение выс. 5 см

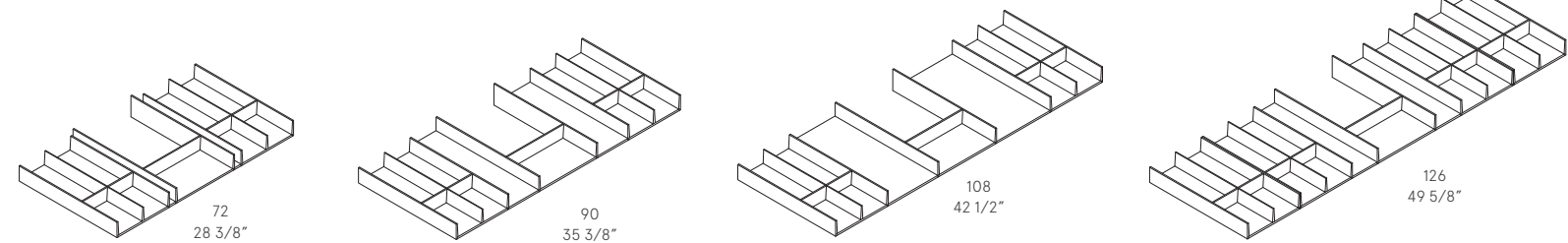

finiture | finishes | finitions | Oberflächen | отделки  
essenze opache | matt veneers | essences mates | matte Holze | матовые шпоны

rovere  
carbone



FRAME 02, P 47 - 51 cm | D 18 1/2" - 20 1/8"  
 base componibile | base unit | meuble bas | Einbau-Unterschrank | тумба  
 attrezzatura interna H 5 cm | internal equipment H 2" | équipement interne H 5 cm | innere Ausrüstung H 5 cm | внутреннее оснащение выс. 5 cm

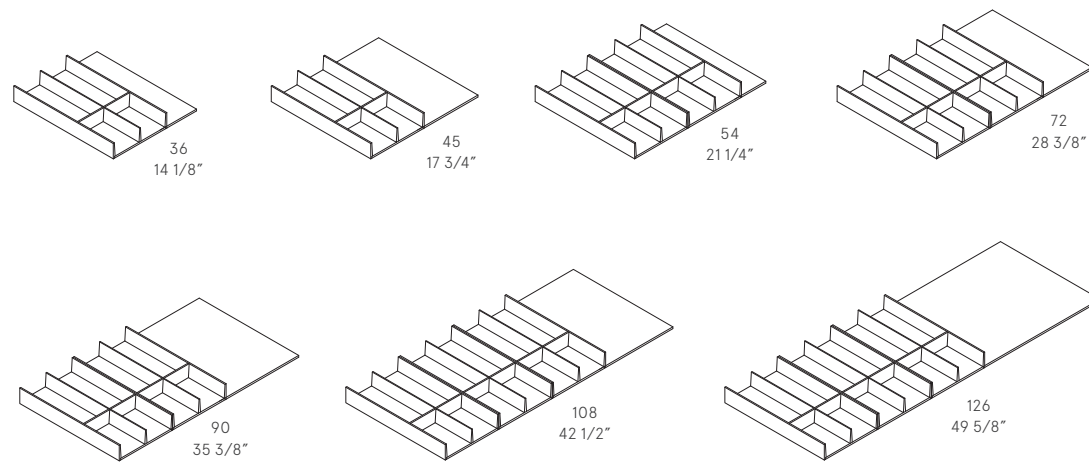

finiture | finishes | finitions | Oberflächen | отделки  
 essenze opache | matt veneers | essences mates | matte Holze | матовые шлоны

rovere  
 carbone



FRAME 03, P 47 - 51 cm | D 18 1/2" - 20 1/8"  
 base componibile | base unit | meuble bas | Einbau-Unterschrank | тумба  
 attrezzatura interna H 9,5 cm | internal equipment H 3 3/4" | équipement interne H 9,5 cm | innere Ausrüstung H 9,5 cm | внутреннее оснащение выс. 9,5 cm

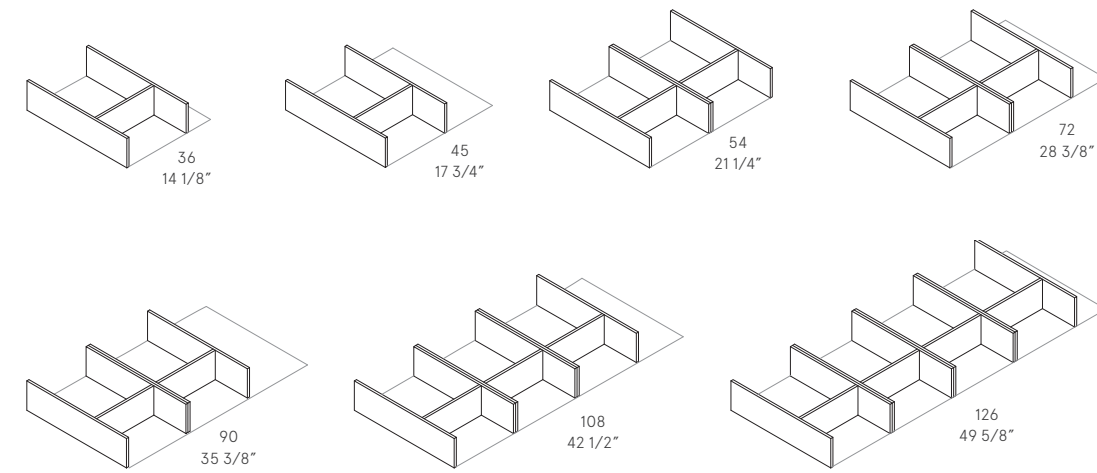

finiture | finishes | finitions | Oberflächen | отделки  
 vetri | glasses | verres | Gläser | стекла

fumè



# Technical data

3

Fjord Collection	406
Puro Collection	408
Zenit Collection	410
Azuma Collection	412
Roma Collection	414
Touch Collection	416
Sintesi Collection	418
One Collection	420
Finishes	422

# Technical data



gola | groove handle | gorge | Gehührung | паз inferiore | lower | inférieur | Niedriger | ниже

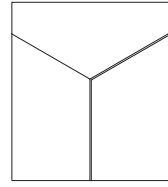

gola nella parte inferiore  
groove at the drawer bottom  
gorge au bas du tiroir  
Gehührung an der Unterseite der Schublade  
паз в нижней части

push pull | push latch | loqueteau push-pull | Touch-System | нажимная защелка

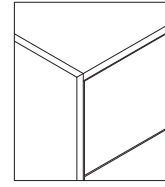

per aprire premere nella parte centrale  
push latch in the middle of the front  
ouverture par pression au milieu  
zum Öffnen in der Mitte drücken  
нажимная защелка в середине фасада

maniglia | handle | poignées | Griff | ручка

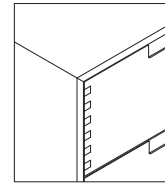

cassettiera  
base with drawers  
meuble avec tiroirs  
Schubladenschrank  
тумба с ящиками

finiture | finishes | finitions | Oberflächen | отделки

struttura, frontali, fianchi | structure, frontals, sides | structure, façades, côtés | Struktur, Fronten, Seiten | структура, фасады, боковые стенки  
laccati metallizzati | metallic lacquered | laques métallisés | Metallisierte Lackierung | металлизированные лакировки



frontali, fianchi, top | fronts, sides, tops | façades, côtés, plans | Fronten, Seiten, Platten | фасады, боковые стенки, столешницы

laccati opachi e lucidi spazzolati | matt lacquered and high glossy lacquered | laques mates et laques brillantes brossées | Matt und gebürstete glänzende Lackierung | матовые лакировки и брашированные глянцевые лакировки



essenze opache | matt veneers | mates essences | Matt Holze | матовые шпоны



ripiani | inner shelves | étagères internes | Ablagen | полки

laccati metallizzati | metallic lacquered | laques métallisés | Metallisierte Lackierung | металлизированные лакировки



essenze opache | matt veneers | mates essences | Matt Holze | матовые шпоны

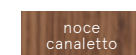

vetro | glass | verre  
Glas | стекло



sistema | system | système | System | система

H 33,5 cm P 51,2 cm | H 13 1/4" D 20 1/8"

a. vano a giorno | open element | élément à jour | offenes Fach | открытый элемент  
b. ripiani in Noce Canaletto | shelves in Noce Canaletto | étagères internes en Noce Canaletto | Ablagen aus Noce Canaletto | полки из Noce Canaletto  
ripiani in alluminio bugnato | shelves in embossed aluminium | étagères internes en aluminium larmé | Ablagen aus Aluminium | полки из Ашлар алюминевый  
ripiani in vetro fumé | shelves in Fumé glass | étagères internes en verre fumé | Ablagen aus Fumé Glass | полки из Fumé стекло

H 33,5 cm P 51,2 cm | H 13 1/4" D 20 1/8"

b. cassetto, vano a giorno | drawer, open element | tiroir, élément à jour | Schublade, offenes Fach | ящик, открытый элемент

H 33,5 cm P 51,2 cm | H 13 1/4" D 20 1/8"

c. base con 2 cassetti | base with 2 drawers | meuble avec 2 tiroirs | Schrank mit 2 Schubladen | тумба с 2 ящиками

H 33,5 cm P 51,2 cm | H 13 1/4" D 20 1/8"

d. base con 2 cassetti | base with 2 drawers | meuble avec 2 tiroirs | Schrank mit 2 Schubladen | тумба с 2 ящиками

H 33,5 cm P 51,2 cm | H 13 1/4" D 20 1/8"

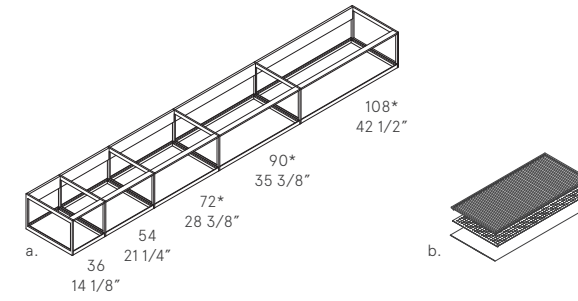

H 33,5 cm P 51,2 cm | H 13 1/4" D 20 1/8"

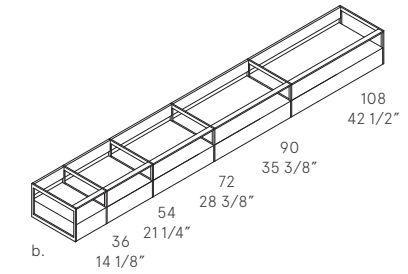

H 33,5 cm P 51,2 cm | H 13 1/4" D 20 1/8"

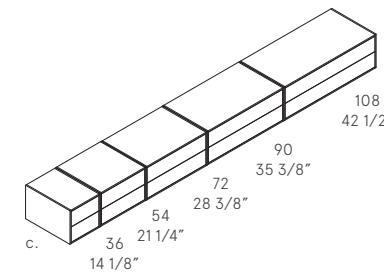

H 33,5 cm P 51,2 cm | H 13 1/4" D 20 1/8"

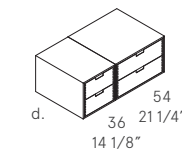

\* base lavabo | basin unit | meubles bas sous vasque | Waschbeckenunterschrank | тумбы для раковины

PURO COLLECTION

top, fianco di finitura e frontali a 45° | top, finished side and frontals 45° chamfer plan | côtés de finition et fronts avec chanfrein 45° | Platte, Seitenveredelung und Front 45 Grad | столешница, боковая стенка и фасады 45° град

gola | groove handle | gorge | Gehurung | I naz

M90 - superiore, frontale e laterale | upper, frontal, side | supérieure, frontal, latérale | oben, vor und seitlich | верхний, передний и боковой

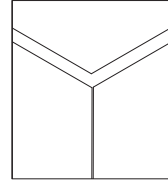

laccata, laccata anodizzata  
lacquered colour, lacquered anodized  
laquée, laques anodisés  
Lackiert, Lackiert anodisiert  
цветов, лакировки анодированы

finiture | finishes | finitions | Oberflächen | отделки

frontali, fianchi, gola, top | fronts, sides, groove handle, tops | façades, côtés, gorge, plans | Fronten, Seiten, Gehurung, Platten | фасады, боковые стенки, паз, столешницы  
laccati opachi e lucidi spazzolati | matt and glossy lacquers | laques mates et brillantes | Matt- und Glanzlacken | матовые - глянцевые лакировки  
vetro, vetro acidato | glass, etched glass | verre, verre gravé | Glas, Geätztes Glas | стекло, вытравленное стекло



frontali, fianchi, top | fronts, sides, tops | façades, côtés, plans | Fronten, Seiten, Platten | фасады, боковые стенки, столешницы  
essenze opache | matt veneers | mates essences | Matt Holze | матовые шпоны



marmi opachi | matt marbles | marbres mates | Matt Marmor | матовые мраморы

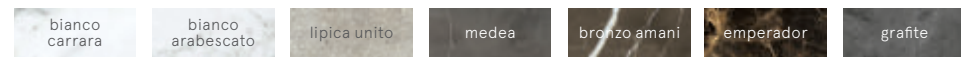

top | tops | plans | Platten | столешницы

sintetici | compounds | synthétiques | Kunststoff | соединений



\* opachi e lucidi | matt and glossy | mates et brillantes | Matt und glänzend | матовые и глянцевые

gola | groove handle | gorge | Gehurung | I naz

laccato anodizzato | lacquered anodised | laqué anodisé | lackiert eloxiert | лакированный анодированный



zoccolo | plinth | socle | Sockel | цоколь

laccato | lacquered | laqué | lackiert | лакированный

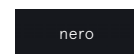

sistema | system | système | System | система

H 23,5 cm P 51 cm | H 9 1/2" D 20 1/8"

a. cassetto | drawer | tiroir | Schublade | ящик

H 35,5 cm P 51 cm | H 14" D 20 1/8"

a. cassetto | drawer | tiroir | Schublade | ящик

b. 2 cassetti | 2 drawers | 2 tiroirs | 2 Schubladen | 2 ящички

c. cassetto, vano a giorno | drawer, open element | tiroir, élément à jour | Schublade, offenes Fach | ящик, открытый элемент

H 46,1 cm P 51 cm | H 18 1/8" D 20 1/8"

a. cassetto | drawer | tiroir | Schublade | ящик

b. 2 cassetti | 2 drawers | 2 tiroirs | 2 Schubladen | 2 ящички

c. cassetto, vano a giorno | drawer, open element | tiroir, élément à jour | Schublade, offenes Fach | ящик, открытый элемент

H 72 cm P 51 cm | H 28 3/8" D 20 1/8"

a. cassetto, cassetto interno | drawer, inner drawer | tiroir, tiroir intérieur | Schublade, innere Schublade | ящик, внутренний ящик

b. anta, ripiano, cassetto interno | door, inner shelf, inner drawer | porte, étagère interne, tiroir intérieur | Türen, Ablage, innere Schublade | дверка, полка, внутренний ящик

c. 2 ante, cassetto interno | 2 doors, inner drawer | 2 portes, tiroir intérieur | 2 Türen, innere Schublade | 2 дверки, внутренний ящик

H 81,2 cm P 51 cm | H 32" D 20 1/8"

a. cassetto, cassetto interno | drawer, inner drawer | tiroir, tiroir intérieur | Schublade, innere Schublade | ящик, внутренний ящик

b. anta, ripiano, cassetto interno | door, inner shelf, inner drawer | porte, étagère interne, tiroir intérieur | Türen, Ablage, innere Schublade | дверка, полка, внутренний ящик

c. 2 ante, cassetto interno | 2 doors, inner drawer | 2 portes, tiroir intérieur | 2 Türen, innere Schublade | 2 дверки, внутренний ящик

H 23,5 cm | 9 1/4"

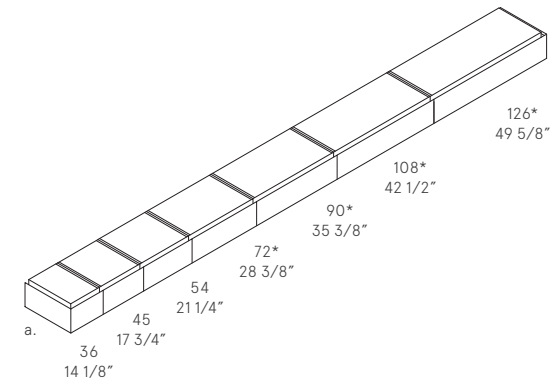

H 35,5 cm | 14"

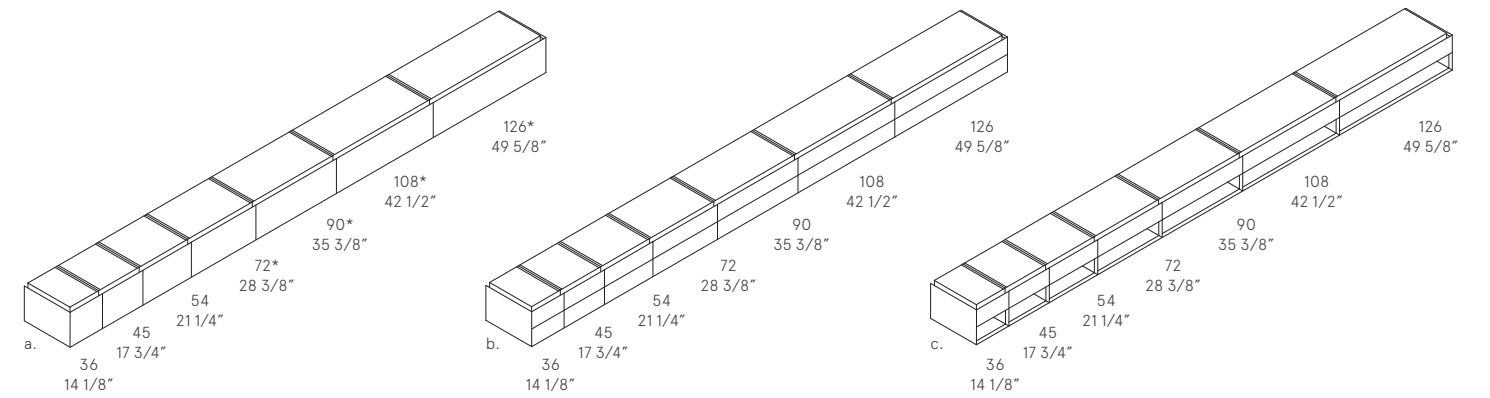

H 46,1 cm | 18 1/8"

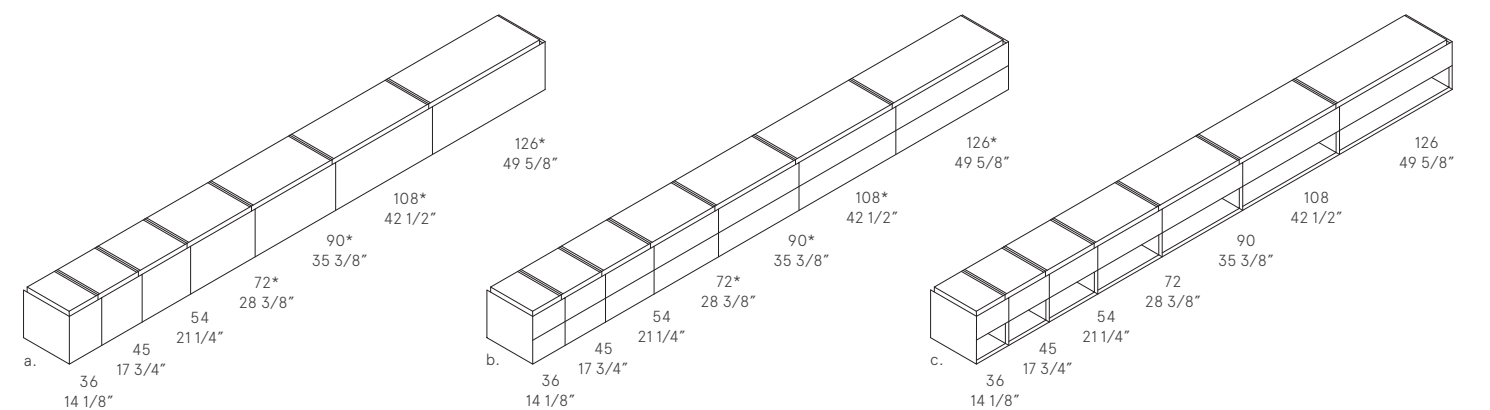

H 72 cm | 28 3/8"

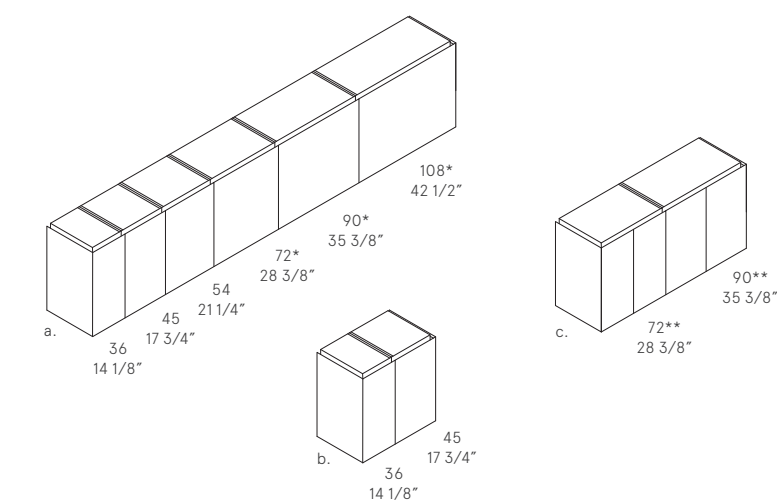

H 81,2 cm | H 32"

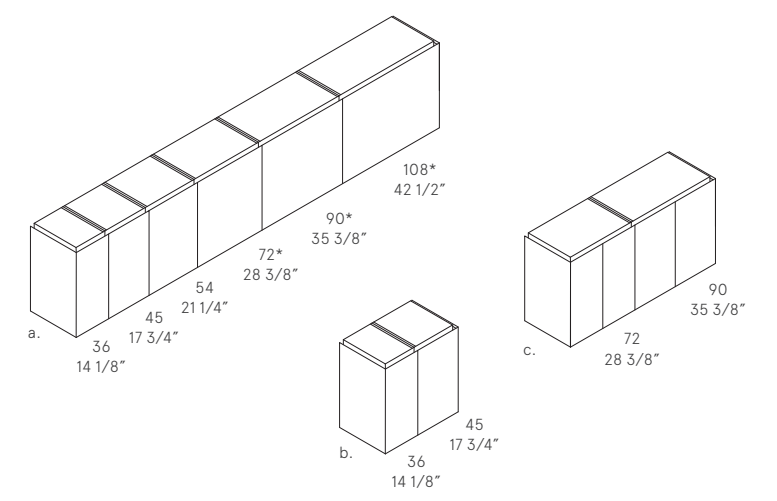

\* base lavabo | basin unit | meubles bas sous vasque | Waschbeckenunterschrank | тумбы для раковины | \*\* solo base lavabo | only basin unit | seule meubles bas sous vasque | nur Waschbecken unter Schrank  
только тумбы для раковины



ZENIT COLLECTION

top a 90°, fianco di finitura e frontali a 45° | top 90° chamfer, finished side and frontals 45° chamfer | plan avec chanfrein 90°, côtés de finition et fronts avec chanfrein 45° | Platte aus 90°, Seitenveredelung und Front 45°  
столешница 90° град, боковая стенка и фасады 45° град

gola | groove handle | gorge | Gehurung | наз  
M90 - superiore | upper | supérieure | oben | верхний

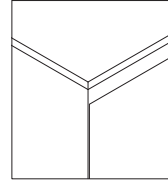

laccata, laccata anodizzata  
lacquered colour, lacquered anodized  
laquée, laques anodisés  
Lackiert, Lackiert anodisiert  
цветов, лакировки анодированы

gola | groove handle | gorge | Gehurung | наз  
M91 - centrale | central | centrale | mittlere | центральный

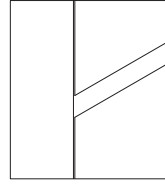

laccata, laccata anodizzata  
lacquered colour, lacquered anodized  
laquée, laques anodisés  
Lackiert, Lackiert anodisiert  
цветов, лакировки анодированы

finiture | finishes | finitions | Oberflächen | отделки

frontali, fianchi, gola, top | fronts, sides, groove handle, tops | façades, côtés, gorge, plans | Fronten, Seiten, Gehurung, Platten | фасады, боковые стенки, наз, столешницы  
laccati opachi e lucidi spazzolati | matt and glossy lacquers | laques mates et brillantes | Matt- und Glanzlacken | матовые - глянцевые лакировки  
vetro, vetro acidato | glass, etched glass | verre, verre gravé | Glas, Geätztes Glas | стекло, выравненное стекло



frontali, fianchi, top | fronts, sides, tops | façades, côtés, plans | Fronten, Seiten, Platten | фасады, боковые стенки, столешницы  
essenze opache | matt veneers | mates essences | Matt Holze | матовые шпоны

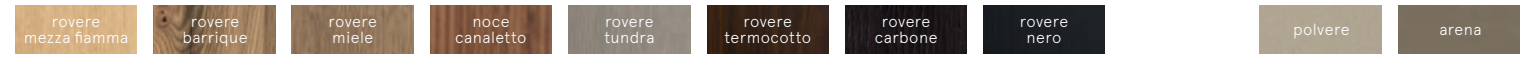

top | tops | plans | Platten | столешницы  
sintetici | compounds | synthétiques | Kunststoff | соединений

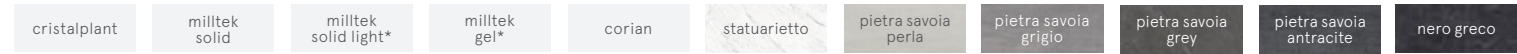

\*opachi e lucidi | matt and glossy | mates et brillantes | Matt und glänzend | матовые - глянцевые

marmi opachi | matt marbles | marbres mates | Matt Marmor | матовые мраморы

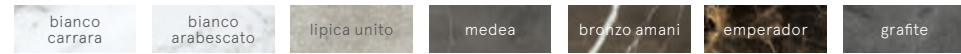

gola | groove handle | gorge | Gehurung | наз

laccato anodizzato | lacquered anodised | laqué anodisé | lackiert eloxiert | лакированный анодированный



zoccolo | plinth | socle | Sockel | цоколь

laccato | lacquered | laqué | lackiert | лакированный

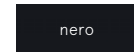

sistema | system | système | System | система

H 24 cm P 47 - 51 cm | H 9 1/2" D 18 1/2" - 20 1/8"

a. cassetto | drawer | tiroir | Schublade | ящик  
b. vano a giorno | open element | élément à jour | offenes Fach | открытый элемент

H 36 cm P 47 - 51 cm | H 14 1/8" D 18 1/2" - 20 1/8"

a. cassetto | drawer | tiroir | Schublade | ящик  
b. vano a giorno | open element | élément à jour | offenes Fach | открытый элемент

H 48 cm P 47 - 51 cm | H 18 7/8" D 18 1/2" - 20 1/8"

a. cassetto | drawer | tiroir | Schublade | ящик  
b. 2 cassetti | 2 drawers | 2 tiroirs | 2 Schubladen | 2 ящики  
c. cassetto, vano a giorno | drawer, open element | tiroir, élément à jour | Schublade, offenes Fach | ящик, открытый элемент

H 72 cm P 47 - 51 cm | H 28 3/8" D 18 1/2" - 20 1/8"

a. 2 cassetti | 2 drawers | 2 tiroirs | 2 Schubladen | 2 ящики

H 81 cm P 47 - 51 cm | H 32" D 18 1/2" - 20 1/8"

a. 2 cassetti | 2 drawers | 2 tiroirs | 2 Schubladen | 2 ящики

H 24 cm | 9 1/2"

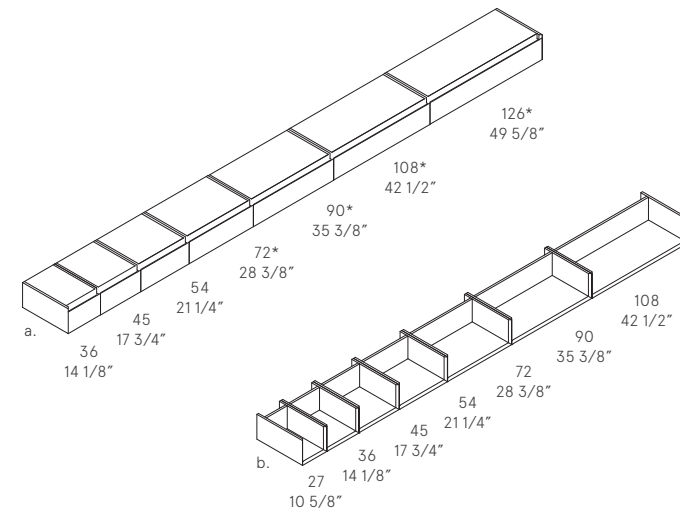

H 36 cm | 14 1/8"

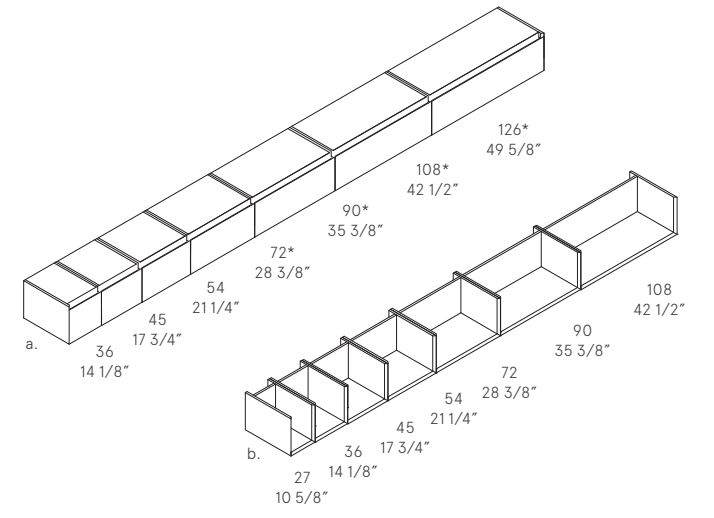

H 48 cm | 18 7/8"

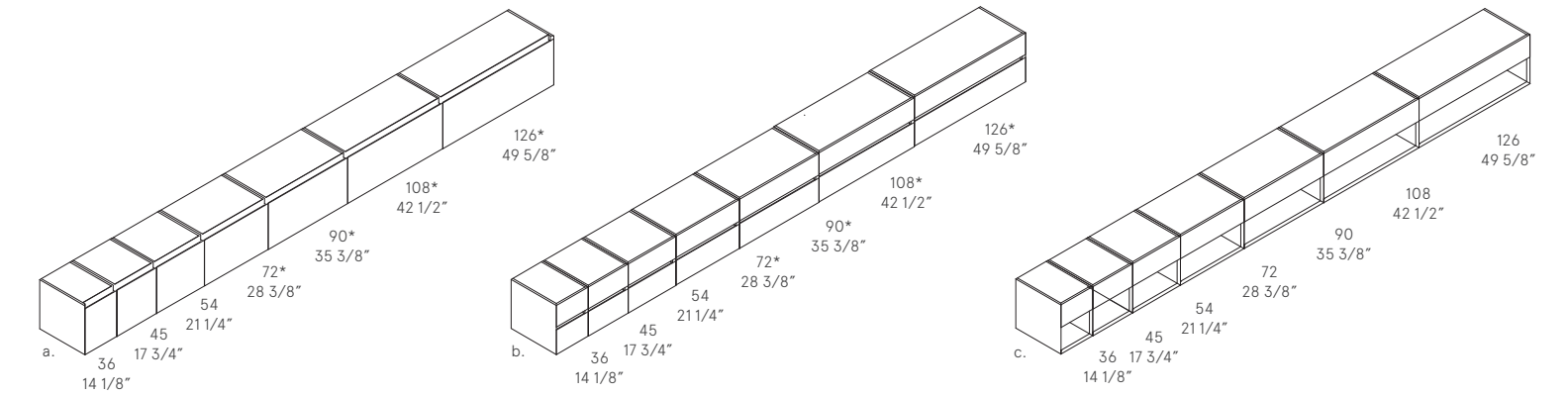

H 72 cm | 28 3/8"

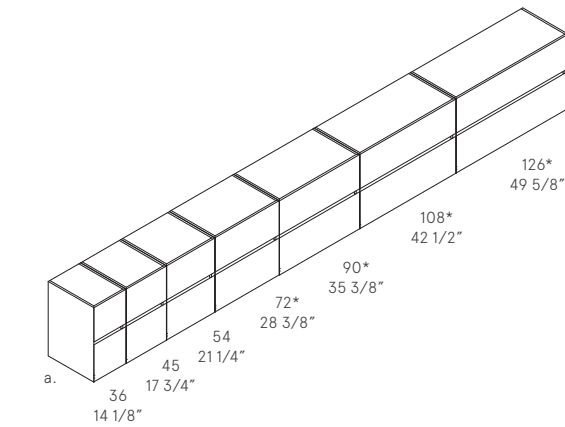

H 81 cm | H 31 7/8"

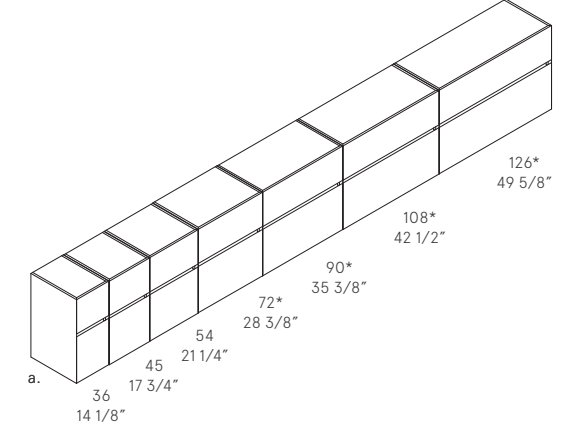

\* base lavabo | basin unit | meubles bas sous vasque | Waschbeckenunterschrank | тумбы для раковины

## AZUMA COLLECTION

top, fianco di finitura e frontali a 45° | top, finished side and frontals 45° chamfer | plan, côtés de finition et fronts avec chanfrein 45° | Platte, Seitenveredelung und Front 45 Grad | столешница, боковая стенка и фасады 45° град

gola | groove handle | gorge | Gehührung | паз inferiore | lower | inférieur | Niedriger | ниже

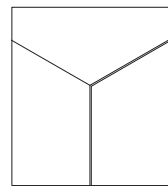

gola nella parte inferiore  
groove at the drawer bottom  
Gorge au bas du tiroir  
Gehührung an der Unterseite der Schublade  
паз в нижней части

finiture | finishes | finitions | Oberflächen | отделки

frontali, fianchi, top | fronts, sides, tops | façades, côtés, plans | Fronten, Seiten, Platten | фасады, боковые стенки, столешницы  
essenze opache | matt veneers | mates essences | Matt Holze | матовые шпоны



lavabo | washbasin | vasque | Waschbecken | раковина  
sintetico opaco | matt synthetic | synthétique mat | Matt Synthetisch | матовое соединение

crystalplant

esterno laccato opaco | matt lacquered exterior | extérieur laqué mat | Außenmattlack | внешняя поверхность в матовой лакировке



accessori | accessories | accessoires | Zubehör | аксессуары  
essenze opache | matt veneers | mates essences | Matt Holze | матовые шпоны

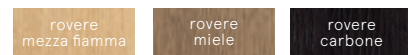

pouf | puff | пуф  
sughero | cork | liège | Kork | пробка



collezioni | collections | collections | Sammlungen | коллекции

H 16 cm P 51 | H 6 1/4" D 20 1/8"

base lavabo | basin unit | meubles bas sous vasque | Waschbeckenunterschrank | тумбы для раковины

a. top sospeso con cassetto | suspended top with drawer | plan suspendu avec tiroir | Hängende Platte mit Schublade | навесная столешница с ящиком  
b. top sospeso con 2 cassetti | suspended top with 2 drawers | plan suspendu avec 2 tiroirs | Hängende Platte mit 2 Schublade | навесная столешница с 2 ящиками

H 16 - 88 cm | H 6 1/4" - 34 5/8"

a. Azuma 45 lavabo appoggio | sit-on washbasin Azuma 45 | vasque à poser Azuma 45 | Waschbecken aufliegend Azuma 45 | накладная раковина Azuma 45  
b. Azuma 58 lavabo appoggio | sit-on washbasin Azuma 58 | vasque à poser Azuma 58 | Waschbecken aufliegend Azuma 58 | накладная раковина Azuma 58  
c. Azuma 88 lavabo a terra | floor-standing washbasin Azuma 88 | vasque au sol Azuma 88 | Waschbecken aufliegend Azuma 88 | напольная раковина Azuma 88

H 50 cm P a. 85 - b. 97 cm | H 19 5/8" D a. 33 1/2" - b. 38 1/4"

a. vasca, versione free-standing | bath, free standing version | Baignoire, version libre | Freistehende Badewanne | ванна, отдельно расположенная ванна  
b. vasca versione a parete | bath, wall-standing version | baignoire version au mur | Wandmontierte Badewanne | ванна, настенная версия  
c. vassoi Loto per vasca | Trays Loto for bathtub | plateaux pour baignoire Loto | Tablettts Loto für Badewanne | односы для ванны Loto

H 27 - 35,2 cm P 44,5 cm | H 10 5/8" - 13 7/8" D 17 1/2"

a. panca a listelli Zen | slat bench banc | à lattes Zen | Lattenbank Zen | скамья "Zen" из реек

H 44 - 34 cm P 35 - 40 cm | H 17 3/8" - 13 3/8" D 13 3/4 - 15 3/4"

a. Maki 1 pouff in sughero | stool made of cork Maki 1 | pouf en liège Maki 1 | Kork-Pouf Maki 1 | пробковый пуф Maki 1  
b. Maki 2 pouff in sughero | stool made of cork Maki 2 | pouf en liège Maki 2 | Kork-Pouf Maki 2 | пробковый пуф Maki 2

H 23,4 - 38 - 85 - 156 - 135 cm P 11 - 10,5 - 17 - 24 - 39 cm | H 13 1/4" D 4 3/8" - 4 1/8" - 6 3/4" - 9 1/2" - 15 3/8"

a. Toro appendino da parete | wall-mounted clothes hanger Toro | porte-manteau mural Toro | Wandhänger Toro | настенная вешалка Toro  
b. Toro porta salviette | towel rack Toro | porte-serviettes Toro | porte-manteau au sol "Toro" | Handtuchhalter Torol | полотенцедержатель Toro  
c. Toro appendino da terra | Toro floor-mounted clothes hanger | porte-manteau au sol "Toro" | Toro Hänger auf Boden | Напольная вешалка "Toro"  
d. Toro sedia con portasciugamani | Toro chair with towelholder | Toro chaise avec porte-serviettes | Toro Stuhl mit Handtuchhalter | "Toro" стул с полотенцедержателем

H 175 - 195 - 155 cm P 4,5 cm | H 68 7/8" - 76 3/4" - 61 D 13 3/4"

a. paravento centro stanza Levante | screen centre of room Levante | paravent centre de pièce Levante | Raummitte Bildschirm Levante | ширма в центре комнаты Levante

H 16 cm P 51 | H 6 1/4" D 20 1/8"

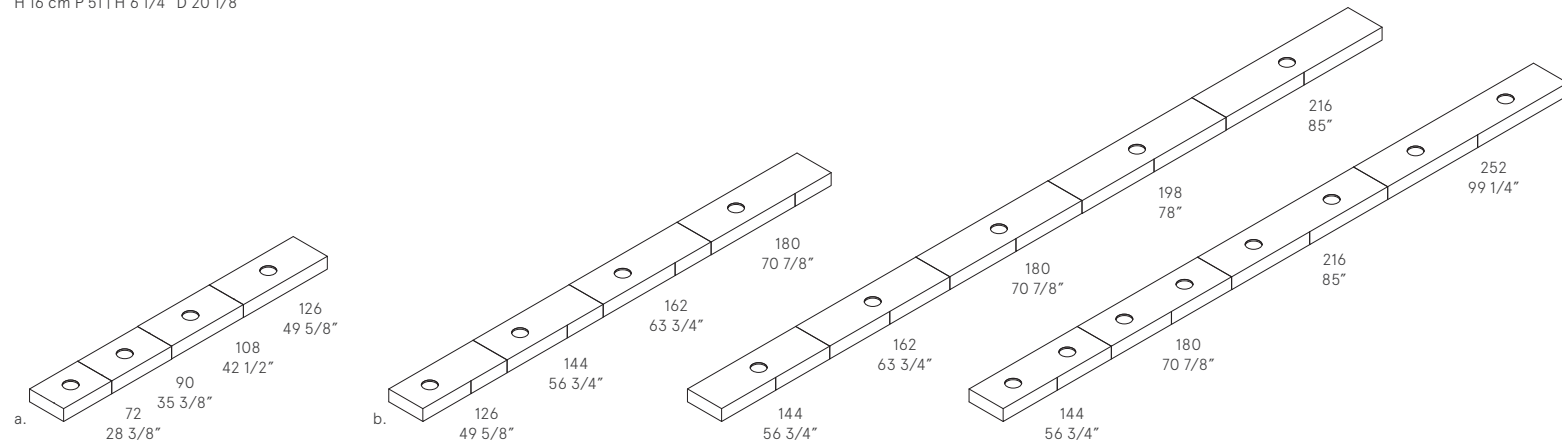

H 16 - 88 cm | H 6 1/4" - 34 5/8"

H 50 cm P a. 85 - b. 97 cm | H 19 5/8" D a. 33 1/2" - b. 38 1/4"



H 27 - 35,2 cm P 44,5 cm | H 10 5/8" - 13 7/8" D 17 1/2"

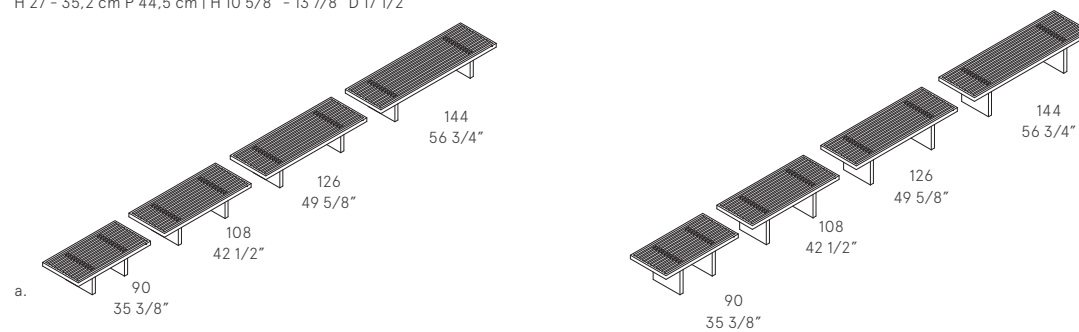

H 23,4 - 38 - 85 - 156 - 135 cm P 11 - 10,5 - 17 - 24 - 39 cm | H 13 1/4" D 4 3/8" - 4 1/8" - 6 3/4" - 9 1/2" - 15 3/8"

H 44 - 34 cm P 35 - 40 cm | H 17 3/8" - 13 3/8" D 13 3/4 - 15 3/4"

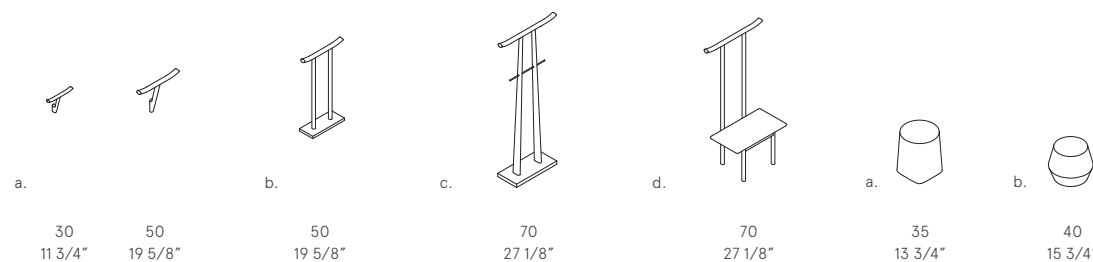

H 175 - 195 - 155 cm P 4,5 cm | H 68 7/8" - 76 3/4" - 61 D 13 3/4"

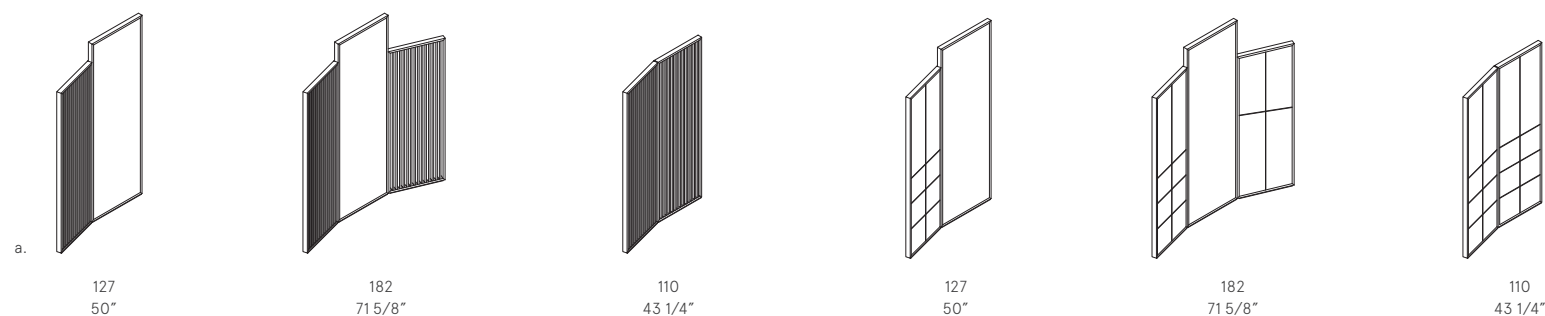



## ROMA COLLECTION

finiture | finishes | finitions | Oberflächen | отделки

lavabo | washbasin | vasque | Waschbecken | раковина  
ceramica opaca | matt ceramic | céramique mate | Mattkeramik | матовая керамика



Roma III, Roma IV e vasca | and bathtub | et baignoire | und Badewanne | и ванна

lavabo, zoccolo | washbasin, plinth | vasque, socle | Waschbecken, Sockel | раковина, цоколь  
marmi e pietre lisce | smooth marble and stones | marbres et pierres lisses | Marmor und glatte Steine | мрамор и гладкие камни

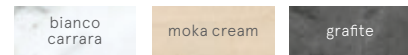

base | meuble | Unterschrank | тумба  
marmi e pietre irregolari | irregular marble and stones | marbres et pierres irrégulières | Marmor und unregelmäßige Steine | мрамор и камни с неровной поверхностью

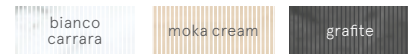

zoccolo | plinth | socle | Sockel | цоколь  
pietra a spacco solo per lavabo Roma IV | cleft finish stone only for Roma IV | pierres fendues seulement pour Roma IV | Brucksteine nur für Roma IV | камень с отделкой рваные только для Roma IV

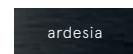

Roma I, Roma II

base | meuble | Unterschrank | тумба  
essenze opache | matt veneers | mates essences | Matt Holze | матовые шпоны

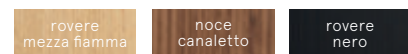

lavabo | washbasin | vasque | Waschbecken | раковина  
ceramica opaca | matt ceramic | céramique mate | Mattkeramik | матовая керамика



fascia | strip | bande | Metallband | полоса



portasciugamano, specchi | towel holder, mirror | porte-serviette, miroir | Handtuchhalter, Spiegel | вешалка для полотенец, зеркало

accessori | accessories | accessoires | Zubehör | аксессуары  
acciaio | steel | acier | Stahl | сталь

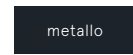

collezioni | collections | collections | Sammlungen | коллекции

H 16 - 25 cm | H 6 1/4" - 9 7/8"

- a. Roma 16 lavabo in appoggio | sit-on washbasin Roma 16 | vasque à poser Roma 16 | Auflagewaschbecken Roma 16 | накладная раковина Roma 16  
b. Roma 25 lavabo in appoggio | sit-on washbasin Roma 25 | vasque à poser Roma 25 | Auflagewaschbecken Roma 25 | накладная раковина Roma 25

H 88 cm | H 34 5/8"

- a. Roma III lavabo a terra | floor-standing washbasin Roma III | vasque au sol Roma III | Standwaschbecken Roma III | напольная раковина Roma III  
b. Roma IV lavabo a terra | floor-standing washbasin Roma IV | vasque au sol Roma IV | Standwaschbecken Roma IV | напольная раковина Roma IV  
c. Roma I lavabo a terra | floor-standing washbasin Roma I | vasque au sol Roma I | Standwaschbecken Roma I | напольная раковина Roma I  
d. Roma II lavabo a terra | floor-standing washbasin Roma II | vasque au sol Roma II | Standwaschbecken Roma II | напольная раковина Roma II  
e. Roma I lavabo a terra con distanziale | floor-standing washbasin Roma I with spacer | vasque au sol Roma I avec entretoise | Roma I, Waschbecken am Bonden mit Abstandshalter  
напольная раковина Roma I | раковина с проставкой  
f. Roma II lavabo a terra con distanziale | floor-standing washbasin Roma II with spacer | vasque au sol Roma II avec entretoise | Roma II, Waschbecken am Bonden mit Abstandshalter  
напольная раковина Roma II | раковина с проставкой

H 50 cm P 80 cm | H 19 5/8" D 31 1/2"

vasca | bathtub | baignoire | Badewanne | ванна

H 80 cm P 25,3 cm | H 31 1/2" D 10"

portasciugamano | towel holder | porte-serviette | Handtuchhalter | вешалка для полотенец

H 200 - 170 cm P 4 cm | H 78 3/4" - 66 7/8" D 15/8"

- a. specchiera | mirror | miroir | Spiegel | зеркало  
b. specchiera, anta girevole | mirror, revolving mirror | miroir, porte pivotante | Spiegel mit Drehtür | зеркало, поворотная створка

H 16 - 25 cm | H 6 1/4" - 9 7/8"

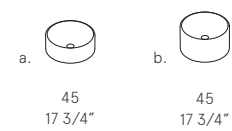

H 88 cm | H 34 5/8"

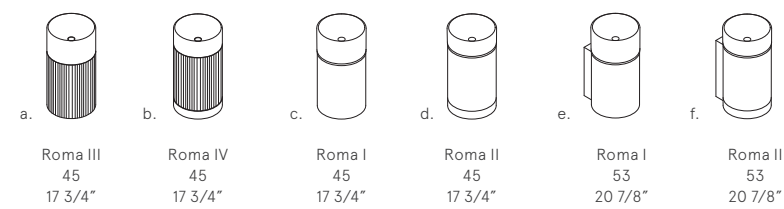

H 50 cm P 80 cm | H 19 5/8" D 31 1/2"

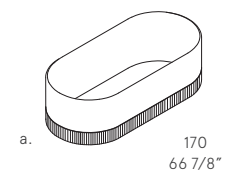

H 80 cm P 25,3 cm | H 31 1/2" D 10"

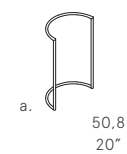

H 200 - 170 cm P 4 cm | H 78 3/4" - 66 7/8" D 15/8"

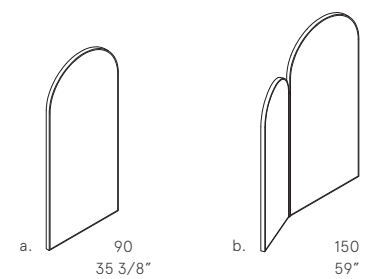

base monoblocco | monoblock | meuble monobloc | Monoblock-Unterschrank | моноблочная тумба

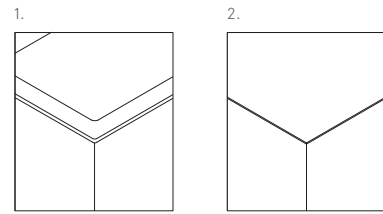

1. lavabo milltek solid, 2. lavabo in marmo  
 1. milltek solid washbasin, 2. washbasin in marble  
 1. vasque en milltek solid, 2. vasque en marbre  
 1. Waschbecken aus milltek solid, 2. Becken aus Marmor  
 1. раковина из milltek solid, 2. раковина из мрамора

push-pull | push-latch | loqueteau push-pull | Touch-System | нажимная защелка

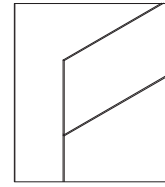

per aprire premere nella parte centrale  
 push latch in the middle of the front  
 ouverture par pression au milieu  
 zum Öffnen in der Mitte drücken  
 нажимная защелка в середине фасада

H 88 cm P 40 cm | H 34 5/8" D 15 3/4"

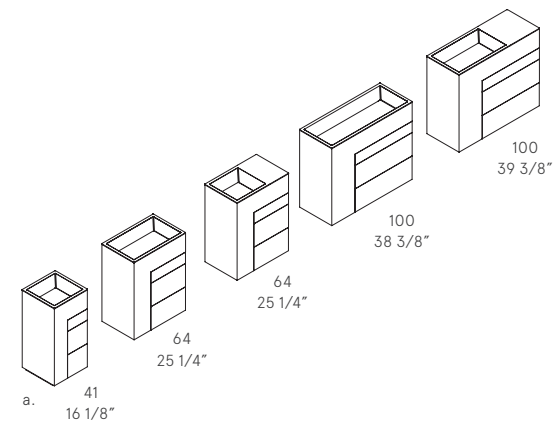

H 88 cm P 48 cm | H 34 5/8" D 18 7/8"

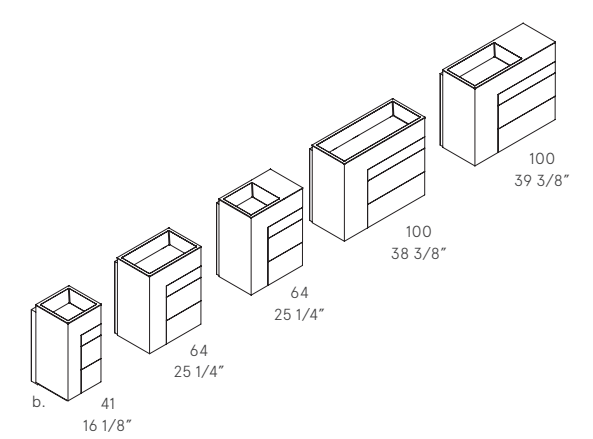

finiture | finishes | finitions | Oberflächen | отделки

frontali, fianchi | fronts, sides | façades, côtés | Fronten, Seiten | фасады, боковые стенки  
laccati opachi | matt lacquers | laques mates | Matt Gläser | матовые лакировки

essenze opache | matt veneers | mates essences | Matt Holz | матовые шпоны



abete | fir | sapin | Tanne | береза



top | tops | plans | Platten | столешницы

sintetico opaco | matt synthetic | synthétique mat | Matt Synthetisch | матовое соединение



zoccolo | plinth | socle | Sockel | цоколь

laccato | lacquered | laqué | lackiert | лакированный

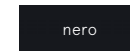

frontali, fianchi, lavabo | fronts, sides, washbasin | façades, côtés, vasque | Fronten, Seiten, Waschbecken | фасады, боковые стенки, раковина

marmi opachi | matt marbles | marbres mates | Matt Marmor | матовые мраморы

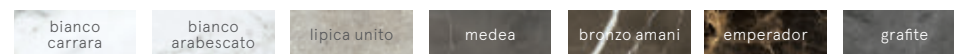

sistema | system | système | System | система

H 88 cm P 40 cm | H 34 5/8" D 15 3/4"

a. 3 cassetti, lavabo Full o Short in Milltek Solid, scarico a terra  
 3 drawers, Milltek Solid washbasin Full or Short, floor drain  
 3 tiroirs, vasque Full o Short in Milltek Solid, évacuation au sol  
 3 Schubladen, Waschbecken Full o Short aus Milltek Solid, Bodenabfluss  
 3 ящика, раковина Full o Short из Milltek Solid, со сливом на полу

H 88 cm P 48 cm | H 34 5/8" D 18 7/8"

b. 3 cassetti, lavabo Full o Short in Milltek Solid, scarico a parete  
 3 drawers, washbasin Full or Short Milltek Solid, wall drain  
 3 tiroirs, lavabo Full ou Short Milltek Solid, évacuation au mur  
 3 Schubladen, Becken Full oder Short Milltek Solid, Wandablauf  
 3 ящика, раковина Full или Short из Milltek Solid, со сливом в стену

H 88 cm P 40 cm | H 34 5/8" D 15 3/4"

c. 3 cassetti, lavabo Full o Short in marmo, scarico a terra  
 3 drawers, washbasin Full or Short in marble, floor drain  
 3 tiroirs, lavabo Full ou Short en Marbre, évacuation au sol  
 3 Schubladen, Becken Full oder Short aus Marmor, Bodenablauf  
 3 ящика, раковина Full или Short из мрамора, со сливом на полу

H 88 cm P 48 cm | H 34 5/8" D 18 7/8"

d. 3 cassetti, lavabo Full o Short in marmo, scarico a parete  
 3 drawers, washbasin Full or Short in marble, wall drain  
 3 tiroirs, lavabo Full ou Short en Marbre, évacuation au mur  
 3 Schubladen, Becken Full oder Short aus Marmor, Wandablauf  
 3 ящика, раковина Full или Short из мрамора, со сливом в стену

H 88 cm P 40 cm | H 34 5/8" D 15 3/4"

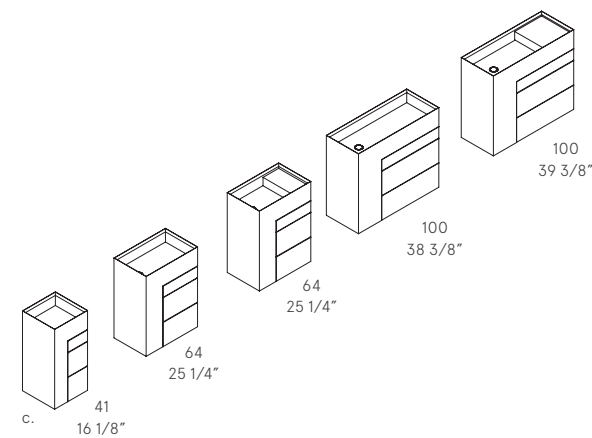

H 88 cm P 48 cm | H 34 5/8" D 18 7/8"

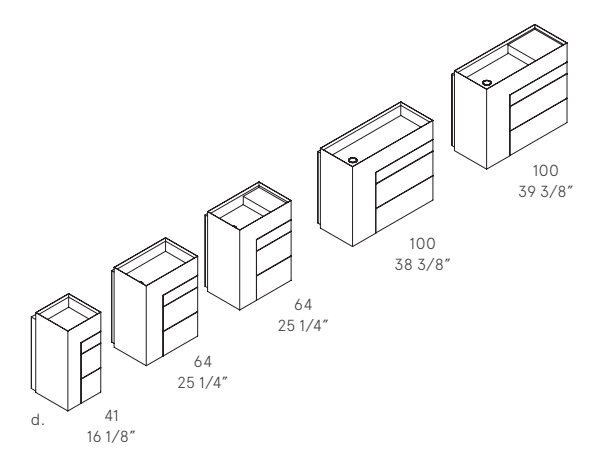



SINTESI COLLECTION

top, fianco di finitura e frontali a 90° | top, finished side and frontals 90° chamfer | plan, côtés de finition et fronts avec chanfrein 90° | Platte, Seitenveredelung und Front 90 Grad | столешница, боковая стенка и фасады 90° град

maniglia | handle | poignées | Griff | ручка M051

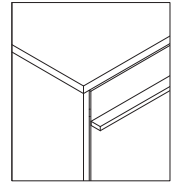

laccata  
lacquered colour  
laquée  
Lackiert  
цветов

push pull | push latch | loqueteau push-pull | Touch-System | нажимная защелка

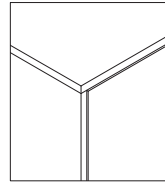

per aprire premere nella parte centrale  
push latch in the middle of the front  
ouverture par pression au milieu  
zum Öffnen in der Mitte drücken  
нажимная защелка в середине фасада

gola | groove handle | gorge | Gehurung | наз M90 - superiore | upper | supérieure | oben | верхний

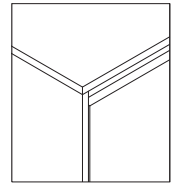

laccata, laccata anodizzata  
lacquered colour, lacquered anodized  
laquée, laques anodisés  
Lackiert, Lackiert anodisiert  
цветов, лакировки анодированы

gola | groove handle | gorge | Gehurung | наз M91 - centrale | central | centrale | mittlere | центральный

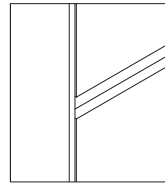

laccata, laccata anodizzata  
lacquered colour, lacquered anodized  
laquée, laques anodisés  
Lackiert, Lackiert anodisiert  
цветов, лакировки анодированы

fniture | finishes | finitions | Oberflächen | отделки

frontali, fianchi, gola, top, maniglia | fronts, sides, groove handle, tops, handle | façades, côtés, gorge, plans, poignées | Fronten, Seiten, Gehurung, Platten, Handgriffe | фасады, боковые стенки, наз, столешницы, ручка  
laccati opachi e lucidi spazzolati | matt and glossy lacquers | laques mates et brillantes | Matt- und Glanzlacken | матовые - глянецовые лакировки  
vetro, vetro acidato | glass, etched glass | verre, verre gravé | Glas, Geätztes Glas | стекло, вытравленное стекло



frontali, fianchi, top | fronts, sides, tops | façades, côtés, plans | Fronten, Seiten, Platten | фасады, боковые стенки, столешницы  
essenze opache | matt veneers | mates essences | Matt Holze | матовые шпоны



nobilitato | faced panels | mélamine | Melaminbeschichtete Spanplatten | меламин

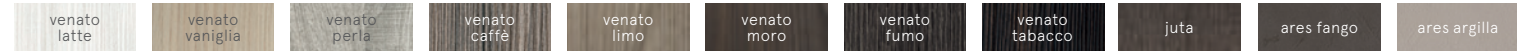

top | tops | plans | Platten | столешницы

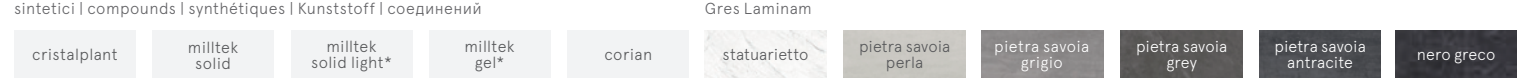

\*opachi e lucidi | matt and glossy | mates et brillantes | Matt und glänzend | матовые - глянецовые

marmi opachi | matt marbles | marbres mates | Matt Marmor | матовые мраморы

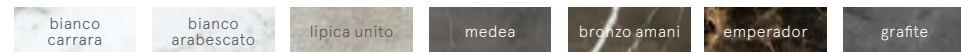

gola | groove handle | gorge | Gehurung | наз

laccato anodizzato | lacquered anodised | laqué anodisé | lackiert eloxiert | лакированный анодированный



zoccolo | plinth | socle | Sockel | цоколь

laccato | lacquered | laqué | lackiert | лакированный

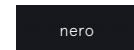

sistema | system | système | System | система

H 24 cm P 38,8 - 47 - 51 cm | H 9 1/2" D 15 1/4" - 18 1/2" - 20 1/8"

a. cassetto | drawer | tiroir | Schublade | ящик  
b. vano a giorno | open element | élément à jour | offenes Fach | открытый элемент

H 36 cm P 38,8 - 47 - 51 cm | H 14 1/8" D 15 1/4" - 18 1/2" - 20 1/8"

a. cassetto | drawer | tiroir | Schublade | ящик  
b. vano a giorno | open element | élément à jour | offenes Fach | открытый элемент  
c. cassetto, vano a giorno | drawer, open element | tiroir, élément à jour | Schublade, offenes Fach | ящик, открытый элемент

H 48 cm P 38,8 - 47 - 51 cm | H 18 7/8" D 15 1/4" - 18 1/2" - 20 1/8"

a. cassetto | drawer | tiroir | Schublade | ящик  
b. anta, ripiano | door, inner shelf | porte, étagère interne | Türen, Ablage | дверка, полка  
c. 2 cassetti | 2 drawers | 2 tiroirs | 2 Schubladen | 2 ящика  
d. ante | 2 doors | 2 portes | 2 Türen | 2 дверки  
e. vano a giorno | open element | élément à jour | offenes Fach | открытый элемент  
f. vano portasciugamano | open vanity | élément à jour avec porte serviettes | Offenes Fach mit Handtuchhalter | открытый элемент прав с полотенцедержателем

H 72 cm P 38,8 - 47 - 51 cm | H 28 3/8" D 15 1/4" - 18 1/2" - 20 1/8"

a. 2 cassetti | 2 drawers | 2 tiroirs | 2 Schubladen | 2 ящика  
b. anta, ripiano, cassetto interno | door, inner shelf, inner drawer | porte, étagère interne, tiroir intérieur | Türen, Ablage, innere Schublade | дверка, полка, внутренний ящик  
c. 2 ante, ripiano | 2 doors, inner shelf | 2 portes, tagère interne | 2 Türen, Ablage | 2 дверки, полка

H 81 cm P 38,8 - 47 - 51 cm | H 32" D 15 1/4" - 18 1/2" - 20 1/8"

a. 2 cassetti | 2 drawers | 2 tiroirs | 2 Schubladen | 2 ящика  
b. anta, ripiano, cassetto interno | door, inner shelf, inner drawer | porte, étagère interne, tiroir intérieur | Türen, Ablage, innere Schublade | дверка, полка, внутренний ящик  
c. 2 ante, ripiano | 2 doors, inner shelf | 2 portes, tagère interne | 2 Türen, Ablage | 2 дверки, полка

H 24 cm | 9 1/2"

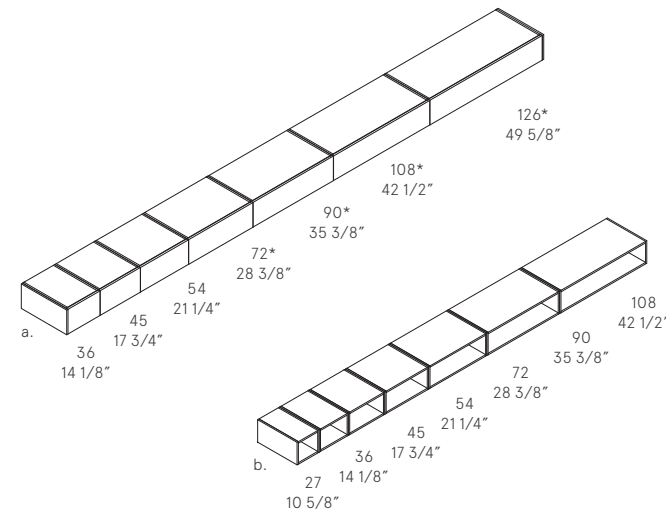

H 36 cm | 14 1/8"

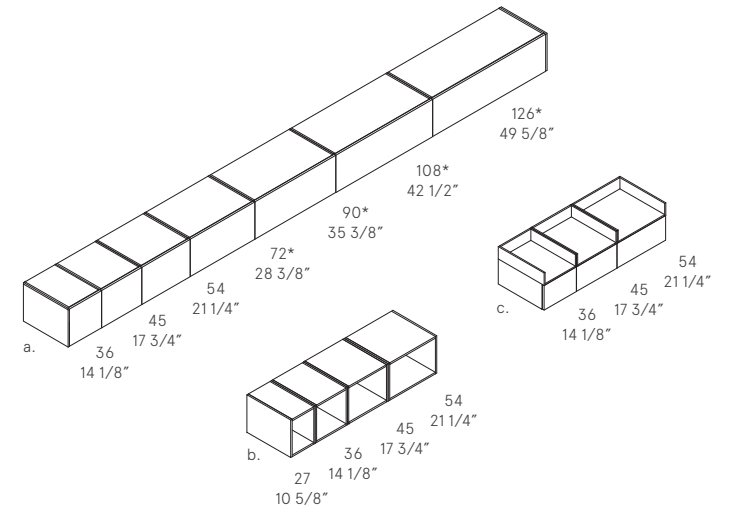

H 48 cm | 18 7/8"

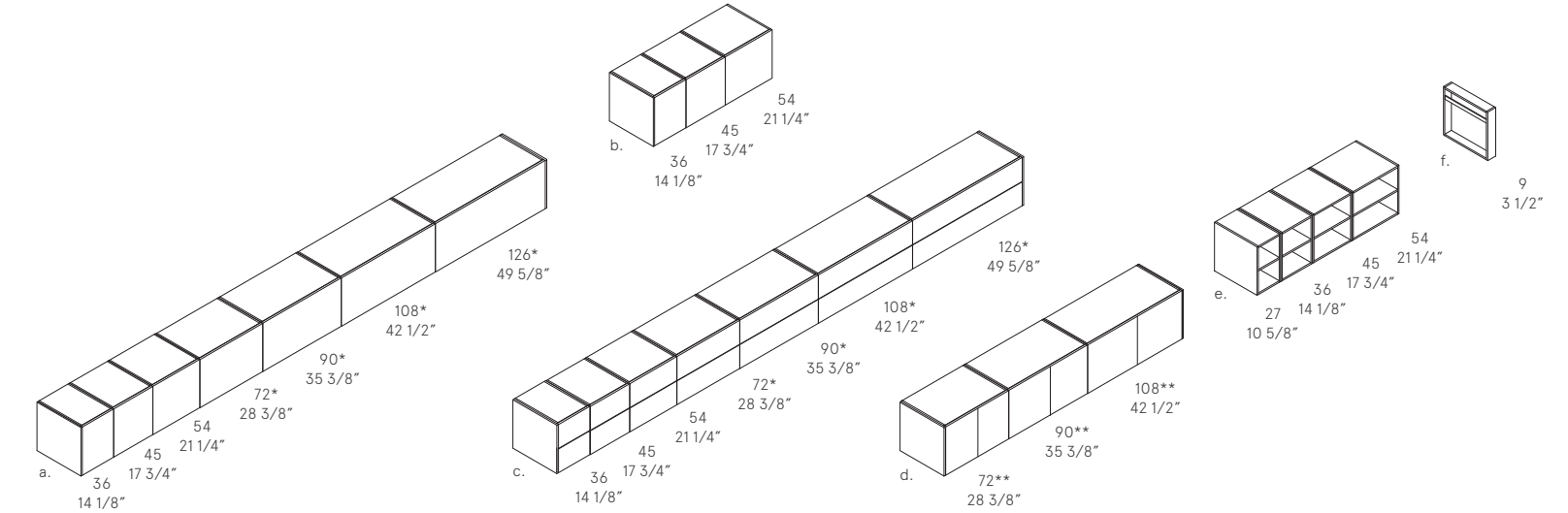

H 72 cm | 28 3/8"

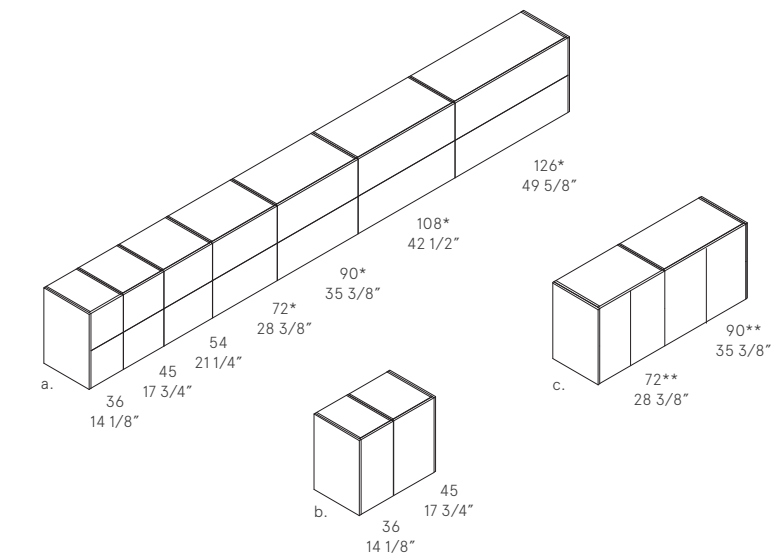

H 81 cm | H 31 7/8"

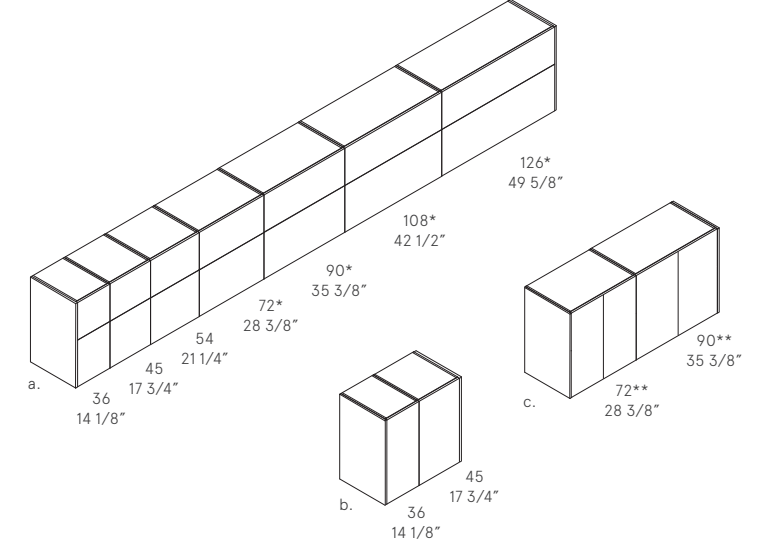

L 126 disponibile solo per P 47-51 cm | W 126 available only for D 47-51 cm | L 126 disponible uniquement pour P 47-51 cm | L 126 verfügbar nur für T.47-51 cm | Ш 126 доступен только для Г 47-51 cm  
\* base lavabo | basin unit | meubles bas sous vasque | Waschbeckenunterschrank | тумбы для раковины | \*\* solo base lavabo | only basin unit | seule meubles bas sous vasque | nur Waschbecken unter Schrank  
только тумбы для раковины.

top e frontali a 90° | top and frontals 90° | chamfer plan et fronts avec chanfrein 90° | Platte und Front 90 Grad | столешница и фасады 90° град

maniglia | handle | poignées | Griff | ручка  
M800

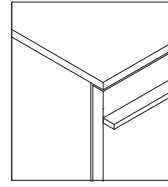

Cromo, laccata bianca  
chrome, white lacquered  
chrome, laquée blanche  
Chrome, weiß Lackierung  
хром, белая лакировка

maniglia | handle | poignées | Griff | ручка  
M801

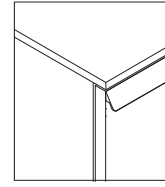

Cromo  
chrome  
chrome  
Chrome  
хром

finiture | finishes | finitions | Oberflächen | отделки

frontali, fianchi, top | fronts, sides, tops, | façades, côtés, plans | Fronten, Seiten, Platten | фасады, боковые стенки, столешницы  
laccati opachi e lucidi | matt and glossy lacquers | laques mates et brillantes | Matt- und Glanzlacken | матовые - глянцевые лакировки  
vetro, vetro acidato | glass, etched glass | verre, verre gravé | Glas, Geätztes Glas | стекло, вытравленное стекло



essenze opache | matt veneers | mates essences | Matt Holze | матовые шпоны



nobilitato | faced panels | mélamine | melaminbeschichtete Spanplatten | меламин

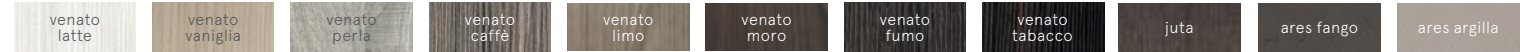

top | tops | plans | Platten | столешницы

sintetici | compounds | synthétiques | Kunststoff | соединений

Gres Laminam

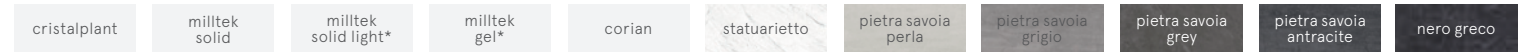

\*opachi e lucidi | matt and glossy | mates et brillantes | Matt und glänzend | матовые - глянцевые

marmi opachi | matt marbles | marbres mates | Matt Marmor | матовые мраморы

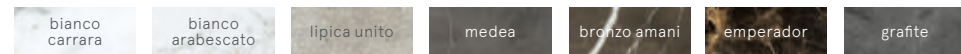

sistema | system | système | System | система

H 24 cm P 51 cm | H 9 1/2" D 20 1/8"

a. cassetto | drawer | tiroir | Schublade | ящик

b. vano a giorno | open element | élément à jour | offenes Fach | открытый элемент

H 36 cm P 51 cm | H 14 1/8" D 20 1/8"

a. cassetto | drawer | tiroir | Schublade | ящик

b. vano a giorno | open element | élément à jour | offenes Fach | открытый элемент

H 48 cm P 51 cm | H 18 7/8" D 20 1/8"

a. 2 cassetti | 2 drawers | 2 tiroirs | 2 Schubladen | 2 ящика

b. 2 ante | 2 doors | 2 portes | 2 Türen | 2 дверки

c. anta, ripiano | door, inner shelf | porte, étagère interne | Türen, Ablage | дверка, полка

d. vano a giorno, ripiano | open element, inner shelf | élément à jour, étagère interne | offenes Fach, Ablage | открытый элемент, полка

e. vano portasciugamano | open vanity | élément à jour avec porte-serviette | Handtuchfach | открытый элемент прав с полотенцедержателем

H 24 cm | 9 1/2"

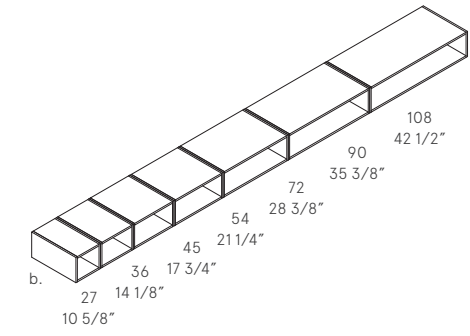
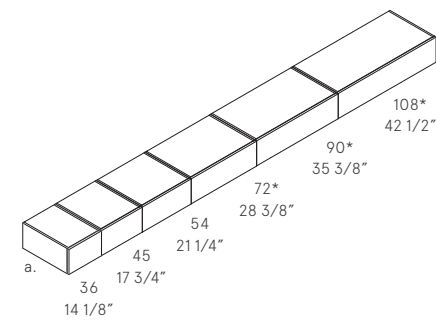

H 36 cm | 14 1/8"

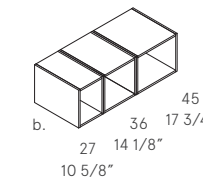
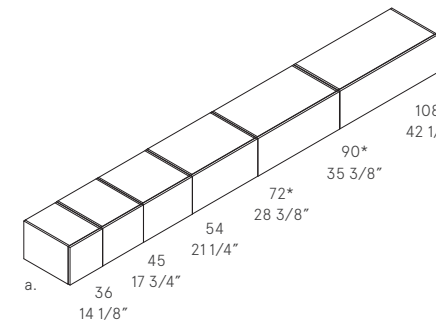

H 48 cm | 18 7/8"

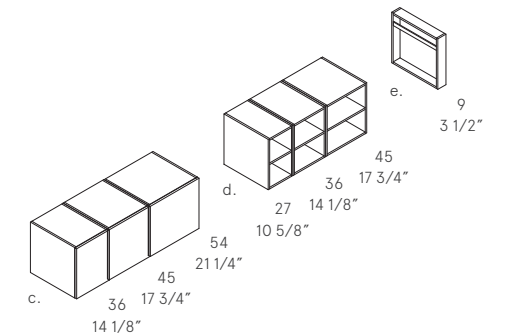
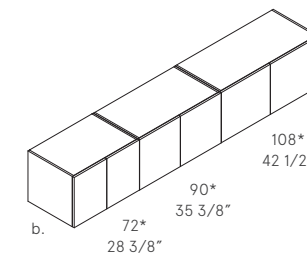
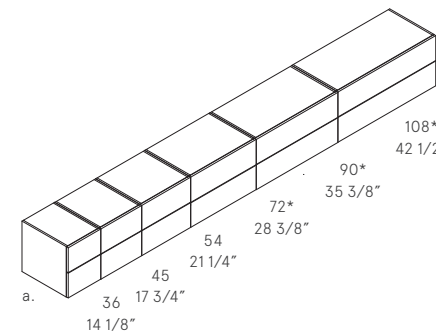

\* base lavabo | basin unit | meubles bas sous vasque | Waschbeckenunterschrank | тумбы для раковины



a. laccati opachi | matt lacquered | laques mates | Matt Lackierung | матовые лакировки  
 b. laccati lucidi spazzolati | high glossy lacquered | laques brillantes brossées | gebürstete glänzende Lackierung | брашированные глянцевые лакировки  
 c. laccati lucidi | glossy lacquered | laques brillantes | glänzende Lackierung | глянцевые лакировки

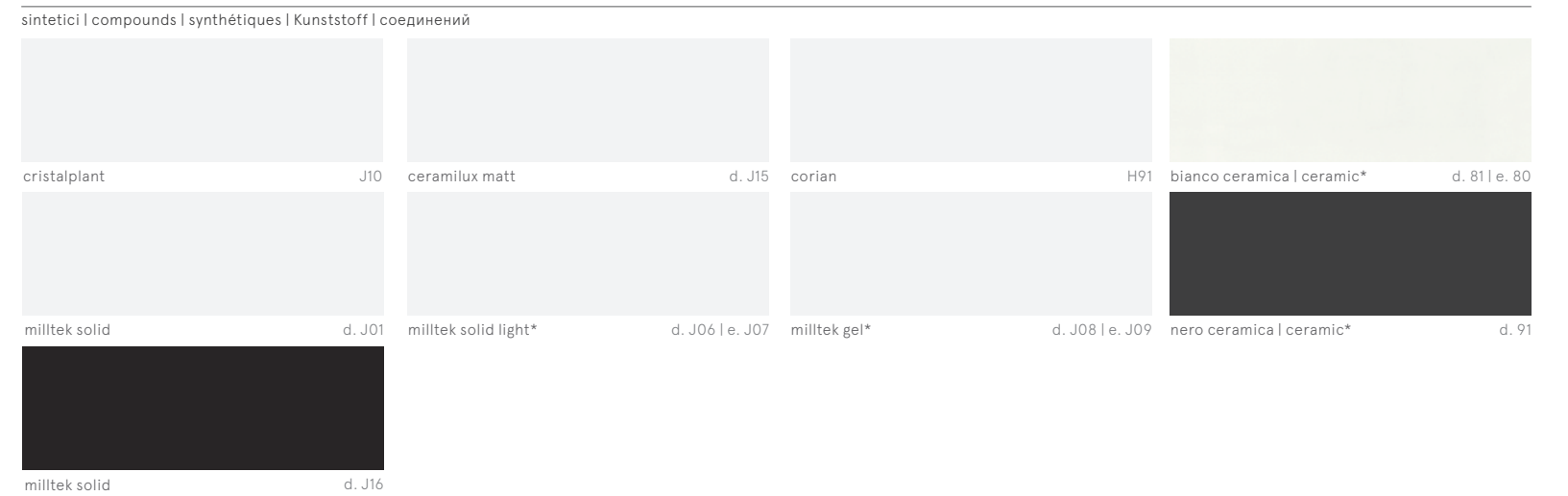
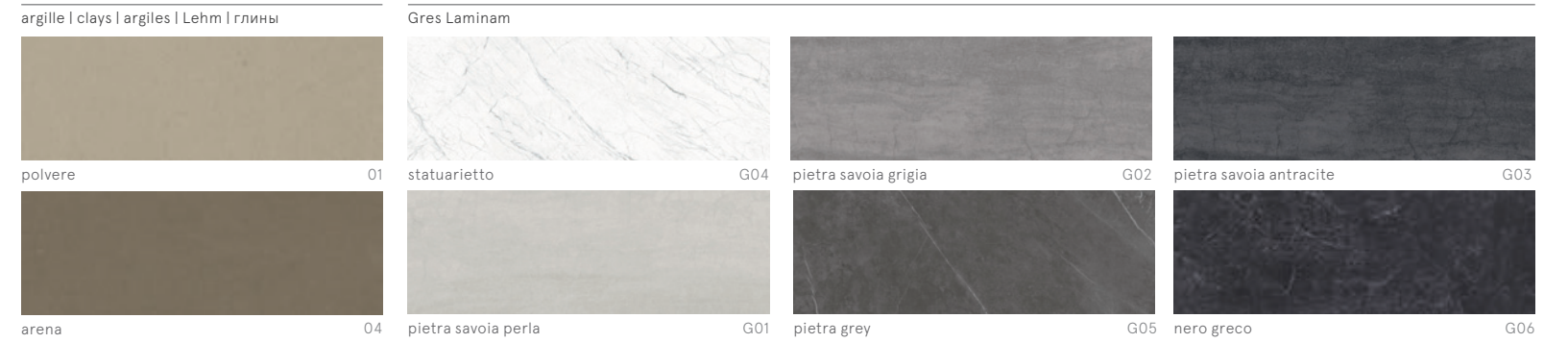
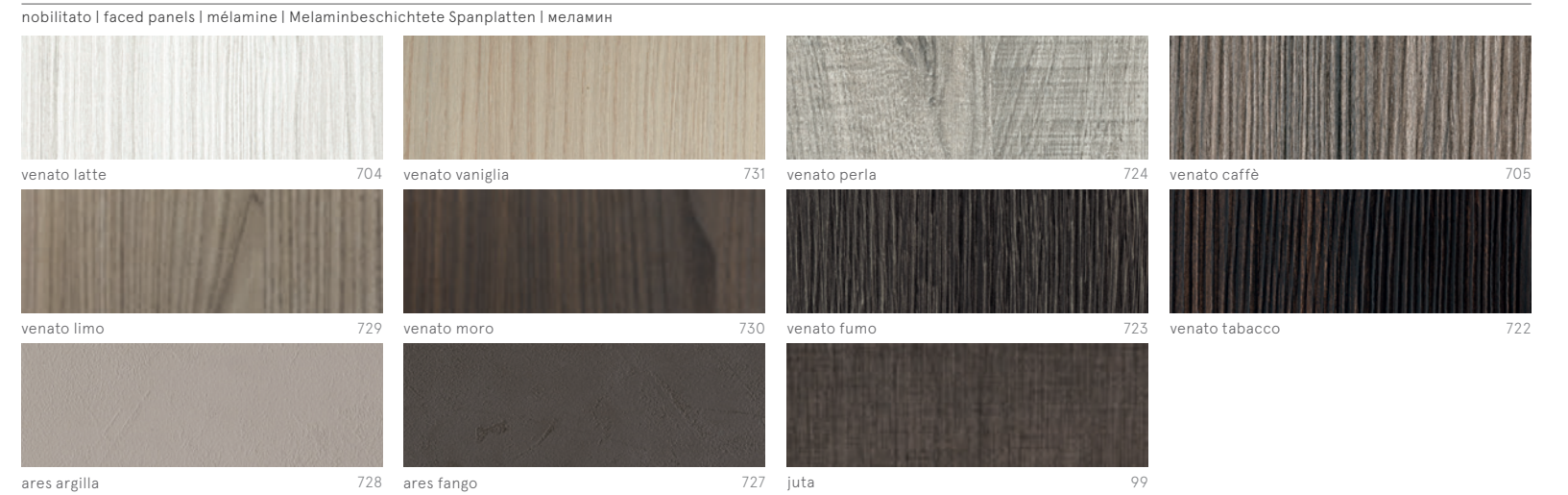
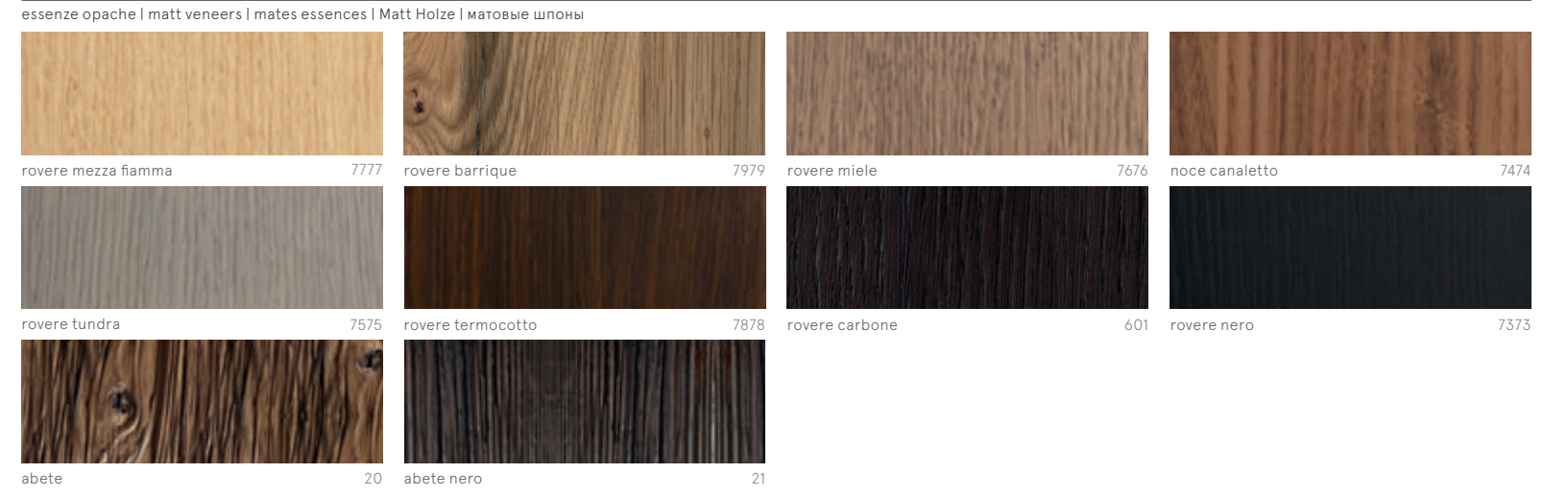
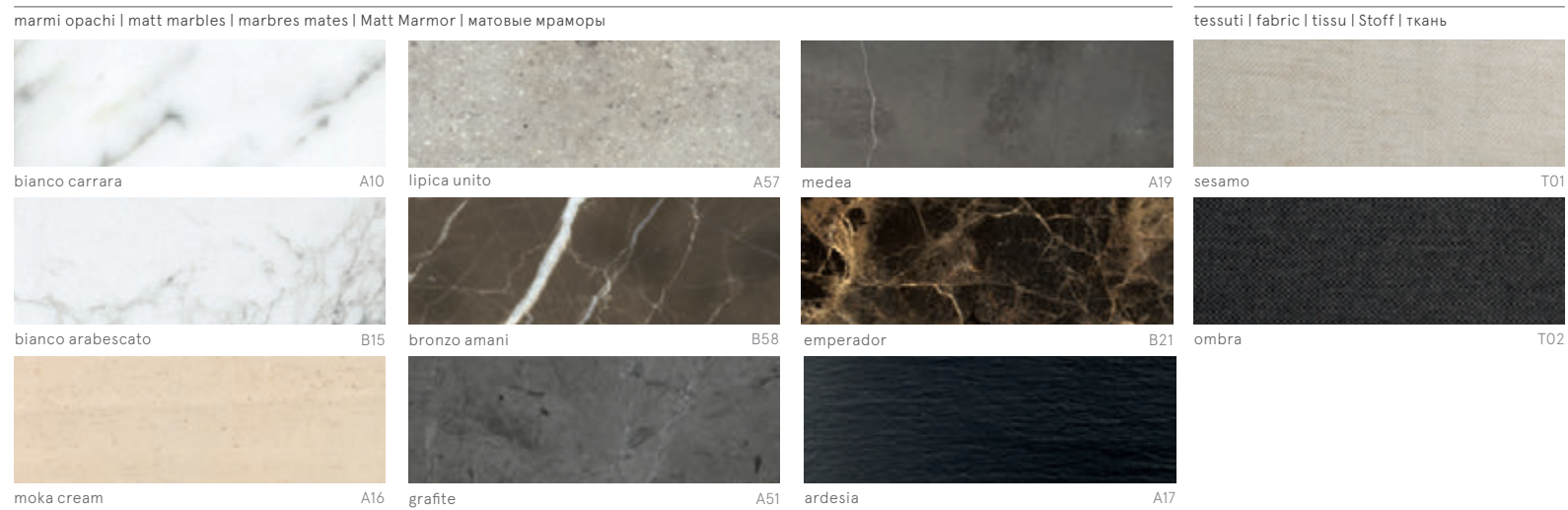

\*d. opachi | matt | mates | Matt | матовые - e. lucidi | glossy | brillantes | glänzend | глянцевые

art direction  
Paolo Mojoli

graphic design  
Juma

photos  
Federico Cedrone  
ContrattiCompany  
p 74, 75, 88, 89, 114, 115, 116, 117, 131, 132, 133, 135,  
136, 137, 138, 139, 140, 141, 142, 143, 144, 145, 204,  
205, 210, 211, 212, 213, 224, 225, 238, 239, 241, 242,  
243, 244, 245, 247, 248, 249, 252, 253, 266, 267  
Jessica Soffiati  
p 54, 58, 59, 60  
José Javier Serrano  
p 188, 192, 193, 196, 197

styling  
Martina Bianchi  
Juma  
Stefania Vasques Studio

photo studio, set assistant  
Ottonove

rendering  
Nerokubo

prepress  
Luce Group

edition  
March 2019

thanks to

Amini carpets  
Auerberg  
Bcxsy  
Bolzan  
Brollo  
Bullfrog  
Byredo  
By Lassen  
C&C Milano  
Ceratina  
Cinelli  
Colombo Design  
Couse de fil Blanc  
Cuore Di Lino  
Davide Aquini  
Dep Design Store

Edizioni Design  
Emil  
Exit  
Flos  
FontanaArte  
Gabel  
Iittala  
Incipit lab  
Ingrid Hulskamp  
Kristina Dam  
L:a Bruket  
La casa di Babette  
Le Labo  
Libeco  
Living Divani  
Madame Gioia

Nahoor  
Nasomatto  
Once Milano  
Oscar Maschera  
Raw  
Restart Milano  
Rimadesio  
Roberta Licini  
Scandola Marmi  
Shuj  
Skultuna  
Society Limonta  
Suede  
Tenoha Milano  
Toscanini  
Womo

Milldue spa si riserva il diritto di apportare modifiche migliorative al prodotto in qualsiasi momento e senza preavviso. I campioni dei materiali sono a carattere puramente indicativo. Milldue reserves the right to apply improving changes to the products at any time without prior notice. The samples are purely indicative. Milldue se réserve le droit d'apporter modifications pour l'amélioration du produit, à n'importe quel moment et sans préavis. Les échantillons sont à caractère purement indicatif. Milldue spa behält sich das Recht vor, zweckmäßige verbessernde Änderungen der Produkte ohne Voranmeldung vorzunehmen. Die Muster sind unverbindlich. Milldue оставляет за собой право в любой момент и без предупреждения усовершенствовать характеристики своих изделий. Образцы имеют исключительно ориентировочное значение.



noorth

marchio registrato  
registred trademark  
marque déposée  
eingetragene Marke  
заводская марка

milldue

milldue spa © 2013 All rights reserved

MILLDUE SPA  
sede legale: Via Balegante 7 – 31039 Riese Pio X – Treviso – Italy  
sede operativa: Via dell'Economia 6 – 31033 Castelfranco Veneto – Treviso – Italy  
P. I. 00544260268 – tel +39 0423 756611 – fax +39 0423 756699  
www.milldue.com – milldue@milldue.it



